

TSEV0108L39 Thermopile Sensor Module



- Contact less Temperature Measurement
- 8 Measurement Pixels
- Wide Supply Voltage Range
- Digital Interface Bus (SPI)

DESCRIPTION

TSEV0108L39 is a contact-less temperature measuring system for OEM use based on the detection of infrared radiation.

TSEV0108L39 is equipped with an infrared sensor (Thermopile) in front. In this version a Thermopile Array, **including 8 pixels**, is used. It has to be pointed at the target object

The basic working principle is:

- Detection of infrared radiation with a Thermopile sensor
- Determination of sensor temperature using a thermistor
- Calculation of ambient and object temperature using a processing unit

Providing the temperatures at digital output bus (SPI like Interface)

FEATURES

-20°C – +120°C Measurement Range
4V – 16V Supply Voltage Range
Up to 2°C Accuracy

APPLICATIONS

Contact less Temperature Measurement
Microwave Oven
Climate Control

TSEV0108L39 Thermopile Sensor Module

ABSOLUTE MAXIMUM RATINGS

Absolute maximum ratings are limiting values of permitted operation and should never be exceeded under the worst possible conditions either initially or consequently. If exceeded by even the smallest amount, instantaneous catastrophic failure can occur. And even if the device continues to operate satisfactorily, its life may be considerably shortened.

Parameter	Symbol	Conditions	Min	Typ	Max	Unit
Supply Voltage	V_{cc}	Measured versus GND	-0.3		16	V
Operating Temperature	T_{op}		-10		+85	°C
Storage Temperature	T_{stor}		-30		+85	°C
Humidity	Hum_L	-30°C - +50°C			85	%
Humidity	Hum_H	+50°C - +85°C			50	%

SENSOR CHARACTERISTICS

If not otherwise noted, 25°C ambient temperature, 5V supply voltage were applied.

Parameter	Symbol	Conditions	Min	Typ	Max	Unit
Total Field of View	T_{FOV}	Over all 8 Pixels		40		°
Individual Field of View	P_{FOV}	Field of View of one Pixel		3.5		°
Focal length	f			3.9	mm	

OPERATING CONDITIONS

Parameter	Symbol	Conditions	Min	Typ	Max	Unit
Supply voltage	V_{cc}	Measured versus GND	4	5	6	V
Supply Current	I	Full ambient temp. range, no output load		10	15	mA
Humidity	Hum_L	-30°C - +50°C			85	%
Humidity	Hum_H	+50°C - +85°C			50	%

INTERFACE CHARACTERISTICS

Parameter	Symbol	Conditions	Min	Typ	Max	Unit
Clock Rate (SPI)	F_{SPI}			100		kHz
Data Output Rate (New Measurement Data of all 8 Pixels available)	F_{out}			1		Hz

OPERATIONAL CHARACTERISTICS

Parameter	Symbol	Conditions	Min	Typ	Max	Unit
Object Temperature Range	T_{obj}		-20		+120	°C
Ambient Temperature Range	T_{amb}		0		+85	°C
Resolution	Res				0.1	°C
Standard Start-Up Time	t_{Start}	Time from turning on supply to first measurement		3	5	s
Accuracy tolerance when $T_{ambient} = 25°C \pm 5°C$	ΔT	-5°C < T_{object} < +5°C		$\pm 2^{1)}$		°C
		Outside above range		$\pm 4^{1)}$		°C

¹⁾ Valid for a distance of 100mm and black body size of 150mm x 150mm.

TSEV0108L39 Thermopile Sensor Module

MECHANICAL DIMENSIONS

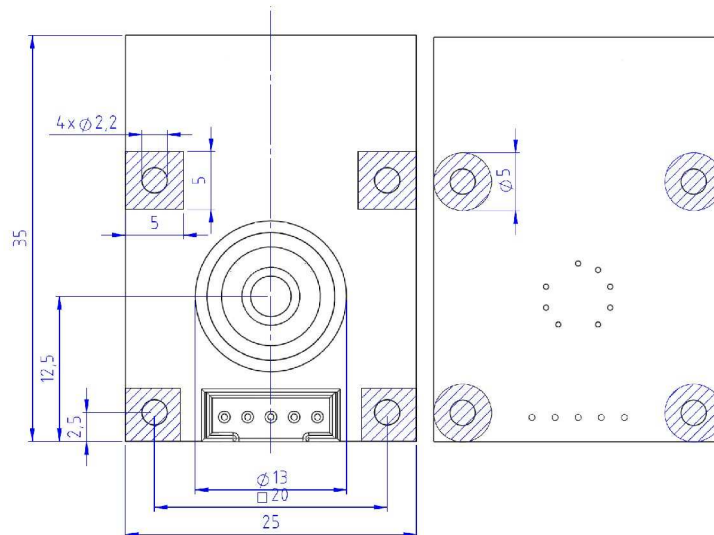

Only use hatched areas for mechanical assembly (screws, nuts, etc).

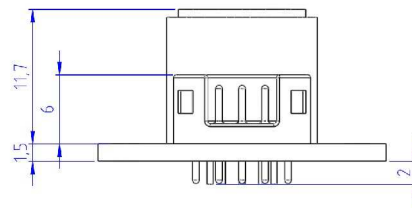

TERMINALS

Connector: JST B5B-PH-K-S(LF)(SN)

Pin	Name	Description	Type
1	GND	Supply Ground	Supply
2	MISO	Data Out	Output
3	MOSI	Data In	Input
4	CLK	Clock	Input
5	VDD	Supply Voltage	Supply

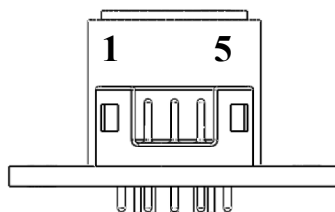

TSEV0108L39 Thermopile Sensor Module

BLOCK DIAGRAM

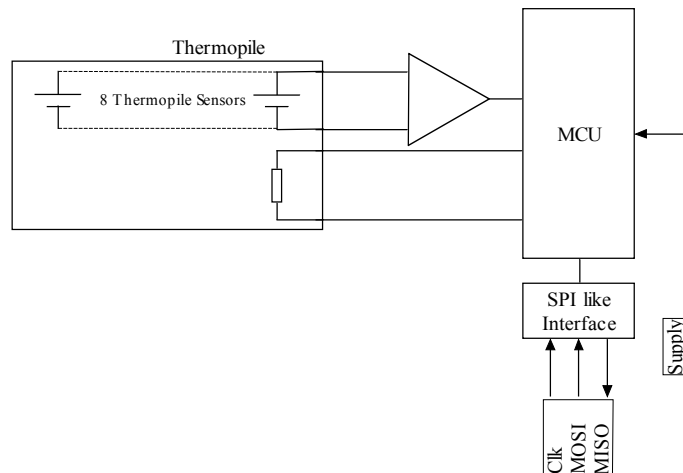

FIELD OF VIEW

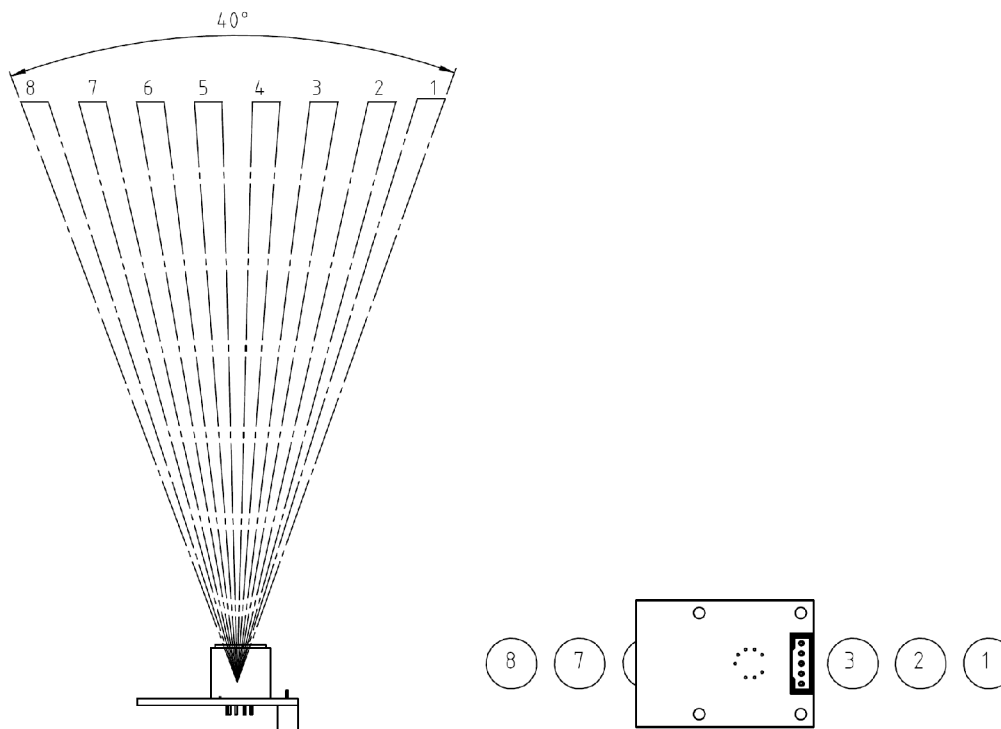

ANGLE OF PIXELS

1	2	3	4	5	6	7	8
19,03	13,84	8,41	2,82	-2,82	-8,41	-13,84	-19,03

TSEV0108L39 Thermopile Sensor Module

FUNCTION

SPI INTERFACE

PHYSICAL INTERFACE PARAMETERS

Parameter	Symbol	Conditions	Min	Typ	Max	Unit
Baudrate	FSPI		10		200	kHz
Data Bits				8		
Edge				Rising		
Chip Select				No		
Input Voltage Low					0.8	V
Input Voltage High			2.8		3.6	V
Output Current High		@ 2.8V	1			mA
Output Current Low		@ 0.8V	1			mA

SPI CONNECTION

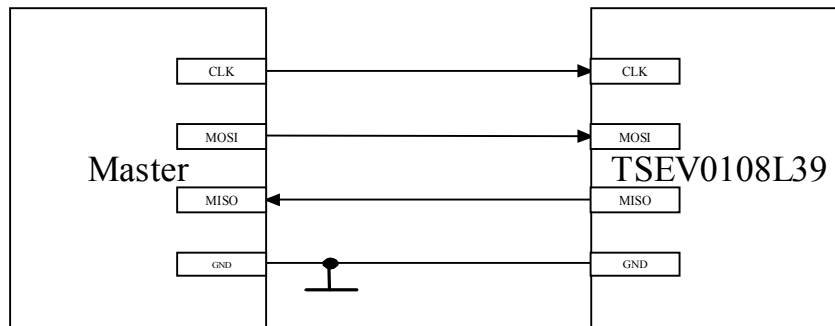

SPI SIGNAL TIMING DESCRIPTION

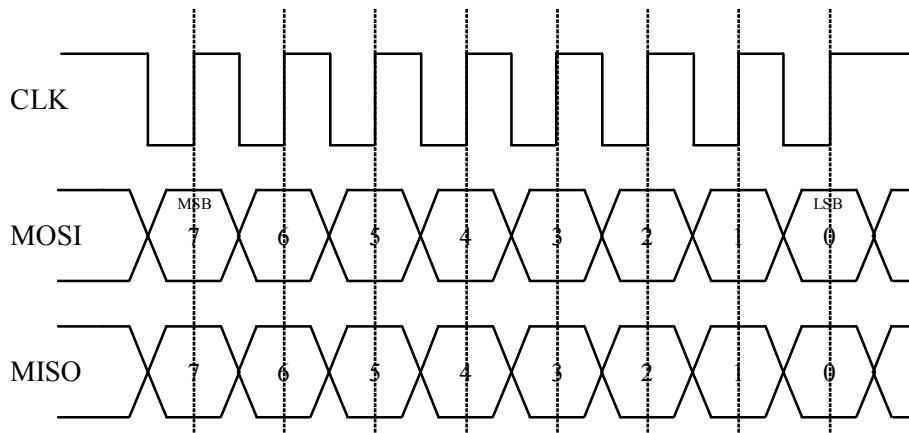

MOSI = Master Out → Slave In
MISO = Master In ← Slave Out

TSEV0108L39 Thermopile Sensor Module

INTERNAL RESET

The internal SPI status is reset to idle state if one of the following conditions occur:

- 100ms without receiving data
- Reset due to cycling of supply voltage

FILTER CIRCUITRY

Capacitors are added to the following lines in to reduce noise/spikes in order to provide stable SPI transmission even in EMC affected environment:

- CLK
- MOSI

A **10nF capacitor** is added parallel to ground potential.

SPI SIGNAL SEQUENCE

Reading Temperature of Pixel 1

Nr.	MOSI	MISO	Direction	Description
1	0xA1	---	M → S	Sending Command (See Command Reference)
Wait at least 150us to arrange temperature data				
2	0xFF	0xFF	M ← S	Receiving High Byte (Send 0xFF while receiving)
Wait at least 150us to arrange temperature data				
3	0xFF	0xFF	M ← S	Receiving Low Byte (Send 0xFF while receiving)

EXAMPLE FOR 5V SPI INTERFACE LINE

The sensor can not be connected directly to a SPI interface with 5V levels. Therefore the following circuitry is suggested. The Baudrate should be limited to 20kHz.

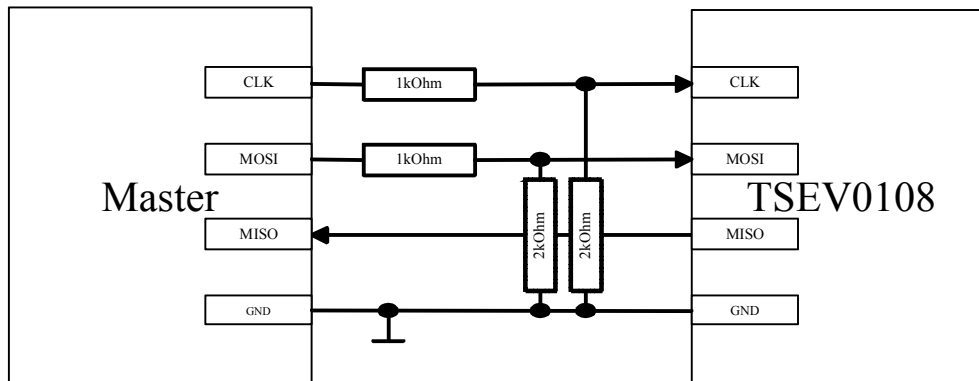

TSEV0108L39 Thermopile Sensor Module

AMBIENT AND OBJECT MEASUREMENT

Please refer following table for SPI commands to read object temperature and ambient temperature. Both values are transmitted in tenth of degrees.

All temperature read outs are to be interpreted as twos complement.

Com	Description	Reply	Bytes
0xA0	Sensor Temperature	Sensor temperature in hundredth of degrees Celsius	2
0xA1	Temperature Pixel 1	Temp. at pixel position 1 in tenth of degree Celsius	2
0xA2	Temperature Pixel 2	Temp. at pixel position 2 in tenth of degree Celsius	2
0xA3	Temperature Pixel 3	Temp. at pixel position 3 in tenth of degree Celsius	2
0xA4	Temperature Pixel 4	Temp. at pixel position 4 in tenth of degree Celsius	2
0xA5	Temperature Pixel 5	Temp. at pixel position 5 in tenth of degree Celsius	2
0xA6	Temperature Pixel 6	Temp. at pixel position 6 in tenth of degree Celsius	2
0xA7	Temperature Pixel 7	Temp. at pixel position 7 in tenth of degree Celsius	2
0xA8	Temperature Pixel 8	Temp. at pixel position 8 in tenth of degree Celsius	2

EXAMPLE OF TEMPERATURE CALCULATION

For reading object temperature of pixel 3 send: 0xA3

Return values i.e.:

$$\text{Byte}(0) = 0x02$$

$$\text{Byte}(1) = 0xB0$$

$$\text{Temperature } T_{\text{obj}} = (256 * \text{Byte}(0) + \text{Byte}(1)) / 10 = (256 * 2 + 11) / 10 = \underline{52.3^{\circ}\text{C}}$$

OUT OF TEMPERATURE RANGE INDICATION

Com	Description	Reply	Bytes
0xA0	Sensor Temperature < 0°C	0x8001	2
0xA0	Sensor Temperature > 85°C	0x8002	2
0xA1 – 0xA8	Pixel Temperature < -20°C	0x8003	2
0xA1 – 0xA8	Pixel Temperature > +120°C	0x8004	2

ORDER INFORMATION

Please order this product using following:

Part Number	Part Description
G-TPMO-014	TSEV0108L39

TSEV0108L39 Thermopile Sensor Module

EMC

Due to the use of these modules for OEM application no CE declaration is done.

Especially line coupled disturbances like surge, burst, HF etc. cannot be removed by the module due to the small board area and low price feature. There is no protection circuit against reverse polarity or over voltage implemented.

The module will be designed using capacitors for blocking and ground plane areas in order to prevent wireless coupled disturbances as good as possible.

DEFINITIONS AND DISCLAIMERS

- Application information – Applications that are described herein for any of these products are for illustrative purpose only. MEAS Deutschland GmbH makes no representation or warranty that such applications will be suitable for the specified use without further testing or modification.
- Life support applications – These products are not designed for use in life support appliances, devices, or systems where malfunctions of these products can reasonably be expected to result in personal injury.
MEAS Deutschland GmbH customers using or selling this product for use in such applications do so at their own risk and agree to fully indemnify MEAS Deutschland GmbH for any damages resulting from such improper use or sale.

TECHNICAL CONTACT INFORMATION

NORTH AMERICA	EUROPE	ASIA
Measurement Specialties, Inc. 1000 Lucas Way Hampton, VA 23666 United States Phone: +1-800-745-8008 Fax: +1-757-766-4297 Email: sales@meas-spec.com Web: www.meas-spec.com	MEAS Deutschland GmbH Hauert 13 D-44227 Dortmund Germany Phone: +49-(0)231-9740-0 Fax: +49-(0)231-9740-20 Email: info.de@meas-spec.com Web: www.meas-spec.com	Measurement Specialties China Ltd. No. 26, Langshan Road High-tech Park (North) Nanshan District, Shenzhen 518057 China Phone: +86-755-33305088 Fax: +86-755-33305099 Email: info.cn@meas-spec.com Web: www.meas-spec.com

The information in this sheet has been carefully reviewed and is believed to be accurate; however, no responsibility is assumed for inaccuracies. Furthermore, this information does not convey to the purchaser of such devices any license under the patent rights to the manufacturer. Measurement Specialties, Inc. reserves the right to make changes without further notice to any product herein. Measurement Specialties, Inc. makes no warranty, representation or guarantee regarding the suitability of its product for any particular purpose, nor does Measurement Specialties, Inc. assume any liability arising out of the application or use of any product or circuit and specifically disclaims any and all liability, including without limitation consequential or incidental damages. Typical parameters can and do vary in different applications. All operating parameters must be validated for each customer application by customer's technical experts. Measurement Specialties, Inc. does not convey any license under its patent rights nor the rights of others.