

Model TS305-10C50 Thermopile Sensor



- Thermopile IR-Sensor
- For Contactless Temperature Measurement
- Single Element
- High Signal
- Flat Filter
- Accurate Reference Sensor



DESCRIPTION

Thermopiles are mainly used for contactless temperature measurement in many applications. Their function is to transfer the heat radiation emitted from the objects into a voltage output.

FEATURES

High Signal
Accurate NTC Reference Sensor
5.0µm Long Wave Pass Filter

APPLICATIONS

Industrial Pyrometers
Climate Control
Medical

ABSOLUTE MAXIMUM RATINGS

Parameter	Symbol	Min	Typical	Max	Unit	Description
Storage Temperature	T _s	-20	+20	+85	°C	permanent
Storage Temperature	T _s	-20	+20	+100	°C	non permanent

Model TS305-10C50 Thermopile Sensor

PERFORMANCE SPECS

Parameter	Symbol	Value	Unit	Condition
Operating Ambient Temperature	T_{Amb}	-20 to +85	°C	permanent
Operating Ambient Temperature	T_{Amb}	-20 to +100	°C	non permanent
Package		TO-5		
Absorber Area	A	0.8×0.8	mm ²	
Thermopile Resistance	R_{TP}	70 ± 30	k Ω	$T_{Amb} = +25^{\circ}\text{C}$
Temperature Coefficient of Thermopile Resistance	TCR_{TP}	-0.06 ± 0.04	%/K	$T_{Amb} = +25^{\circ}\text{C}$ to $+75^{\circ}\text{C}$
Voltage Response	V_{TP}	6.5 ± 1.9	mV	$T_{Amb} = +25^{\circ}\text{C}$, $T_{Obj} = +100^{\circ}\text{C}$, DC, totally filled field of view
Temperature Coefficient of Voltage Response	TCV_{TP}	-0.45 ± 0.08	%/K	$T_{Amb} = +25^{\circ}\text{C}$ to $+75^{\circ}\text{C}$
Noise Equivalent Voltage	NEV	45	nV/Hz ^{1/2}	$T_{Amb} = +25^{\circ}\text{C}$
Rise Time	τ_{63}	12 ± 5	ms	
Ambient Temperature Sensor		NTC		
Ambient Temperature Sensor Resistance	R_{NTC}	100 ± 5	k Ω	$T_{Amb} = +25^{\circ}\text{C}$
Beta Value of NTC	β -Value	$3955 \pm 0.3\%$	K	$T_{Amb} = 0^{\circ}\text{C}$ to $+50^{\circ}\text{C}$

TYPICAL PERFORMANCE CURVES

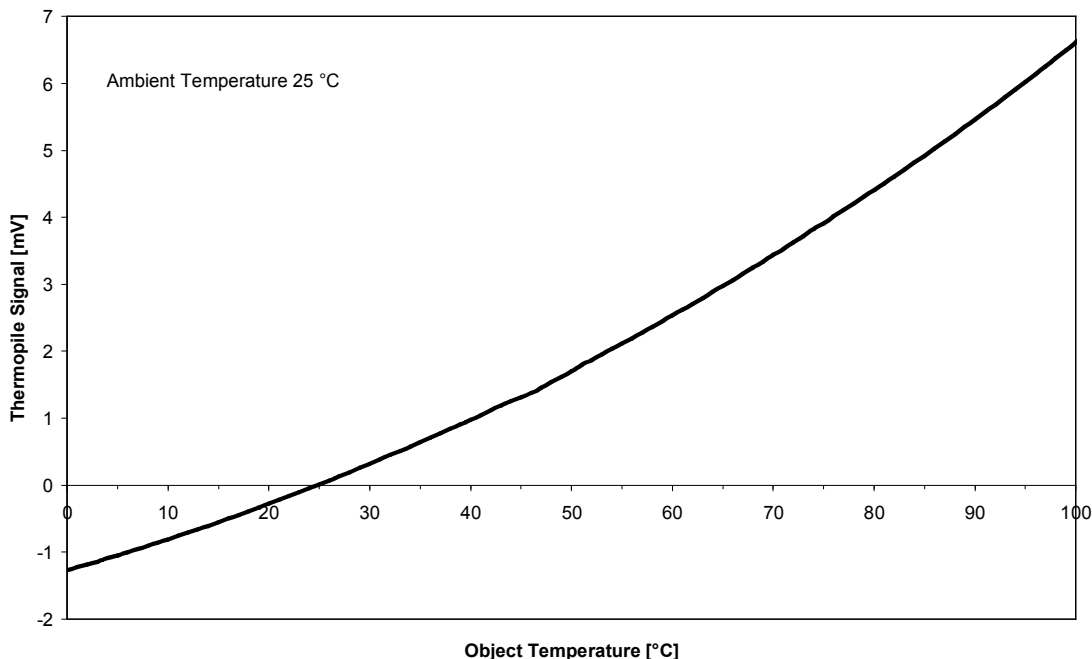

Figure 1: Thermopile signal versus object temperature at 25°C ambient temperature

Model TS305-10C50 Thermopile Sensor

OPTICAL CHARACTERISTICS

Parameter	Symbol	Value	Unit	Description
Field of View	FOV	80	deg	at 50% of maximum signal

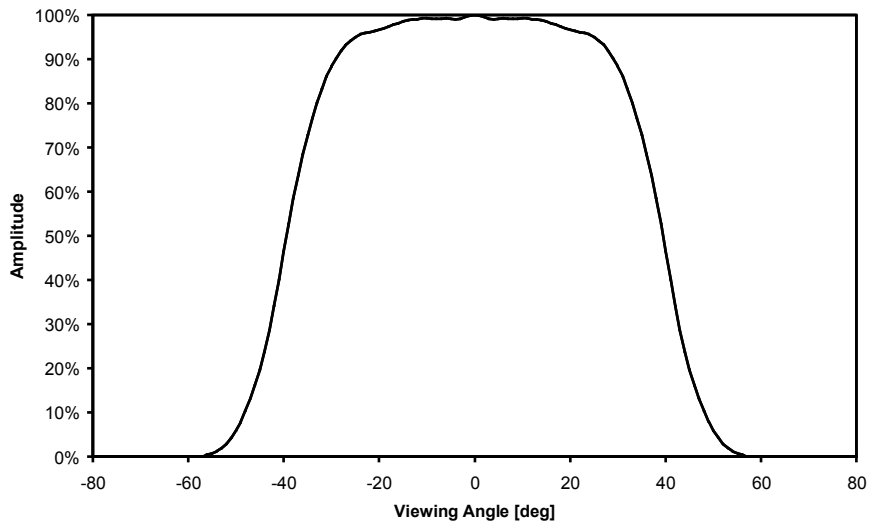

Figure 2: Field of View Curve

FILTER CHARACTERISTICS

Parameter	Symbol	Value	Unit	Description
Transmission Range	LWP	≥ 5.0	μm	Long Wave Pass

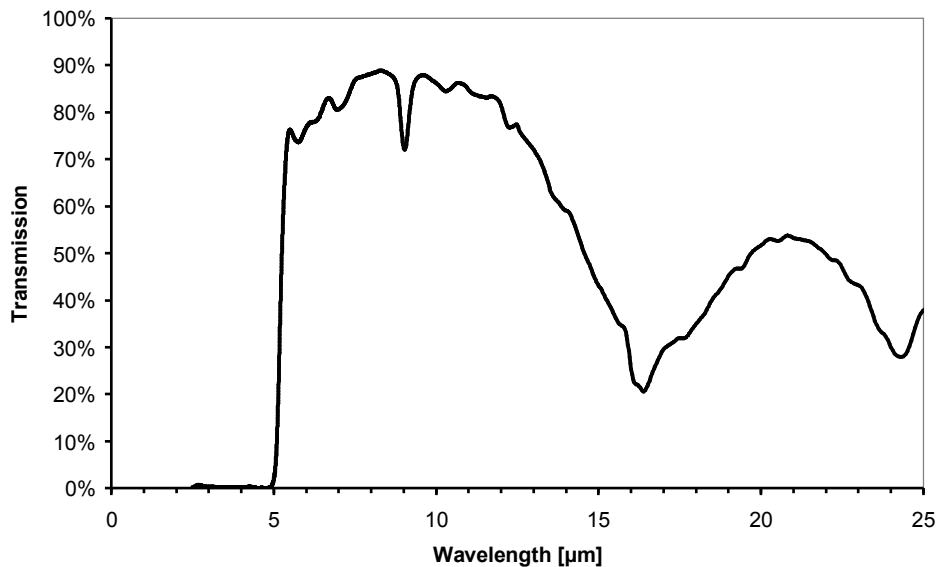

Figure 3: Filter transmission curve

Model TS305-10C50 Thermopile Sensor

ELECTRICAL CONNECTIONS

Pin	Symbol
1	TP +
2	NTC
3	TP -
4	GND

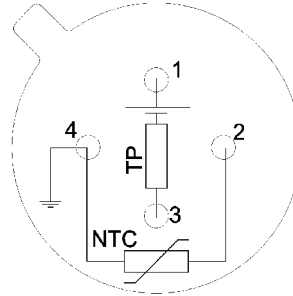

Figure 4: Electrical connections - bottom view of thermopile

MECHANICAL DIMENSIONS

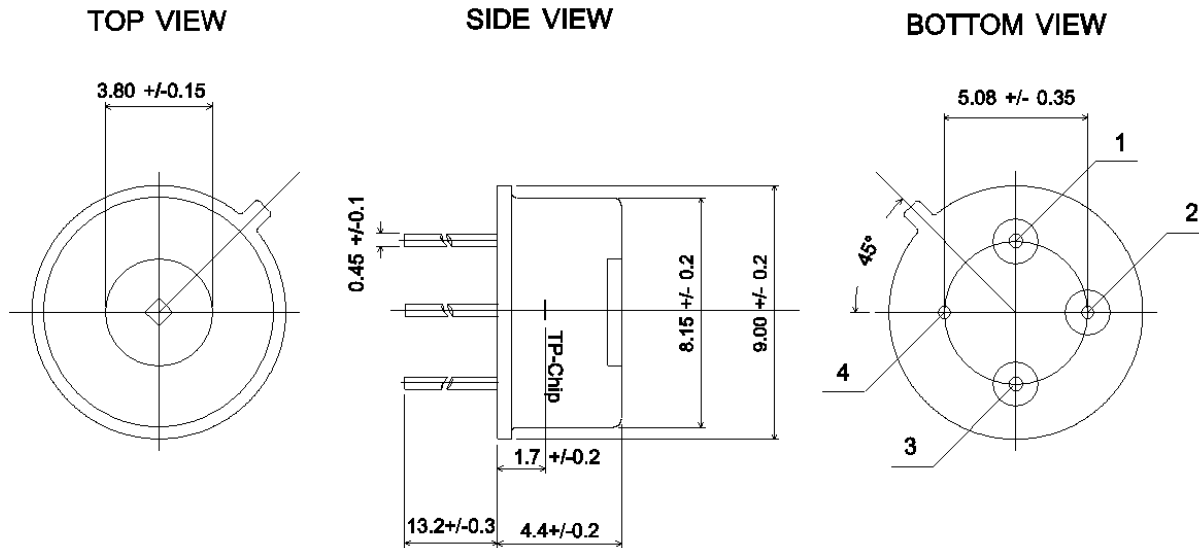

Figure 5: Mechanical dimensions of thermopile

Model TS305-10C50 Thermopile Sensor

ORDERING INFORMATION

Part Description TS305-10C50

Part No. G-TPCO-023

TECHNICAL CONTACT INFORMATION

North America	Europe	Asia
<p>Measurement Specialties, Inc.</p> <p>1000 Lucas Way Hampton, VA 23666</p> <p>Tel: 1-800-745-8008 Fax: 1-757-766-4297 Email: sales@meas-spec.com</p>	<p>MEAS Deutschland GmbH</p> <p>Hauert 13, D-44227 Dortmund, Germany</p> <p>Phone: +49-(0)231-9740-0 Fax: +49-(0)231-9740-20 Email: info.de@meas-spec.com</p>	<p>Measurement Specialties China Ltd.</p> <p>No. 26, Langshan Road, Shenzhen High-tech Park (North) Nanshan District, Shenzhen, China 518057</p> <p>Phone: +86-755-33305088 Fax: +86-755-33305099 Email: sales.china@meas-spec.com</p>

The information in this sheet has been carefully reviewed and is believed to be accurate; however, no responsibility is assumed for inaccuracies. Furthermore, this information does not convey to the purchaser of such devices any license under the patent rights to the manufacturer. Measurement Specialties, Inc. reserves the right to make changes without further notice to any product herein. Measurement Specialties, Inc. makes no warranty, representation or guarantee regarding the suitability of its product for any particular purpose, nor does Measurement Specialties, Inc. assume any liability arising out of the application or use of any product or circuit and specifically disclaims any and all liability, including without limitation consequential or incidental damages. Typical parameters can and do vary in different applications. All operating parameters must be validated for each customer application by customer's technical experts. Measurement Specialties, Inc. does not convey any license under its patent rights nor the rights of others.