

Model 7104A Accelerometer



IEPE Accelerometer
Wide Bandwidth to >10kHz
10-32 Side Connector
Stud Mount, Hermetic



The Model 7104A is a high performance IEPE accelerometer available in $\pm 50g$ to $\pm 1000g$ dynamic ranges. The stud mounted accelerometer features a welded hermetic construction with a side mount connector. The model 7104A incorporates stable piezo-ceramic crystals in annular shear mode which provide a flat frequency response up to >10kHz. The standard operating temperature range extends from -55°C to $+125^{\circ}\text{C}$.

FEATURES

- $\pm 50g$ to $\pm 1000g$ Dynamic Range
- Wide bandwidth up to >10kHz
- Welded Construction
- Hermetically Sealed
- Annular Shear Mode
- Stable Temperature Response
- TEDS Option

APPLICATIONS

- Vibration & Shock Monitoring
- Laboratory Testing
- Modal Applications
- High Frequency Applications
- General Purpose Usage

dimensions

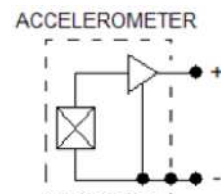
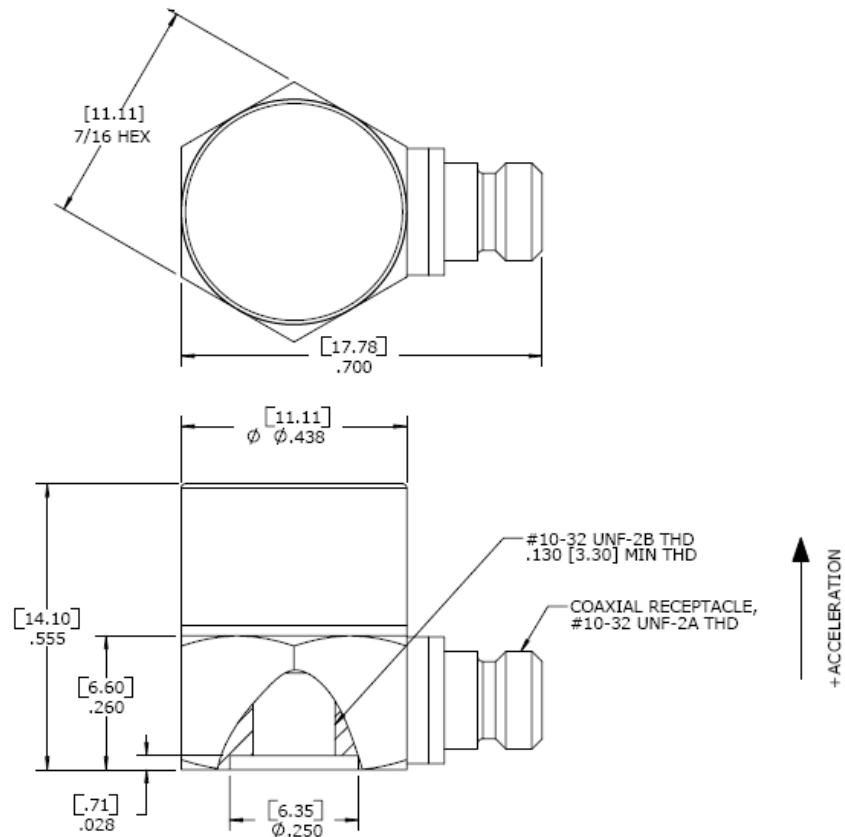

Model 7104A Accelerometer

performance specifications

All values are typical at +24°C, 100Hz and 4mA excitation unless otherwise stated. Measurement Specialties reserves the right to update and change these specifications without notice. Standard product parameters are described in PSC-1003 for Plug & Play AC Accelerometers.

Parameters					Notes
DYNAMIC					
Range (g)	±50	±100	±500	±1000	
Sensitivity (mV/g)	100	50	10	5	±10%
Frequency Response (Hz)	0.5-6000	0.5-6000	0.5-8000	0.5-8000	±5%
Frequency Response (Hz)	0.3-10000	0.3-10000	0.3-10000	0.3-10000	±1dB
Natural Frequency (Hz)	>50000	>50000	>50000	>50000	
Non-Linearity (%FSO)	±1	±1	±1	±1	
Transverse Sensitivity (%)	<5	<5	<5	<5	
Shock Limit (g)	5000	5000	5000	5000	
ELECTRICAL					
Compliance Voltage (Vdc)	18 to 30	18 to 30	18 to 30	18 to 30	
Excitation Current (mA) ¹	2 to 10	2 to 10	2 to 10	2 to 10	See Note 1
Bias Voltage (Vdc)	8 to 12	8 to 12	8 to 12	8 to 12	Room Temperature
Bias Voltage (Vdc)	6 to 13	6 to 13	6 to 13	6 to 13	-55 to +125°C
Output Impedance (Ω)	<100	<100	<100	<100	
Full Scale Output Voltage (V)	±5	±5	±5	±5	
Residual Noise (g RMS)	0.0004	0.0005	0.0008	0.0014	Broadband 1Hz to 10kHz
Discharge Time Constant (sec)	0.8 to 1.2				
Grounding	Case Grounded				
ENVIRONMENTAL					
Temperature Response (%)	See Typical Temperature Response Curve				
Operating Temperature (°C)	-55 to +125				
Storage Temperature (°C)	-55 to +125				
Humidity	Hermetically Sealed				
PHYSICAL					
Sensing Element	Ceramic (shear mode)				
Case Material	Stainless Steel				
Electrical Connector	10-32 Coaxial Receptacle				
Weight (grams)	8.6				
Mounting	#10-32 to #10-32 Mounting Stud (included)				
Mounting Torque	18 lb-in (2.0 N-m)				
¹ Maximum 4mA at +125°C					
Calibration supplied:	CS-FREQ-0100	NIST Traceable Amplitude Calibration from 20Hz to ±1dB Frequency Response Limit			
Supplied accessories:	AC-D02298	10-32 to 10-32 mounting stud			
Optional accessories:	310-XXX	Cable Assembly, 10-32 to 10-32 (XXX designates length in inches, 10ft standard)			
	314-XXX	Cable Assembly, 10-32 to BNC (XXX designates length in inches, 10ft standard)			
	AC-A03470	Adhesive Mounting Adaptor			
	AC-A03471	Magnetic Mounting Adaptor			
	AC-A03500	Isolated Mounting Adaptor (#10-32 to M5x0.8 thread)			

The information in this sheet has been carefully reviewed and is believed to be accurate; however, no responsibility is assumed for inaccuracies. Furthermore, this information does not convey to the purchaser of such devices any license under the patent rights to the manufacturer. Measurement Specialties, Inc. reserves the right to make changes without further notice to any product herein. Measurement Specialties, Inc. makes no warranty, representation or guarantee regarding the suitability of its product for any particular purpose, nor does Measurement Specialties, Inc. assume any liability arising out of the application or use of any product or circuit and specifically disclaims any and all liability, including without limitation consequential or incidental damages. Typical parameters can and do vary in different applications. All operating parameters must be validated for each customer application by customer's technical experts. Measurement Specialties, Inc. does not convey any license under its patent rights nor the rights of others.

Model 7104A Accelerometer

performance specifications

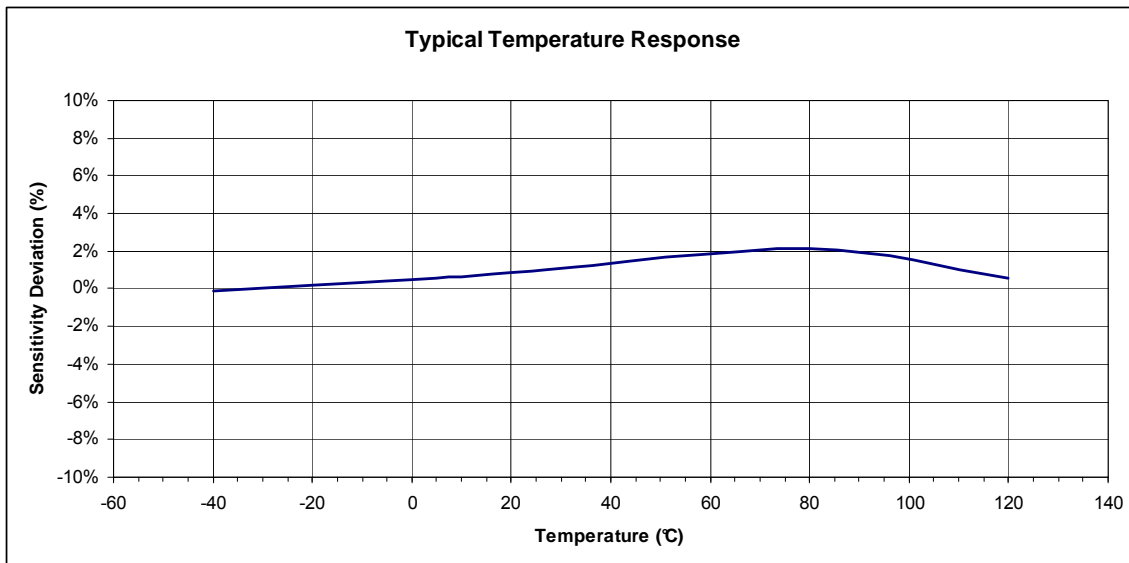
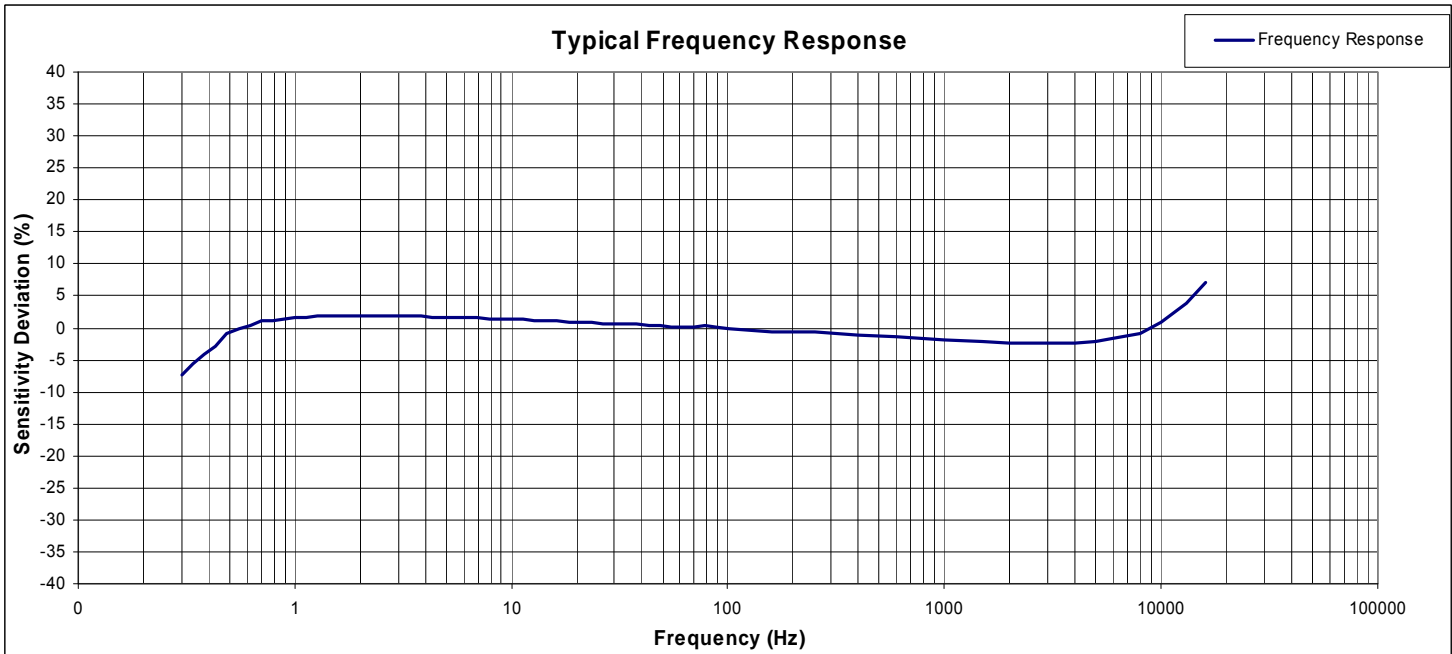

ordering info

PART NUMBERING Model Number+Range

7104AT-GGGG

I | Range (0050 is 50g)

I | TEDS compliant to IEEE 1451.4 when 'T' option is included

Example: 7104A-0050

Model 7104A, 50g