

85 Constant Voltage



- 316L SS Pressure Sensor
- Small Profile
- 0 - 100mV Output
- Absolute and Gage
- Temperature Compensated

DESCRIPTION

The 85 constant voltage is a small profile, media compatible, piezoresistive silicon pressure sensor packaged in a 316L stainless steel housing. The 85 constant voltage is offered in a weldable package or with a variety of threaded fittings such as 1/4 and 1/8NPT, 1/4BSP as well as custom process fittings.

The 85 constant voltage is designed for OEM applications where compatibility with corrosive media is required. The sensing package utilizes silicon oil to transfer pressure from the 316L stainless steel diaphragm to the sensing element. A ceramic substrate is attached to the package that contains laser-trimmed resistors for temperature compensation and offset correction.

Please refer to the 85 uncompensated and compensated datasheets for more information on different features of the 85.

FEATURES

- Weldable and Threaded Process Fittings
- -40°C to +125°C Operating Temperature Range
- Up to $\pm 0.1\%$ Pressure Non Linearity
- 1.0% Interchangeable Span (provided by gain set resistor)
- Solid State Reliability

APPLICATIONS

- Medical Instruments
- Process Control
- Fresh & Waste Water Measurements
- Partial Vacuum Gas Measurement
- Pressure Transmitters
- Tank Level Systems (RV & Industrial)

STANDARD RANGES

Range	psia	psig
0 to 5	•	•
0 to 15	•	•
0 to 30	•	•
0 to 50	•	•
0 to 100	•	•
0 to 300	•	•
0 to 500	•	•

85 Constant Voltage

PERFORMANCE SPECIFICATIONS

Supply Voltage: 10Vdc

Ambient Temperature: 25°C (unless otherwise specified)

PARAMETERS	005PSI			≥015PSI			UNITS	NOTES
	MIN	TYP	MAX	MIN	TYP	MAX		
Span	98	100	102	99	100	101	mV	
Zero Pressure Output	-2.0	0	2.0	-1.0	0	1.0	mV	1
Pressure Non Linearity	-0.20		0.20	-0.10		0.10	%Span	2
Pressure Hysteresis	-0.10	±0.02	0.10	-0.05	±0.02	0.05	%Span	
Repeatability		±0.02			±0.02		%Span	
Input Resistance	5.5K	9.0K	12.5K	5.5K	9.0K	12.5K	Ω	
Output Resistance	4.0K		6.0K	4.0K		6.0K	Ω	
Temperature Error – Span	-1.5		1.5	-1.0		1.0	%Span	3
Temperature Error – Offset	-2.5		2.5	-1.0		1.0	%Span	3
Thermal Hysteresis – Span	-0.25	±0.05	0.25	-0.25	±0.05	0.25	%Span	3
Thermal Hysteresis – Offset	-0.25	±0.05	0.25	-0.25	±0.05	0.25	%Span	3
Long Term Stability – Span		±0.10			±0.10		%Span/Year	
Long Term Stability – Offset		±0.25			±0.10		%Span/Year	
Supply Voltage		10	14		10	14	Vdc	4
Output Load Resistance	5M			5M			Ω	5
Insulation Resistance (50Vdc)	50M			50M			Ω	6
Output Noise (10Hz to 1KHz)		1.0			1.0		uV p-p	
Response Time (10% to 90%)			0.1			0.1	ms	
Pressure Overload			3X			3X	Rated	
Pressure Burst			4X			4X	Rated	7
Compensated Temperature	0		+50	-20		+85	°C	8
Operating Temperature	-20		+70	-40		+125	°C	8
Storage Temperature	-40		+125	-50		+125	°C	8
Media – Pressure Port	Liquids and Gases compatible with 316/316L Stainless Steel							
Media – Reference Port	Compatible with Silicon, Pyrex, Gold, Fluorosilicone Rubber, and 316/316L Stainless Steel							

Notes

1. Measured at vacuum for absolute (A), ambient for gage (G).
2. Best fit straight line.
3. Over the compensated temperature range with respect to 25°C.
4. Guarantees output/input ratiometricity.
5. Load resistance to reduce measurement errors due to output loading.
6. Between case and sensing element.
7. The maximum pressure that can be applied to a transducer without rupture of either the sensing element or transducer.
8. Maximum temperature range for product with standard cable and connector is -20 to +105°C.

85 Constant Voltage

DIMENSIONS

DIMENSIONS ARE IN INCHES [mm]

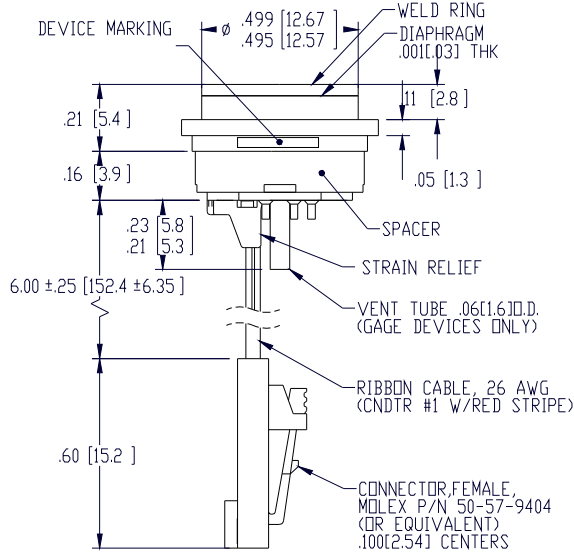

PROCESS FITTING OPTIONS

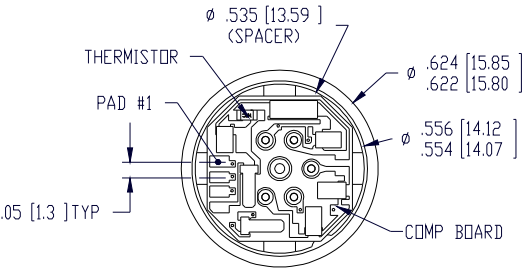
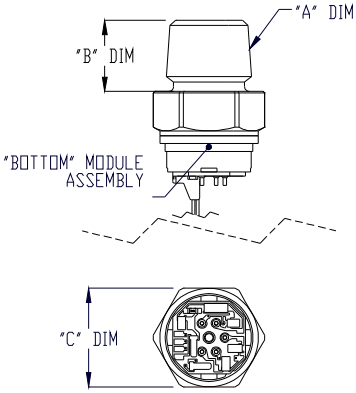

VIEW SHOWN W/O CABLE AND CONNECTOR FOR CLARITY

PAD NO	FUNCTION
1	-OUT
2	+OUT
3	-EX
4	+EX

FITTING DIMENSIONS				
FITTING TYPE	MEAS PART NO.	"A" DIM	"B" DIM	"C" DIM
1	IC-7050	1/4-18 NPT	.99[25.1]	7/8[22.2] HEX
2	IC-7049	1/8-27 NPT	.96[24.4]	7/8[22.2] HEX
3	IC-7048	7/16-20 UNF	.81[20.6]	7/8[22.2] HEX
4	IC-6754	1/4-18 NPT	.73[18.5]	5/8[15.9] HEX
5	IC-5010	1/4-19 BSP	.76[19.3]	3/4[19.0] HEX
8	IC-6800	1/8-27 NPT	.60[15.2]	5/8[15.9] HEX
9	IC-7124	1/4-19 BSP	.94[23.9]	7/8[22.2] HEX

NOTE : FTG TYPE '4' ASSEMBLY SHOWN
ALL DIMS ARE FOR REFERENCE

APPLICATION SCHEMATIC

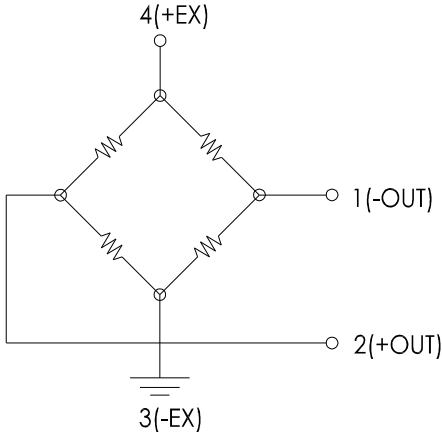

85 Constant Voltage

ORDERING INFORMATION

85CV - 050 G - 0 C T

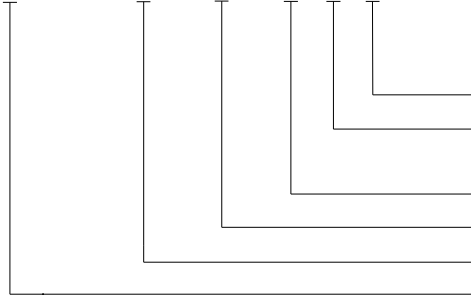

Vent (T = Tube, Blank = No Tube)
Electrical (R = Ribbon Cable,
C = Cable with connector)
Fitting Type (0 = Weldable, See Fittings)
Type (A = Absolute, G = Gage)
Pressure Range
Model

NORTH AMERICA

Measurement Specialties
45738 Northport Loop West
Fremont, CA 94538
Tel: 1-800-767-1888
Fax: 1-510-498-1578
Sales: pfg.cs.amer@meas-spec.com

EUROPE

Measurement Specialties
(Europe), Ltd.
26 Rue des Dames
78340 Les Clayes-sous-Bois, France
Tel: +33 (0) 130 79 33 00
Fax: +33 (0) 134 81 03 59
Sales: pfg.cs.emea@meas-spec.com

ASIA

Measurement Specialties
(China), Ltd.
No. 26 Langshan Road
Shenzhen High-Tech Park (North)
Nanshan District, Shenzhen 518057
China
Tel: +86 755 3330 5088
Fax: +86 755 3330 5099
Sales: pfg.cs.asia@meas-spec.com

The information in this sheet has been carefully reviewed and is believed to be accurate; however, no responsibility is assumed for inaccuracies. Furthermore, this information does not convey to the purchaser of such devices any license under the patent rights to the manufacturer. Measurement Specialties, Inc. reserves the right to make changes without further notice to any product herein. Measurement Specialties, Inc. makes no warranty, representation or guarantee regarding the suitability of its product for any particular purpose, nor does Measurement Specialties, Inc. assume any liability arising out of the application or use of any product or circuit and specifically disclaims any and all liability, including without limitation consequential or incidental damages. Typical parameters can and do vary in different applications. All operating parameters must be validated for each customer application by customer's technical experts. Measurement Specialties, Inc. does not convey any license under its patent rights nor the rights of others.