

Miniature Axial Glass Thermistor



- Glass hermetic encapsulation with high resistance to humid environments
- Wide operating temperature range
- High stability
- Fast response time
- RoHS Compliant

DESCRIPTION

The NTC Chip hermetically sealed in a miniature glass encapsulation package

FEATURES

- Hermetically sealed glass package
- High stability at elevated temperatures
- Available in $\pm 20\%$ tolerance @ +25°C
- Fast time response
- Pt/Ir lead wires suitable for welding
- Temperature range -40°C to +250°C

APPLICATIONS

- Air flow detection systems
- Blood analysis
- Liquid level sensing
- Platen Temperature sensing
- Medical Catheter devices
- Fluid flow sensing

PERFORMANCE SPECS

Parameters	Units	Value
Resistance @ +25°C	Ohms	10,000
Resistance tolerance @ +25°C	%	± 20
Beta Value 25/85	K	3499
Dissipation Constant in still air	mW/°C	0.15
Time response in still air	Second	< 1

Miniature Axial Glass Thermistor

MECHANICAL DETAILS

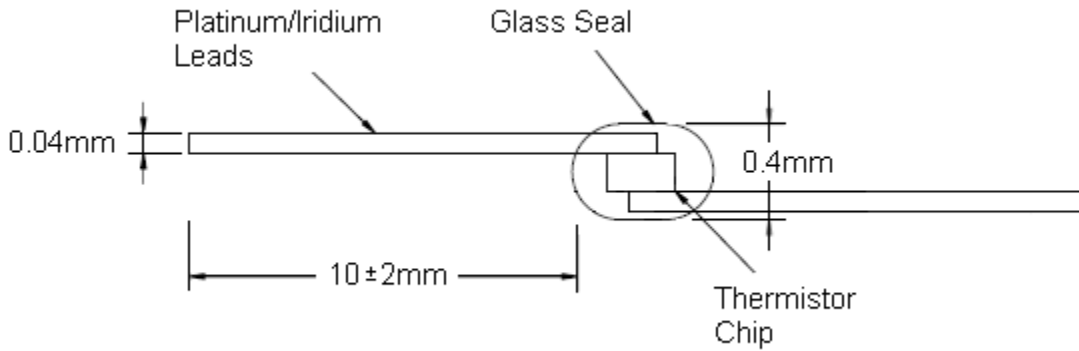

RESISTANCE V TEMPERATURE TABLE

Temp. °C	R Ohms
----------	--------

-40	217,645
-39	205,391
-38	193,904
-37	183,132
-36	173,026
-35	163,541
-34	154,635
-33	146,270
-32	138,408
-31	131,019
-30	124,069
-29	117,531
-28	111,377
-27	105,584
-26	100,127
-25	94,986
-24	90,140
-23	85,571
-22	81,261
-21	77,195
-20	73,356
-19	69,731
-18	66,308
-17	63,073
-16	60,015

Temp. °C	R Ohms
----------	--------

-15	57,124
-14	54,389
-13	51,802
-12	49,352
-11	47,034
-10	44,838
-9	42,757
-8	40,785
-7	38,916
-6	37,143
-5	35,461
-4	33,866
-3	32,351
-2	30,913
-1	29,548
0	28,250
1	27,017
2	25,845
3	24,730
4	23,670
5	22,662
6	21,702
7	20,788
8	19,918
9	19,089

Temp. °C	R Ohms
----------	--------

10	18,300
11	17,547
12	16,830
13	16,146
14	15,494
15	14,871
16	14,278
17	13,711
18	13,170
19	12,653
20	12,159
21	11,688
22	11,237
23	10,806
24	10,394
25	10,000
26	9,623
27	9,262
28	8,917
29	8,587
30	8,270
31	7,967
32	7,677
33	7,399
34	7,132

Temp. °C	R Ohms
----------	--------

35	6,877
36	6,632
37	6,397
38	6,171
39	5,955
40	5,747
41	5,548
42	5,357
43	5,173
44	4,997
45	4,828
46	4,665
47	4,508
48	4,358
49	4,213
50	4,074
51	3,940
52	3,812
53	3,688
54	3,569
55	3,454
56	3,344
57	3,237
58	3,135
59	3,036

Miniature Axial Glass Thermistor

60	2,941
61	2,850
62	2,762
63	2,677
64	2,595
65	2,515
66	2,439
67	2,366
68	2,295
69	2,226
70	2,160
71	2,096
72	2,035
73	1,975
74	1,918
75	1,862
76	1,808
77	1,757
78	1,706
79	1,658
80	1,611
81	1,566
82	1,522
83	1,480
84	1,439
85	1,399
86	1,361
87	1,324
88	1,288
89	1,253
90	1,220
91	1,187
92	1,155
93	1,125
94	1,095
95	1,067
96	1,039
97	1,012
98	986
99	960
100	936
101	912
102	889
103	866
104	845
105	824
106	803
107	783
108	764

109	745
110	727
111	710
112	692
113	676
114	660
115	644
116	629
117	614
118	599
119	585
120	572
121	559
122	546
123	533
124	521
125	509
126	498
127	486
128	475
129	465
130	455
131	444
132	435
133	425
134	416
135	407
136	398
137	389
138	381
139	373
140	365
141	357
142	350
143	342
144	335
145	328
146	322
147	315
148	309
149	302
150	296
151	290
152	284
153	279
154	273
155	268
156	262
157	257

158	252
159	247
160	242
161	238
162	233
163	229
164	224
165	220
166	216
167	212
168	208
169	204
170	200
171	196
172	193
173	189
174	186
175	182
176	179
177	176
178	172
179	169
180	166
181	163
182	160
183	158
184	155
185	152
186	150
187	147
188	144
189	142
190	139
191	137
192	135
193	132
194	130
195	128
196	126
197	124
198	122
199	120
200	118
201	116
202	114
203	112
204	110
205	108
206	107

207	105
208	103
209	102
210	100
211	98
212	97
213	95
214	94
215	92
216	91
217	90
218	88
219	87
220	86
221	84
222	83
223	82
224	80
225	79
226	78
227	77
228	76
229	75
230	74
231	73
232	71
233	70
234	69
235	68
236	67
237	66
238	65
239	65
240	64
241	63
242	62
243	61
244	60
245	59
246	59
247	58
248	57
249	56
250	55

Miniature Axial Glass Thermistor

ORDERING INFORMATION

Part Number	Description	Ω @25°C	MOQ
GA10KM3499J15	Miniature Axial Glass Thermistor	10,000	1,000*

* For quantities less than Minimum Order Quantity – Contact Distribution

NORTH AMERICA

Measurement Specialties, Inc.
910 Turnpike Road
Shrewsbury, MA 01545
Tel: 1-508-842-0516
Fax: 1-508-842-0342

Sales email:

temperature.sales.amer@meas-spec.com

EUROPE

Measurement Specialties, Inc
Ballybrit Business Park
Galway Ireland
Tel: +353-91-753238
Fax: +353-91-770789

Sales email:

temperature.sales.emea@meas-spec.com

ASIA

Measurement Specialties (China) Ltd.
No. 26 Langshan Road
Shenzhen High-Tech Park (North)
Nanshan District, Shenzhen 51807
China
Tel: +86 (0) 755 33305088
Fax: +86 (0) 755 33305099

Sales email:

temperature.sales.asia@meas-spec.com

The information in this sheet has been carefully reviewed and is believed to be accurate; however, no responsibility is assumed for inaccuracies. Furthermore, this information does not convey to the purchaser of such devices any license under the patent rights to the manufacturer. Measurement Specialties, Inc. reserves the right to make changes without further notice to any product herein. Measurement Specialties, Inc. makes no warranty, representation or guarantee regarding the suitability of its product for any particular purpose, nor does Measurement Specialties, Inc. assume any liability arising out of the application or use of any product or circuit and specifically disclaims any and all liability, including without limitation consequential or incidental damages. Typical parameters can and do vary in different applications. All operating parameters must be validated for each customer application by customer's technical experts. Measurement Specialties, Inc. does not convey any license under its patent rights nor the rights of others.