



**Silicon Sensing UK copy of  
SPP (Japan) originated**

# Product Specification

for

**CRS03-05-PS**

**Rev 4**

(Commercial Rate Sensor)

&

CRS03-05R-PS

CRS03-05S-PS



TITLE <b>PRODUCT SPECIFICATION FOR SINGLE AXIS SILICON VIBRATING STRUCTURE GYRO CRS03-05/CRS03-05R /CRS03-05S</b>	DOC. NUMBER <b>SST - 0019</b>	REV. <b>4</b>
--	----------------------------------	------------------

**NOTICE:**

User and/or Purchaser [Customer] shall indemnify and hold Silicon Sensing Systems Japan Limited ("SSSJL"), Silicon Sensing Systems Limited and its affiliates, including its members, shareholders, managers, directors, officers, employees, agents and representatives, harmless from and against any and all liabilities, claims, demands, actions, costs or expenses (including all reasonable legal or litigation costs), by whomever asserted and regardless of nature or kind, including without limitation and/or product liability claims arising from the use of any Gyro product supplied by SSSJL to [Customer], claims for personal injuries (including death) and damage to property, whether in tort or under contract, directly or indirectly, in whole or in part, attributed to or arising from the use by [Customer] of any Gyro product supplied by SSSJL to [Customer] for any purpose including but without limitation, installing the Gyro product on a product, equipment, or vehicle of any kind, or using the Gyro product for training or simulation purposes in relation to a product, equipment, or vehicle of any kind, or using the Gyro product for the support or maintenance of a product, equipment, or vehicle of any kind. SSSJL shall promptly notify [Customer] of any such claim for which indemnification will be sought. [Customer] shall have the right at its expense to assume and control the defence of such claims and SSSJL shall provide reasonable co-operation and information to [Customer] in order for [Customer] to defend the claims. [Customer] may not settle any such claim without the prior written consent of SSSJL, which consent may not be unreasonably withheld. Gyro product supplied by SSSJL is not warranted in any way for any period regardless of the existing laws and/or regulations unless agreed by and between SSSJ and [Customer] prior to purchasing. Applications that require extra reliability and quality possibly affecting the safety of living things (e.g. transport, combustion, security, etc.) or any applications which are thought to be beyond the focus of the product, should be consulted with SSS first. © Reproduction in any form prohibited. 禁無断転載 本書類の日本語部は参考用であり英語部を正とする。

住友精密工業株式会社 MEMS事業開発室
2006.8.3
SSS UK

	4	P2 : Add an alternate ASIC model(CRS03-05S). P2 : Mechanical Description revised P6 : Fig.3 added	'06.08.01	小山山川 巻口科淵	
	3	P2 : Model Number revised (RoHS Compliance) P2 : Mechanical Description revised P4 : Fig.1 amended P5 : Fig.2 added	'05.11.14	小山山川 巻南科口	
	2	P1 : Notice revised P2 : 4.Performance Current dissipation revised P4 : Fig.1 amended	'02.04.20	小山川 巻南科 中村卓 山口	
	1	P4 : Fig.1 amended	'02.10.17	徳北坂 江村本 中村卓	
	REV.	MODIFY No.	REVISED PAGES	DATE	CHECKED
	<b>Silicon Sensing Systems Japan Ltd.</b> 1-10 Fuso-cho, Amagasaki, Hyogo 660-0891 Japan Tel +81-6-6489-5868 Fax +81-6-6489-5910 E-Mail : sssj@spp.co.jp		DATE	APPROVED	CHECKED
			'01.11.16	Tokue	Kitamura
					Yoshioka Sakamoto

## 1. DESCRIPTION/概要

The silicon vibrating structure gyroscope (Si-VSG) is a solid state single axis rate sensor. It is a stand alone unit and dc output is proportional to the rate of rotation and supply voltage.

The new concept ring-shaped micro-machined resonator shows distinguished resistance against external shocks and vibrations over a wide range of temperature.

本シリコン振動ジャイロは1軸ソリッドステート角速度センサであり角速度と供給電圧に比例した直流電圧を出力する。マイクロマシニングのリング型振動子により広い温度範囲で外部衝撃や振動に対し優れた耐性を発揮するものである。

## 2. MODEL NUMBER/製品型名

CRS03 – 05	Pin output range 80deg/sec	ピン出力タイプ
CRS03 – 05R	Pin output range 80deg/sec	ピン出力タイプ(RoHS compliance / RoHS対応品)
CRS03 – 05S	Pin output range 80deg/sec	ピン出力タイプ(GOA ASIC対応品)
CRS03	Basic Model Number	基本製品番号
-xx	Design Number	タイプ識別番号
-xxR	Design Number	タイプ識別番号(RoHS compliance / RoHS対応品)
-xxS	Design Number	タイプ識別番号(GOA ASIC対応品)

## 3. MECHANICAL DESCRIPTION/外形

The nominal dimensions are shown in Fig.1,2,3 .(Fig2 RoHS compliance, Fig3 GOA ASIC model)

図1,2,3参照。(図2 RoHS対応品, 図3GOA ASIC対応品)

## 4. PERFORMANCE/性能

	Parameter 項目	Min	Typ	Max	Unit 単位	Notes 備考
Absolute Maximum Ratings 絶対最大定格	Supply voltage 電源	0.00	5.00	6.00	V	
	Storage temperature 保存温度	- 40		85	deg C	
	Operatable acceleration 使用限界加速度			981.0	m/sec <sup>2</sup>	
Operating conditions 動作環境	Supply voltage 電源電圧	4.75	5.00	5.25	V	
	Power supply noise 電源ノイズ			15.00	mVrms	0.5 to 100Hz
	Temperature 温度	- 40	23	85	deg C	
	Humidity 湿度	5		95	%RH	Non-condensing 結露無

The following specifications apply for Vdd=5.00V and Temp=23deg C unless otherwise specified.  
特に指定無き場合下記はVdd=5.00V、温度23℃を条件とする。

Parameter 項目	Limit 限度	Unit 単位	Notes 備考
Rate range 測定範囲	+/- 80	deg/sec	Reference 参考値
Rate range 測定範囲	+/- 1.396	rad/sec	
Scale Factor 感度	25	mV/(deg/sec) typ.	Reference 参考値
Scale Factor 感度	28.65	% of Vdd/(rad/sec) typ.	
Initial Scale Factor accuracy 感度初期設定確度	+/- 5	%	
Scale Factor variation with temp.感度温度変動	+/- 5	% typ.	Op temp. range 動作温度範囲
Scale Factor ratiometric error 感度電源電圧変動誤差	+/- 1	% typ.	Op voltage range動作電圧範囲
Bias ゼロ点	50	% typ. of Vdd	
Bias initial error ゼロ点初期設定誤差	+/- 100	mV	
Bias variation with temp.ゼロ点温度変動	+/- 100	mV typ.	Op temp. range 動作温度範囲
Bias ratiometric error ゼロ点電源電圧変動誤差	+/- 20	mV typ.	Op voltage range動作電圧範囲
Non linearity 非直線性	< 0.5	% of FS typ.	
Quiescent noise 静止ノイズ	< 1	mVrms typ. (3~10Hz)	
Bandwidth 帯域	> 10	Hz typ. (Gain: -3dB)	
Cross axis sensitivity 他軸感度	< 5	% typ.	
Power up time 起動時間	< 0.5	sec typ.	From Vdd = 4.50V
Current dissipation 電流消費	< 50	mA typ.	170mA when initializing(起動時)
Output Impedance 出力インピーダンス	100	Ω typ.	

## 5. TYPICAL RATE OUTPUT 出力電圧

$$V_o = \frac{1}{2} \times V_{dd} + \left( R_a \times SF \times \frac{V_{dd}}{5} \right) ; \text{ (Unit: Volt typ. 単位 V typ.)}$$

where: V<sub>o</sub>: Rateout (V), V<sub>dd</sub>: Supply voltage (V), R<sub>a</sub>: Applied rate (deg/s), SF: Scale Factor (V/ (deg/s))  
ここで: V<sub>o</sub>: ジャイロ出力(V), V<sub>dd</sub>: 電源電圧(V), R<sub>a</sub>: 角速度(deg/s), SF: 感度(V/(deg/s))

## 6. RATIOMETRIC ERROR レシオメトリック・エラー (電源電圧による変動の誤差)

### 6.1 Bias ratiometric error ゼロ点電源電圧変動誤差

Bias ratiometric error are calculated as follows; ゼロ点電源電圧変動誤差は次の式で表される

$$Err_b = V_b - \left( V_{b_5} \times \frac{V_{dd}}{5} \right) \text{ (V)}$$

where Err<sub>b</sub>: Bias ratiometric error (V), V<sub>b</sub>: Bias at V<sub>dd</sub> (V), V<sub>b<sub>5</sub></sub>: Bias at 5.00V (V), V<sub>dd</sub>: Supply voltage (V)  
ここで Err<sub>b</sub>: ゼロ点レシオメトリックエラー(V), V<sub>b</sub>: V<sub>dd</sub>でのゼロ点(V), V<sub>b<sub>5</sub></sub>: 5.00V時のゼロ点 (V), V<sub>dd</sub>: 電源電圧(V)

### 6.2 Scale Factor ratiometric error 感度電源電圧変動誤差

Scale Factor ratiometric error are calculated as follows; 感度電源電圧変動誤差は次の式で表される

$$Err_s = \left[ SF - \left( SF_5 \times \left( \frac{V_{dd}}{5} \right) \right) \right] \times \frac{100}{SF} \text{ (%)}$$

where

Err<sub>s</sub>: Scale Factor ratiometric error (%), SF: Scale Factor at V<sub>dd</sub> (V/ (deg/s))

SF<sub>5</sub>: Scale Factor at 5.00V (V/ (deg/s)), V<sub>dd</sub>: Supply voltage (V)

ここで

Err<sub>s</sub>: 感度レシオメトリックエラー(%), SF: V<sub>dd</sub>時の感度 (V/ (deg/s))

SF<sub>5</sub>: 5.00V時の感度(V/ (deg/s)), V<sub>dd</sub>: 電源電圧(V)



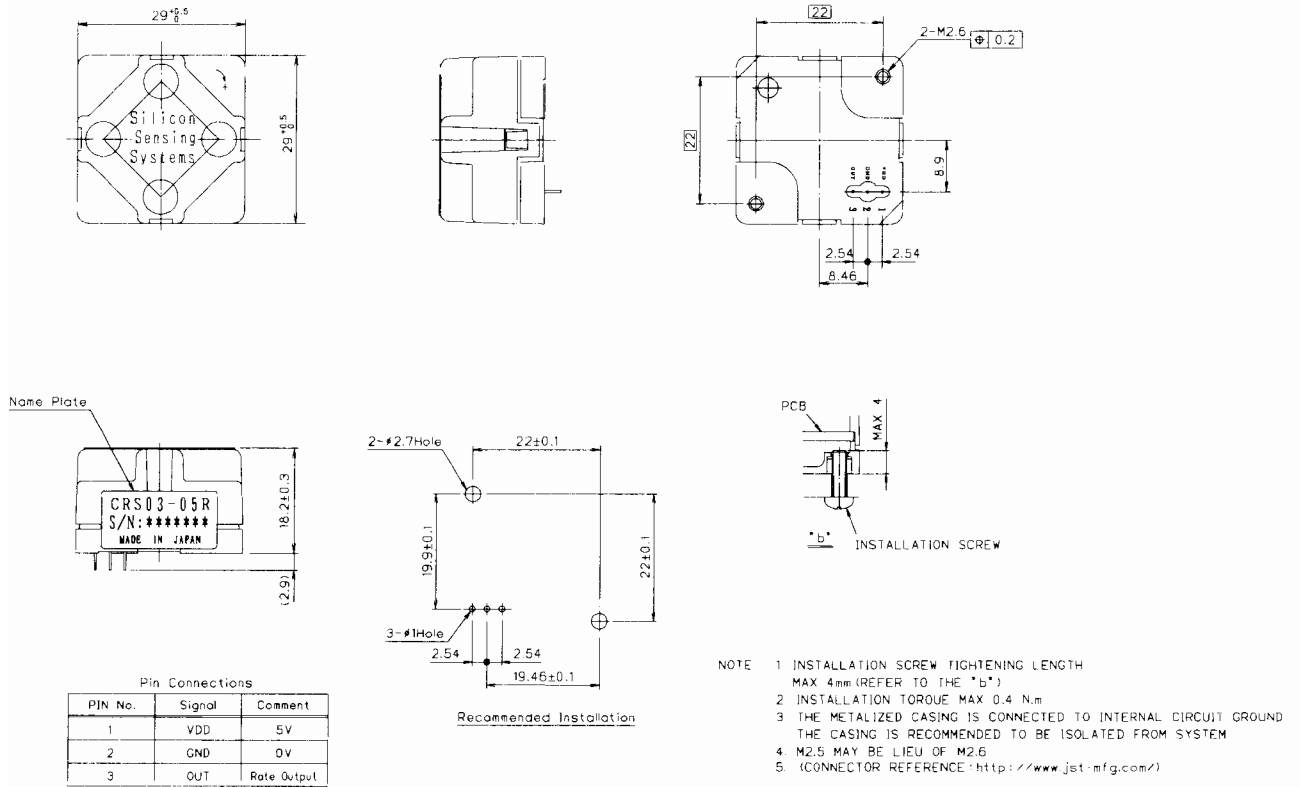

Pin Connections

PIN No.	Signal	Comment
1	VDD	5V
2	GND	0v
3	OUT	Rate Output

**Fig.2 CRS03-05R**

UNIT : mm

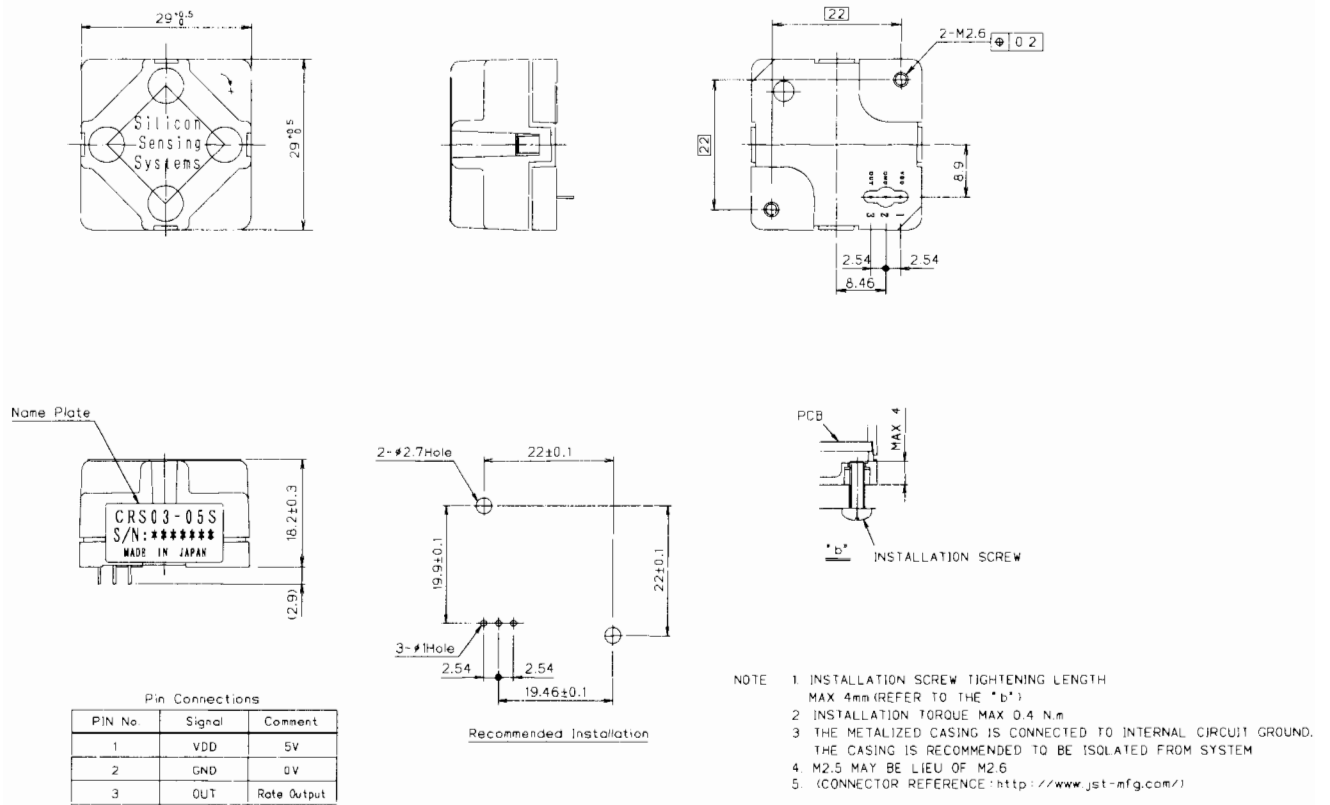

**Fig.3 CRS03-05S**

UNIT : mm