

HEF4538B

Dual precision monostable multivibrator

Rev. 8 — 16 November 2011

Product data sheet

1. General description

The HEF4538B is a dual retriggerable-resettable monostable multivibrator. Each multivibrator has an active LOW trigger/retrigger input (\overline{nA}), an active HIGH trigger/retrigger input (nB), an overriding active LOW direct reset input (\overline{nCD}), an output (nQ) and its complement (\overline{nQ}), and two pins ($nREXT/CEXT$, and $nCEXT$, always connected to ground) for connecting the external timing components C_{EXT} and R_{EXT} . Typical pulse width variation over the specified temperature range is $\pm 0.2\%$.

The multivibrator may be triggered by either the positive or the negative edges of the input pulse and will produce an accurate output pulse with a pulse width range of 10 μs to infinity. The duration and accuracy of the output pulse are determined by the external timing components C_{EXT} and R_{EXT} . The output pulse width (t_W) is equal to $R_{EXT} \times C_{EXT}$. The linear design techniques in LOCMOS (Local Oxide CMOS) guarantee precise control of the output pulse width. A LOW level at \overline{nCD} terminates the output pulse immediately. The trigger inputs' Schmitt trigger action makes the circuit highly tolerant of slower rise and fall times.

It operates over a recommended V_{DD} power supply range of 3 V to 15 V referenced to V_{SS} (usually ground). Unused inputs must be connected to V_{DD} , V_{SS} , or another input.

2. Features and benefits

- Tolerant of slow trigger rise and fall times
- Fully static operation
- 5 V, 10 V, and 15 V parametric ratings
- Standardized symmetrical output characteristics
- Specified from $-40\text{ }^\circ\text{C}$ to $+85\text{ }^\circ\text{C}$ and $-40\text{ }^\circ\text{C}$ to $+125\text{ }^\circ\text{C}$
- Complies with JEDEC standard JESD 13-B

3. Ordering information

Table 1. Ordering information

All types operate from $-40\text{ }^\circ\text{C}$ to $+125\text{ }^\circ\text{C}$.

Type number	Package		
	Name	Description	Version
HEF4538BP	DIP16	plastic dual in-line package; 16 leads (300 mil)	SOT38-4
HEF4538BT	SO16	plastic small outline package; 16 leads; body width 3.9 mm	SOT109-1



4. Functional diagram

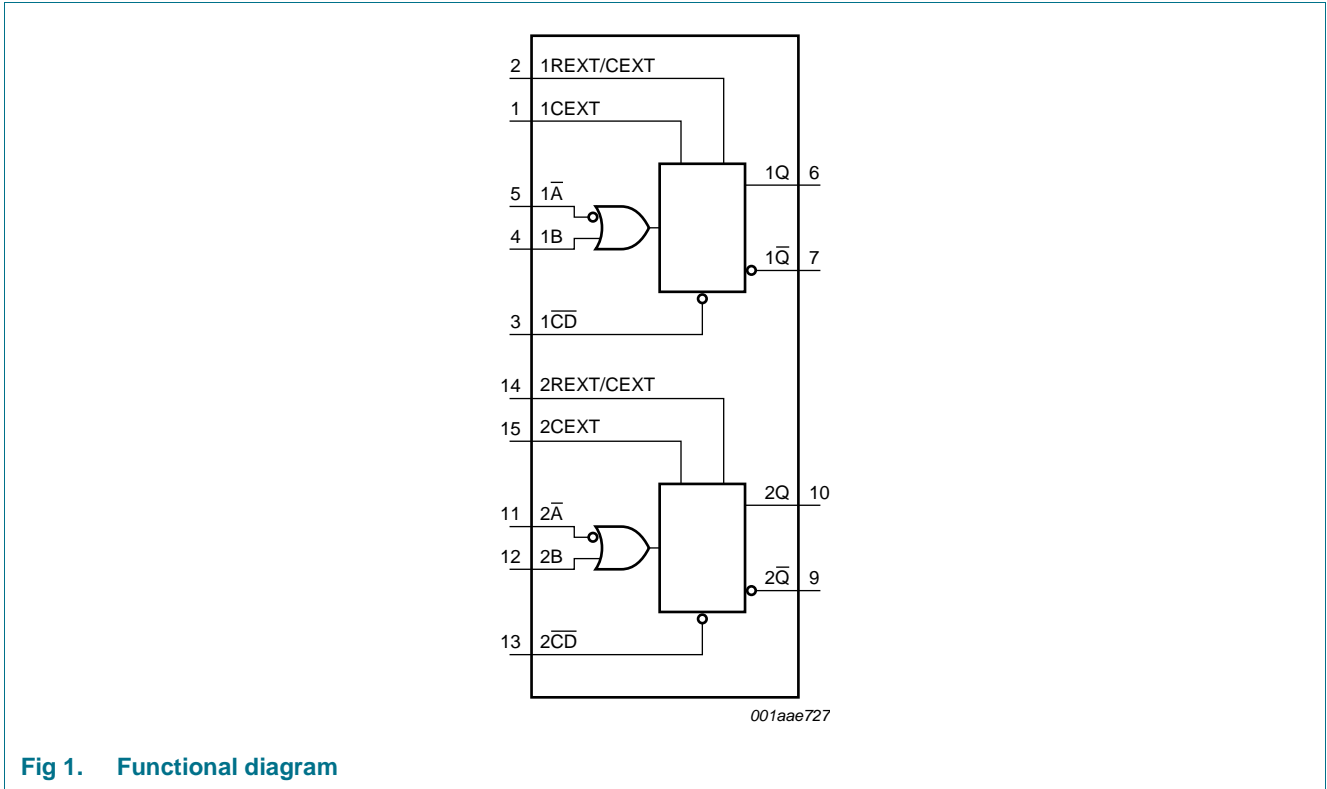

Fig 1. Functional diagram

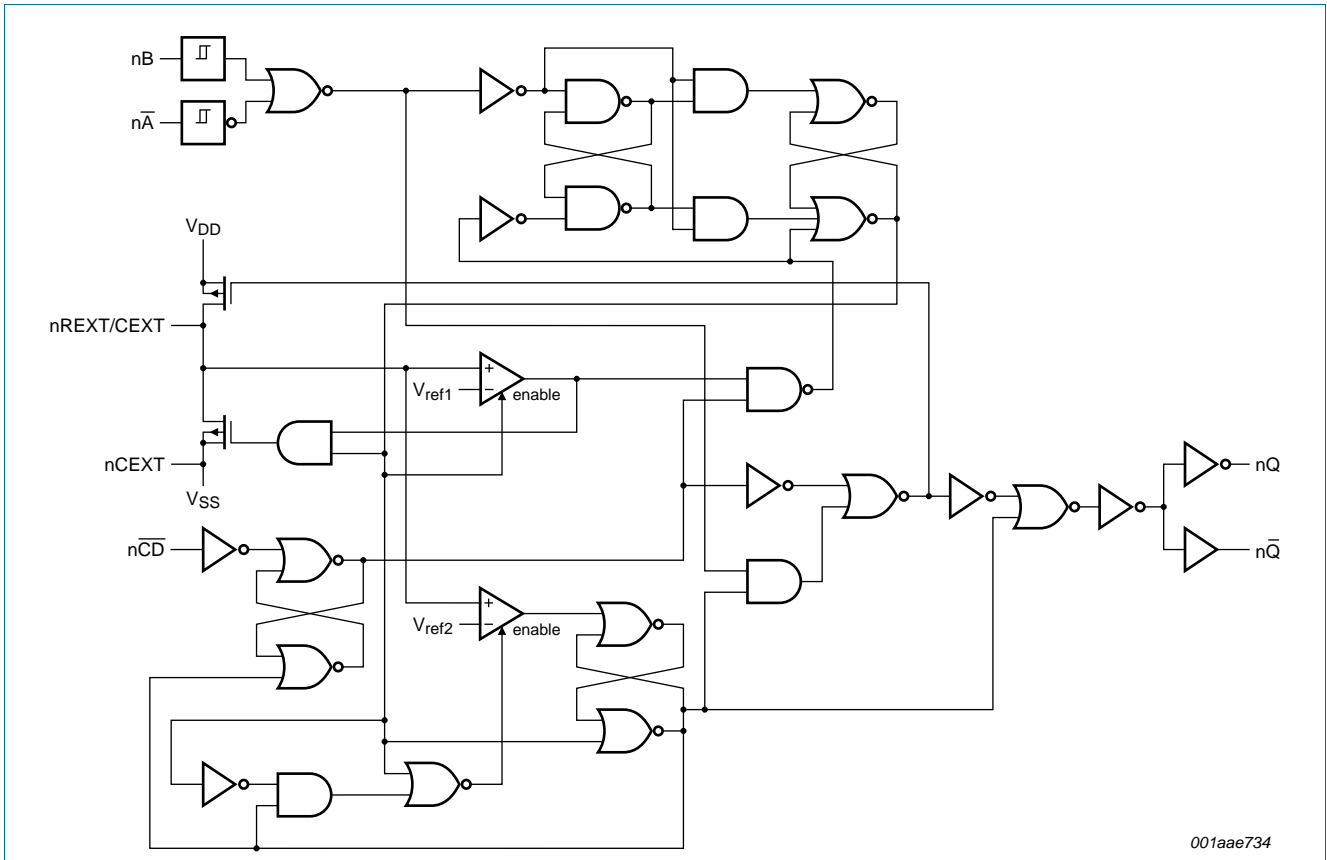

Fig 2. Logic diagram (one multivibrator)

5. Pinning information

5.1 Pinning

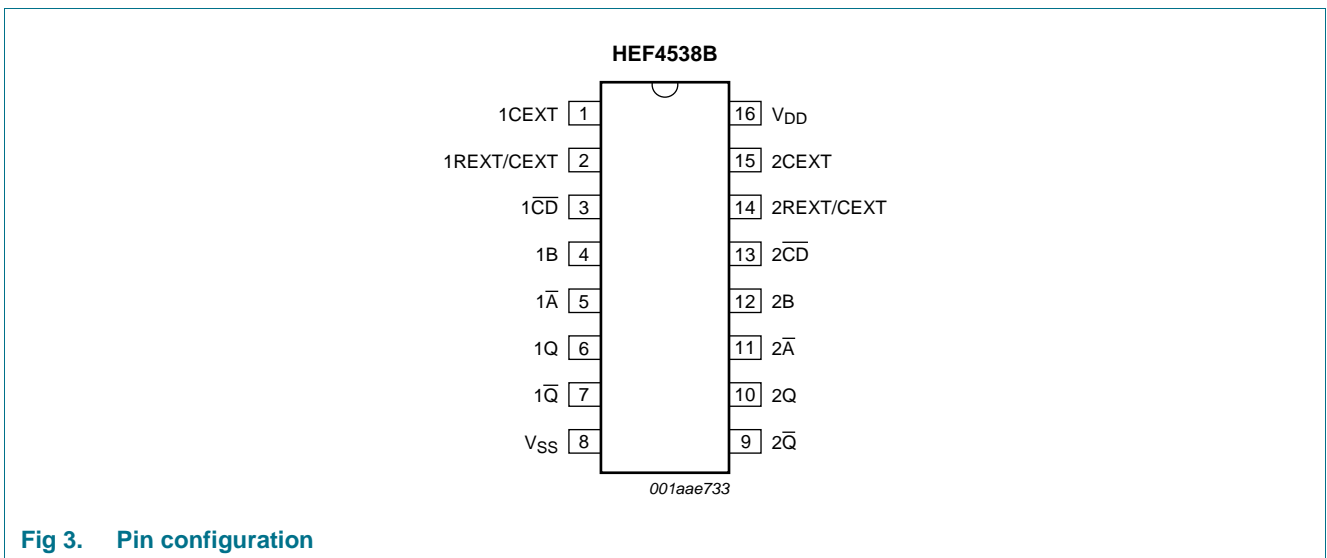

Fig 3. Pin configuration





5.2 Pin description

Table 2. Pin description

Symbol	Pin	Description
1CEXT, 2CEXT	1, 15	external capacitor connection (always connected to ground)
1REXT/CEXT, 2REXT/CEXT	2, 14	external capacitor/resistor connection
1 \overline{CD} , 2 \overline{CD}	3, 13	direct reset input (active LOW)
1B, 2B	4, 12	input (LOW-to-HIGH triggered)
1 \overline{A} , 2 \overline{A}	5, 11	input (HIGH-to-LOW triggered)
1Q, 2Q	6, 10	output
1 \overline{Q} , 2 \overline{Q}	7, 9	complementary output (active LOW)
V _{SS}	8	ground supply voltage
V _{DD}	16	supply voltage

6. Functional description

Table 3. Function table

Inputs			Outputs	
n \overline{A}	nB	n \overline{CD}	nQ	n \overline{Q}
↓	L	H		
H	↑	H		
X	X	L	L	H

[1] H = HIGH voltage level; L = LOW voltage level; X = don't care;

↑ = positive-going transition; ↓ = negative-going transition;

 = one HIGH level output pulse, with the pulse width determined by C_{EXT} and R_{EXT};

 = one LOW level output pulse, with the pulse width determined by C_{EXT} and R_{EXT}.

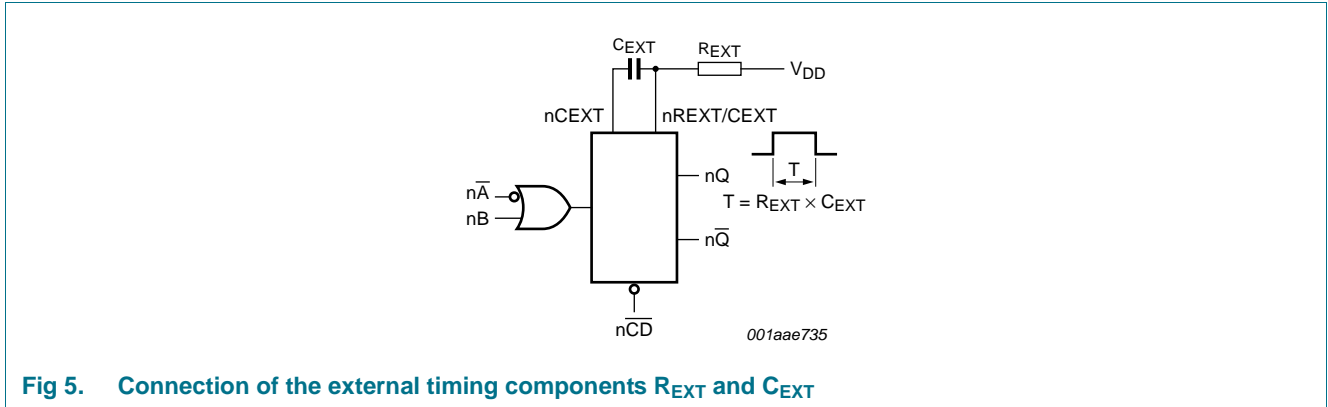
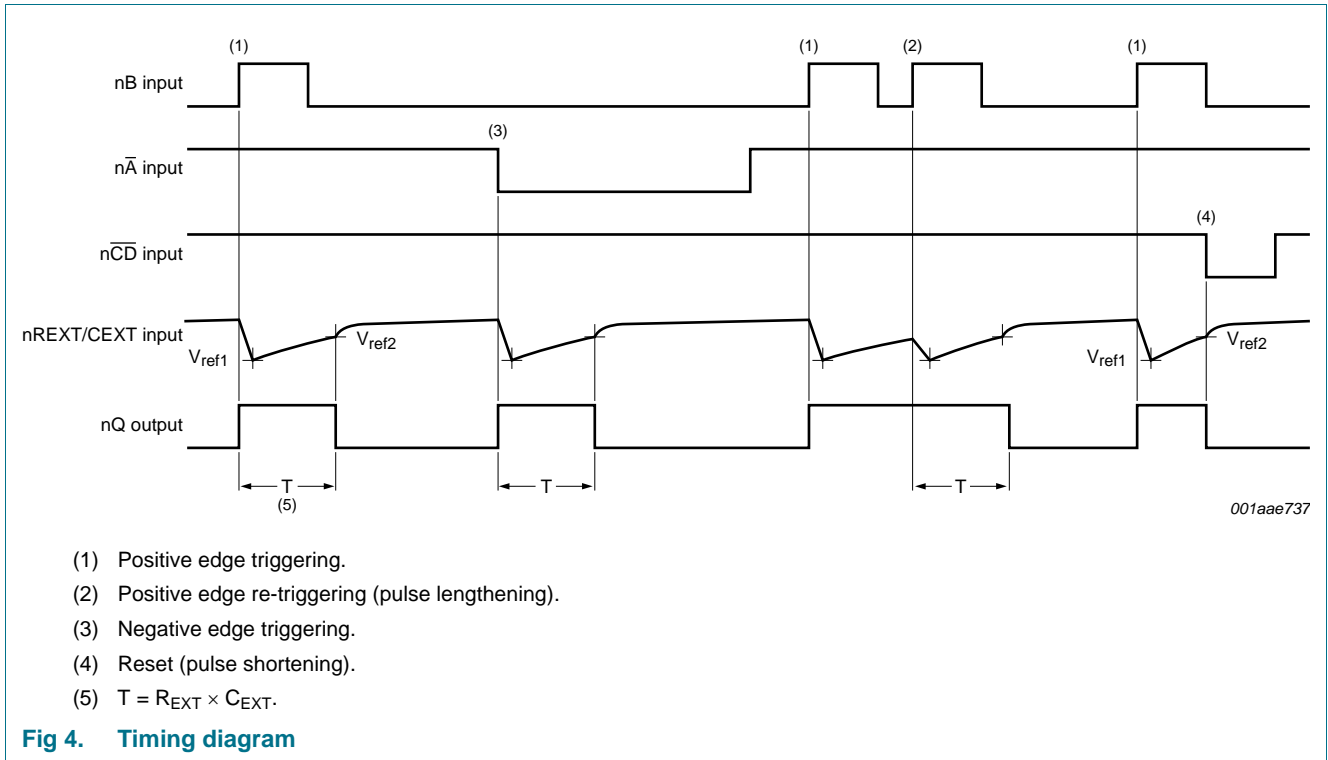

7. Limiting values

Table 4. Limiting values

In accordance with the Absolute Maximum Rating System (IEC 60134). Voltages are referenced to V_{SS} = 0 V (ground)

Symbol	Parameter	Conditions	Min	Max	Unit
V _{DD}	supply voltage		-0.5	+18	V
I _{IK}	input clamping current	V _I < -0.5 V or V _I > V _{DD} + 0.5 V	-	±10	mA
V _I	input voltage		-0.5	V _{DD} + 0.5	V
I _{OK}	output clamping current	V _I < -0.5 V or V _I > V _{DD} + 0.5 V	-	±10	mA
I _{I/O}	input/output current		-	±10	mA
I _{DD}	supply current		-	50	mA
T _{stg}	storage temperature		-65	+150	°C

Table 4. Limiting values ...continued

In accordance with the Absolute Maximum Rating System (IEC 60134). Voltages are referenced to $V_{SS} = 0$ V (ground)

Symbol	Parameter	Conditions	Min	Max	Unit
T_{amb}	ambient temperature		-40	+125	°C
P_{tot}	total power dissipation	$T_{amb} = -40$ °C to +125 °C			
		DIP16 package	[1] -	750	mW
		SO16 package	[2] -	500	mW
P	power dissipation	per output	-	100	mW

[1] For DIP16 package: P_{tot} derates linearly with 12 mW/K above 70 °C.

[2] For SO16 package: P_{tot} derates linearly with 8 mW/K above 70 °C.

8. Recommended operating conditions

Table 5. Recommended operating conditions

Symbol	Parameter	Conditions	Min	Typ	Max	Unit
V_{DD}	supply voltage		3	-	15	V
V_I	input voltage		0	-	V_{DD}	V
T_{amb}	ambient temperature	in free air	-40	-	+125	°C
$\Delta t/\Delta V$	input transition rise and fall rate	$V_{DD} = 5$ V	-	-	3.75	µs/V
		$V_{DD} = 10$ V	-	-	0.5	µs/V
		$V_{DD} = 15$ V	-	-	0.08	µs/V

9. Static characteristics

Table 6. Static characteristics

$V_{SS} = 0$ V; $V_I = V_{SS}$ or V_{DD} unless otherwise specified.

Symbol	Parameter	Conditions	V_{DD}	$T_{amb} = -40$ °C		$T_{amb} = 25$ °C		$T_{amb} = 85$ °C		$T_{amb} = 125$ °C		Unit
				Min	Max	Min	Max	Min	Max	Min	Max	
V_{IH}	HIGH-level input voltage	$ I_O < 1$ µA	5 V	3.5	-	3.5	-	3.5	-	3.5	-	V
			10 V	7.0	-	7.0	-	7.0	-	7.0	-	V
			15 V	11.0	-	11.0	-	11.0	-	11.0	-	V
V_{IL}	LOW-level input voltage	$ I_O < 1$ µA	5 V	-	1.5	-	1.5	-	1.5	-	1.5	V
			10 V	-	3.0	-	3.0	-	3.0	-	3.0	V
			15 V	-	4.0	-	4.0	-	4.0	-	4.0	V
V_{OH}	HIGH-level output voltage	$ I_O < 1$ µA	5 V	4.95	-	4.95	-	4.95	-	4.95	-	V
			10 V	9.95	-	9.95	-	9.95	-	9.95	-	V
			15 V	14.95	-	14.95	-	14.95	-	14.95	-	V
V_{OL}	LOW-level output voltage	$ I_O < 1$ µA	5 V	-	0.05	-	0.05	-	0.05	-	0.05	V
			10 V	-	0.05	-	0.05	-	0.05	-	0.05	V
			15 V	-	0.05	-	0.05	-	0.05	-	0.05	V

Table 6. Static characteristics ...continued
 $V_{SS} = 0\text{ V}$; $V_I = V_{SS}$ or V_{DD} unless otherwise specified.

Symbol	Parameter	Conditions	V _{DD}	T _{amb} = -40 °C		T _{amb} = 25 °C		T _{amb} = 85 °C		T _{amb} = 125 °C		Unit
				Min	Max	Min	Max	Min	Max	Min	Max	
I _{OH}	HIGH-level output current	V _O = 2.5 V	5 V	-	-1.7	-	-1.4	-	-1.1	-	-1.1	mA
		V _O = 4.6 V	5 V	-	-0.64	-	-0.5	-	-0.36	-	-0.36	mA
		V _O = 9.5 V	10 V	-	-1.6	-	-1.3	-	-0.9	-	-0.9	mA
		V _O = 13.5 V	15 V	-	-4.2	-	-3.4	-	-2.4	-	-2.4	mA
I _{OL}	LOW-level output current	V _O = 0.4 V	5 V	0.64	-	0.5	-	0.36	-	0.36	-	mA
		V _O = 0.5 V	10 V	1.6	-	1.3	-	0.9	-	0.9	-	mA
		V _O = 1.5 V	15 V	4.2	-	3.4	-	2.4	-	2.4	-	mA
I _I	input leakage current	nREXT/CEXT	15 V	-	±0.1	-	±0.1	-	±1.0	-	±1.0	µA
C _I	input capacitance		-	-	-	-	7.5	-	-	-	-	pF

Table 7. Typical static characteristics
 $V_{SS} = 0\text{ V}$; $V_I = V_{SS}$ or V_{DD} ; T_{amb} = +25 °C.

Symbol	Parameter	Conditions	V _{DD}	Typ	Unit	
I _{DD}	supply current	active state	5 V	1	55	µA
			10 V		150	µA
			15 V		220	µA
C _I	input capacitance	nREXT/CEXT	-	15	pF	

[1] Only one monostable is switching: for the specified current during the output pulse (output nQ is HIGH).

10. Dynamic characteristics

Table 8. Dynamic characteristics
 $V_{SS} = 0\text{ V}$; T_{amb} = 25 °C; for test circuit see [Figure 11](#).

Symbol	Parameter	Conditions	V _{DD}	Extrapolation formula ^[1]	Min	Typ	Max	Unit
t _{PHL}	HIGH to LOW propagation delay	n \bar{A} , nB to n \bar{Q} ; see Figure 6	5 V	193 ns + (0.55 ns/pF) C _L	-	220	440	ns
			10 V	74 ns + (0.23 ns/pF) C _L	-	85	190	ns
			15 V	52 ns + (0.16 ns/pF) C _L	-	60	120	ns
		n \bar{CD} to nQ; see Figure 6	5 V	98 ns + (0.55 ns/pF) C _L	-	125	250	ns
			10 V	44 ns + (0.23 ns/pF) C _L	-	55	110	ns
			15 V	32 ns + (0.16 ns/pF) C _L	-	40	80	ns
t _{PLH}	LOW to HIGH propagation delay	n \bar{A} , nB to nQ; see Figure 6	5 V	173 ns + (0.55 ns/pF) C _L	-	200	460	ns
			10 V	79 ns + (0.23 ns/pF) C _L	-	90	180	ns
			15 V	52 ns + (0.16 ns/pF) C _L	-	60	120	ns
		n \bar{CD} to n \bar{Q} ; see Figure 6	5 V	98 ns + (0.55 ns/pF) C _L	-	125	250	ns
			10 V	44 ns + (0.23 ns/pF) C _L	-	55	110	ns
			15 V	32 ns + (0.16 ns/pF) C _L	-	40	80	ns

Table 8. Dynamic characteristics ...continued
 $V_{SS} = 0\text{ V}$; $T_{amb} = 25\text{ }^{\circ}\text{C}$; for test circuit see [Figure 11](#).

Symbol	Parameter	Conditions	V_{DD}	Extrapolation formula ^[1]	Min	Typ	Max	Unit
t_{rec}	recovery time	$n\overline{CD}$ to $n\overline{A}$, nB ; see Figure 7	5 V		-	20	40	ns
			10 V		-	10	20	ns
			15 V		-	5	10	ns
t_{rtrig}	retrigger time	nQ , $n\overline{Q}$ to $n\overline{A}$, nB ; see Figure 7	5 V		0	-	-	ns
			10 V		0	-	-	ns
			15 V		0	-	-	ns
t_W	pulse width	$n\overline{A}$ LOW; minimum width; see Figure 7	5 V		90	45	-	ns
			10 V		30	15	-	ns
			15 V		24	12	-	ns
		nB HIGH; minimum width; see Figure 7	5 V		50	25	-	ns
			10 V		24	12	-	ns
			15 V		20	10	-	ns
		$n\overline{CD}$ LOW; minimum width; see Figure 7	5 V		55	25	-	ns
			10 V		25	12	-	ns
			15 V		20	10	-	ns
		nQ or $n\overline{Q}$; $R_{EXT} = 100\text{ k}\Omega$; $C_{EXT} = 2.0\text{ nF}$; see Figure 7	5 V		218	230	242	μs
			10 V		213	224	235	μs
			15 V		211	223	234	μs
		nQ or $n\overline{Q}$; $R_{EXT} = 100\text{ k}\Omega$; $C_{EXT} = 0.1\text{ }\mu\text{F}$; see Figure 7	5 V		10.3	10.8	11.3	ms
			10 V		10.2	10.7	11.2	ms
			15 V		10.1	10.6	11.1	ms
nQ or $n\overline{Q}$; $R_{EXT} = 100\text{ k}\Omega$; $C_{EXT} = 10\text{ }\mu\text{F}$; see Figure 7	5 V		1.01	1.09	1.11	s		
	10 V		0.99	1.04	1.09	s		
	15 V		0.99	1.04	1.09	s		
Δt_W	pulse width variation	nQ or $n\overline{Q}$ variation over temperature range; see Figure 8	5 V		-	± 0.2	-	%
			10 V		-	± 0.2	-	%
			15 V		-	± 0.2	-	%
	nQ or $n\overline{Q}$ variation over V_{DD} voltage range 5 V to 15 V; see Figure 9			-	± 1.5	-	%	
		nQ or $n\overline{Q}$ variation between monostables in the same device; $R_{EXT} = 100\text{ k}\Omega$; $C_{EXT} = 2\text{ nF}$ to $10\text{ }\mu\text{F}$	5 V		-	± 1	-	%
			10 V		-	± 1	-	%
R_{EXT}	external timing resistor				5	-	[2]	$\text{k}\Omega$
C_{EXT}	external timing capacitor				2000	-	no limits	pF

[1] The typical values of the propagation delay and transition times are calculated from the extrapolation formulas shown (C_L in pF).
 [2] The maximum permissible resistance R_{EXT} , which holds the specified accuracy of t_W (nQ , $n\overline{Q}$ output), depends on the leakage current of the capacitor C_{EXT} and the leakage of the HEF4538B.

11. Waveforms

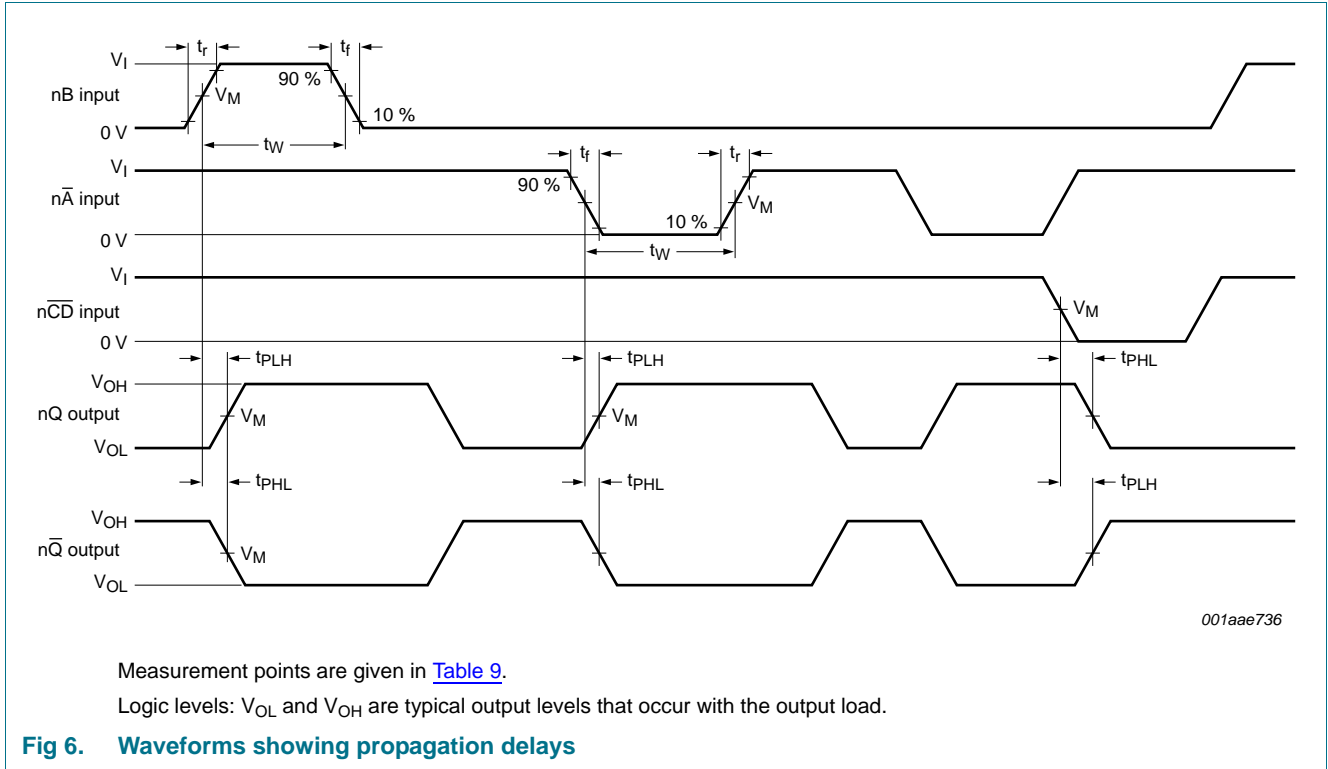
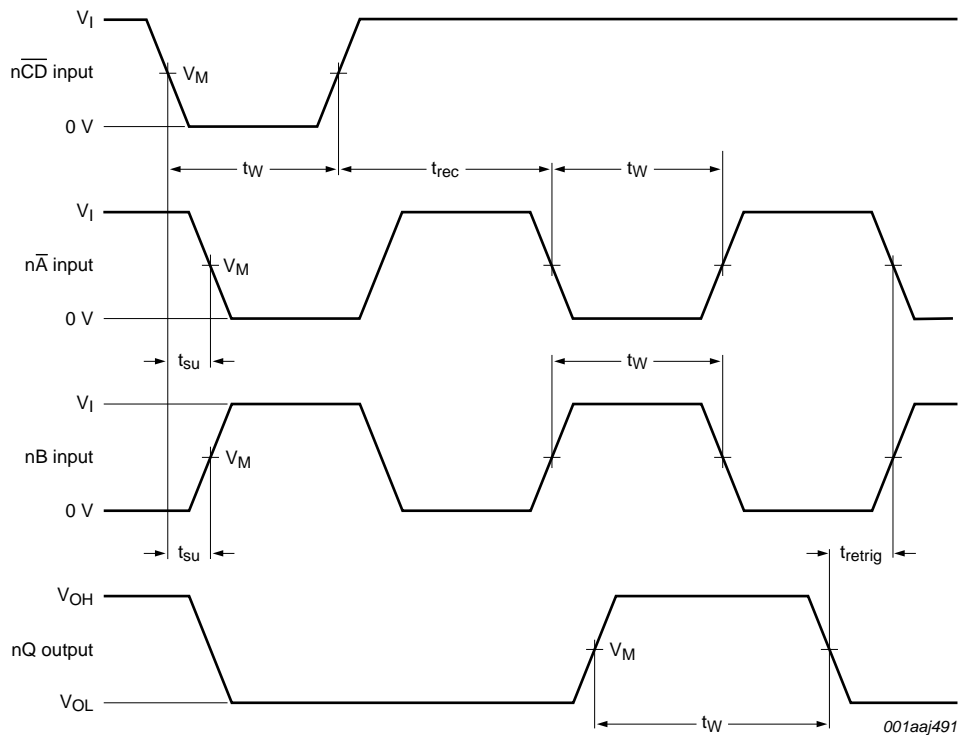

Table 9. Measurement points

Supply voltage	Input	Output
V_{DD}	V_M	V_M
5 V to 15 V	$0.5V_{DD}$	$0.5V_{DD}$



Measurement points are given in [Table 9](#).

Set-up and recovery times are shown as positive values but may be specified as negative values.

Logic levels: V_{OL} and V_{OH} are typical output levels that occur with the output load.

Fig 7. Waveforms showing minimum \overline{nA} , \overline{nB} , and \overline{nQ} pulse widths and set-up, recovery and retrigger times

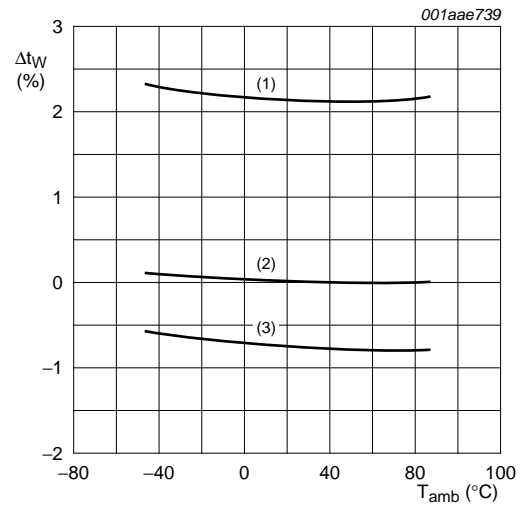
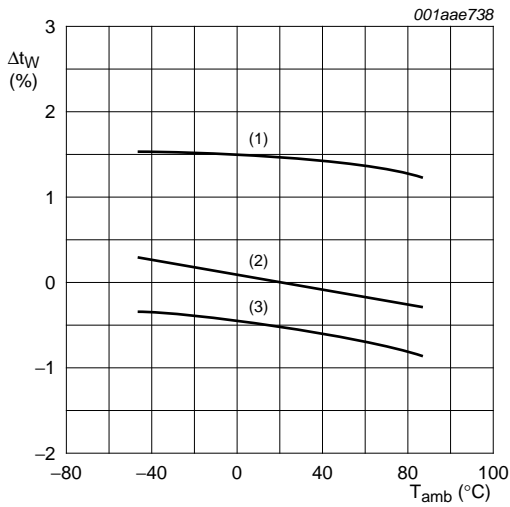

a. $R_{EXT} = 100\text{ k}\Omega$; $C_{EXT} = 100\text{ nF}$

b. $R_{EXT} = 100\text{ k}\Omega$; $C_{EXT} = 2\text{ nF}$

(1) $V_{DD} = 5\text{ V}$.

(2) $V_{DD} = 10\text{ V}$.

(3) $V_{DD} = 15\text{ V}$.

$\Delta t_W = 0\%$ at $V_{DD} = 10\text{ V}$ and $T_{amb} = 25\text{ }^\circ\text{C}$

Fig 8. Typical normalized change in output pulse width as a function of ambient temperature

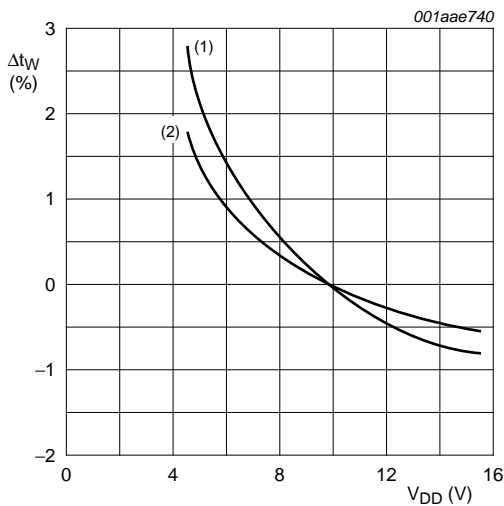

$T_{amb} = 25\text{ }^\circ\text{C}$; $\Delta t_W = 0\%$ at $V_{DD} = 10\text{ V}$; $R_{EXT} = 100\text{ k}\Omega$

(1) $C_{EXT} = 2\text{ nF}$.

(2) $C_{EXT} = 100\text{ nF}$.

Fig 9. Typical normalized change in output pulse width as a function of the supply voltage

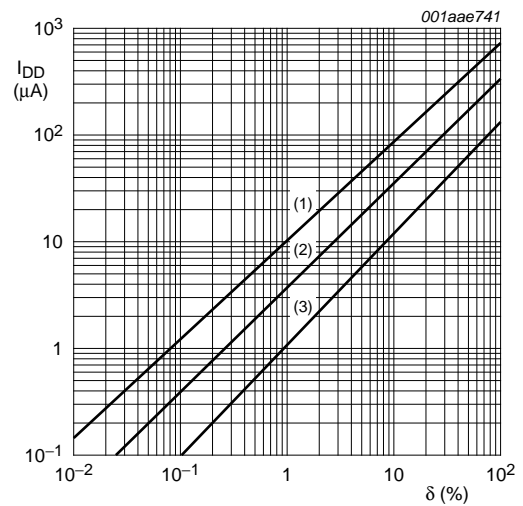

$R_{EXT} = 100\text{ k}\Omega$; $C_{EXT} = 100\text{ nF}$; $C_L = 50\text{ pF}$;
one monostable multivibrator switching only

(1) $V_{DD} = 15\text{ V}$.

(2) $V_{DD} = 10\text{ V}$.

(3) $V_{DD} = 5\text{ V}$.

Fig 10. Total supply current as a function of the output duty factor

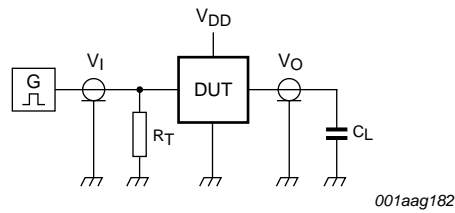

Test data is given in [Table 10](#).

Definitions for test circuit:

C_L = load capacitance including jig and probe capacitance.

R_T = termination resistance should be equal to the output impedance Z_o of the pulse generator.

Fig 11. Test circuit

Table 10. Test data

Supply voltage	Input		Load
V_{DD}	V_I	t_r, t_f	C_L
5 V to 15 V	V_{SS} or V_{DD}	≤ 20 ns	50 pF

12. Package outline

DIP16: plastic dual in-line package; 16 leads (300 mil)

SOT38-4

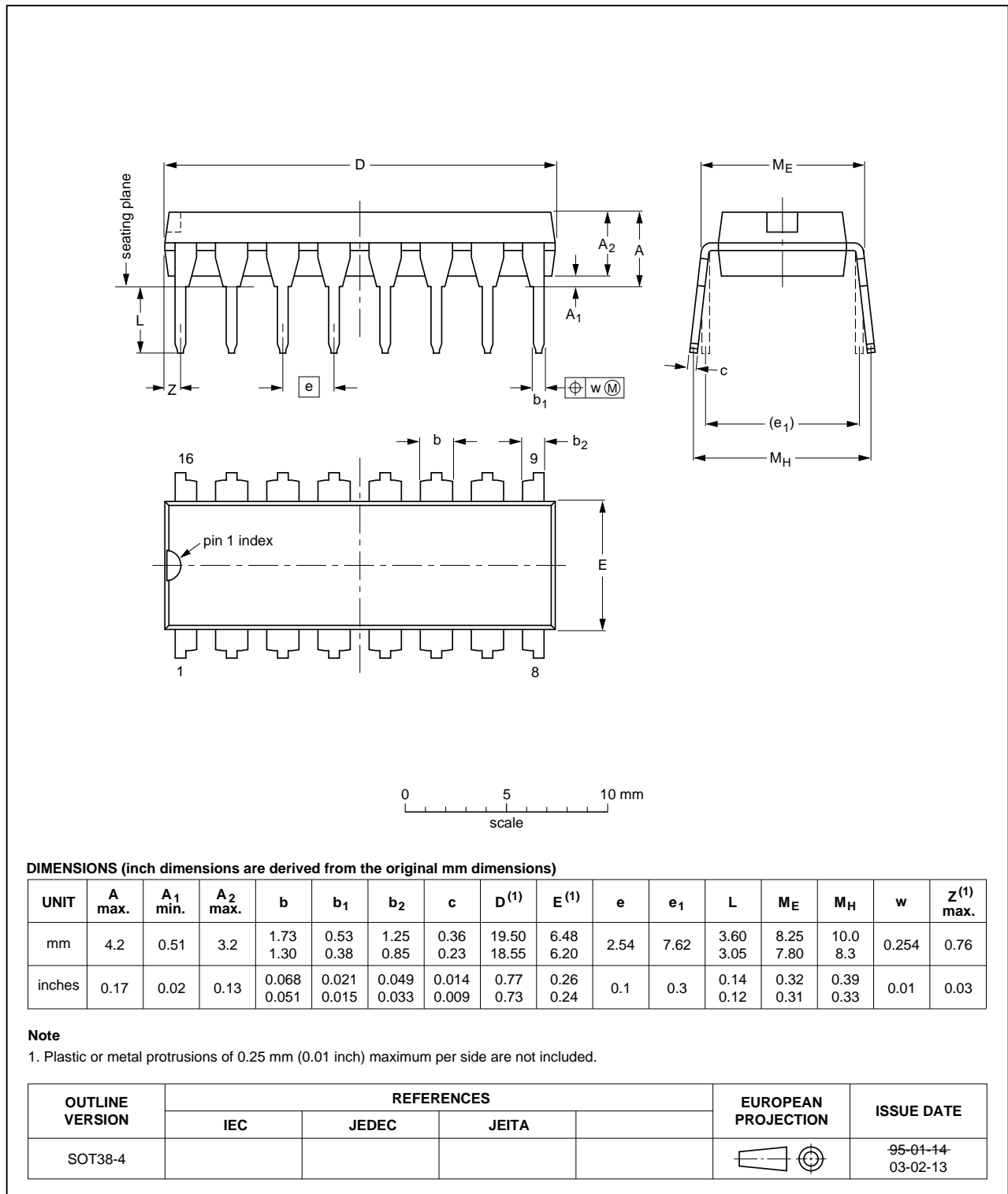

Fig 12. Package outline SOT38-4 (DIP16)

SO16: plastic small outline package; 16 leads; body width 3.9 mm

SOT109-1

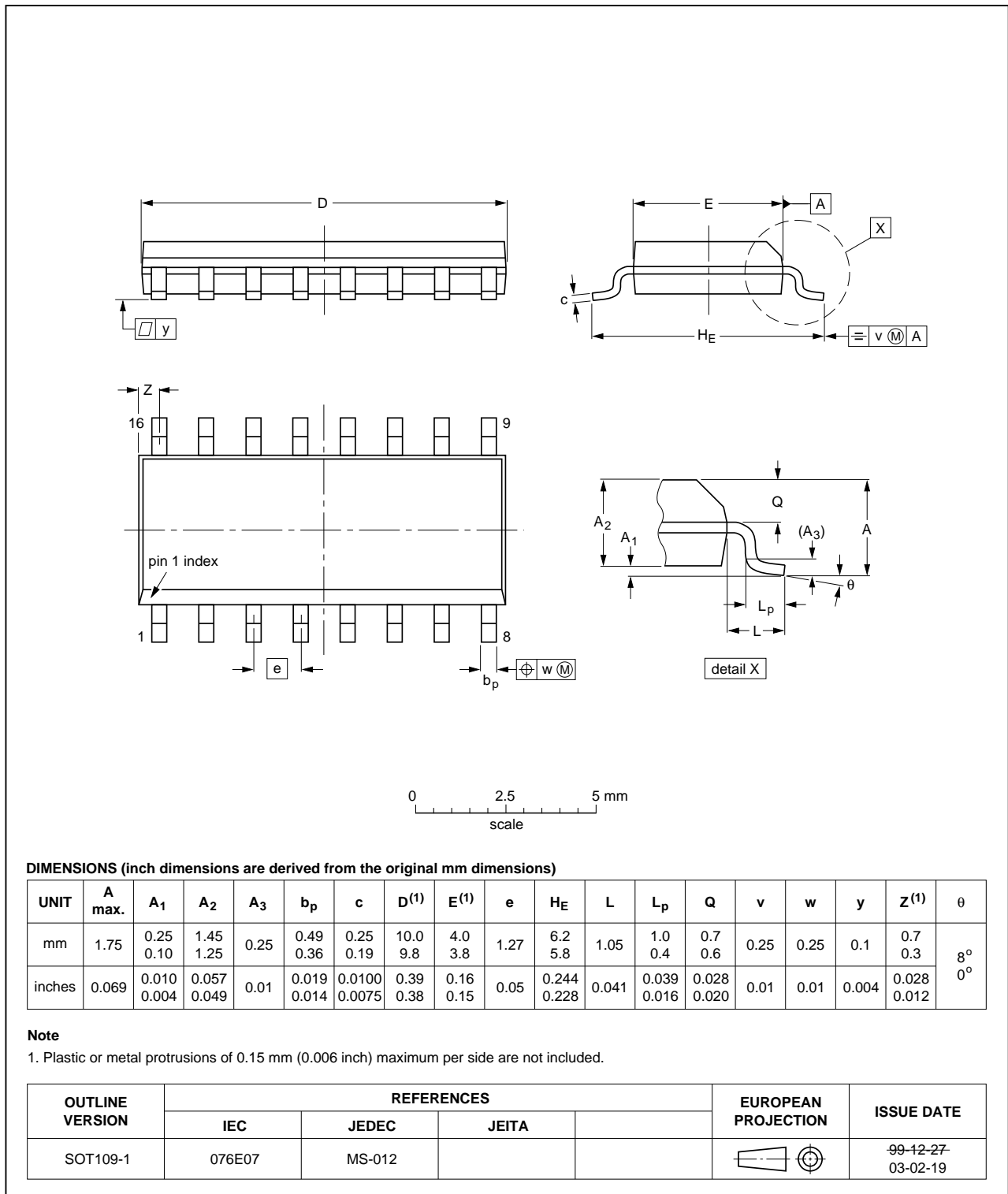

Fig 13. Package outline SOT109-1 (SO16)

13. Abbreviations

Table 11. Abbreviations

Acronym	Description
DUT	Device Under Test

14. Revision history

Table 12. Revision history

Document ID	Release date	Data sheet status	Change notice	Supersedes
HEF4538B v.8	20111116	Product data sheet	-	HEF4538B v.7
Modifications:	<ul style="list-style-type: none"> • Legal pages updated. • Changes in “General description” and “Features and benefits”. • Section “Applications” removed. 			
HEF4538B v.7	20110217	Product data sheet	-	HEF4538B v.6
HEF4538B v.6	20091102	Product data sheet	-	HEF4538B v.5
HEF4538B v.5	20090304	Product data sheet	-	HEF4538B v.4
HEF4538B v.4	20090206	Product data sheet	-	HEF4538B_CNV v.3
HEF4538B_CNV v.3	19950101	Product specification	-	HEF4538B_CNV v.2
HEF4538B_CNV v.2	19950101	Product specification	-	-

15. Legal information

15.1 Data sheet status

Document status ^{[1][2]}	Product status ^[3]	Definition
Objective [short] data sheet	Development	This document contains data from the objective specification for product development.
Preliminary [short] data sheet	Qualification	This document contains data from the preliminary specification.
Product [short] data sheet	Production	This document contains the product specification.

[1] Please consult the most recently issued document before initiating or completing a design.

[2] The term 'short data sheet' is explained in section "Definitions".

[3] The product status of device(s) described in this document may have changed since this document was published and may differ in case of multiple devices. The latest product status information is available on the Internet at URL <http://www.nxp.com>.

15.2 Definitions

Draft — The document is a draft version only. The content is still under internal review and subject to formal approval, which may result in modifications or additions. NXP Semiconductors does not give any representations or warranties as to the accuracy or completeness of information included herein and shall have no liability for the consequences of use of such information.

Short data sheet — A short data sheet is an extract from a full data sheet with the same product type number(s) and title. A short data sheet is intended for quick reference only and should not be relied upon to contain detailed and full information. For detailed and full information see the relevant full data sheet, which is available on request via the local NXP Semiconductors sales office. In case of any inconsistency or conflict with the short data sheet, the full data sheet shall prevail.

Product specification — The information and data provided in a Product data sheet shall define the specification of the product as agreed between NXP Semiconductors and its customer, unless NXP Semiconductors and customer have explicitly agreed otherwise in writing. In no event however, shall an agreement be valid in which the NXP Semiconductors product is deemed to offer functions and qualities beyond those described in the Product data sheet.

15.3 Disclaimers

Limited warranty and liability — Information in this document is believed to be accurate and reliable. However, NXP Semiconductors does not give any representations or warranties, expressed or implied, as to the accuracy or completeness of such information and shall have no liability for the consequences of use of such information.

In no event shall NXP Semiconductors be liable for any indirect, incidental, punitive, special or consequential damages (including - without limitation - lost profits, lost savings, business interruption, costs related to the removal or replacement of any products or rework charges) whether or not such damages are based on tort (including negligence), warranty, breach of contract or any other legal theory.

Notwithstanding any damages that customer might incur for any reason whatsoever, NXP Semiconductors' aggregate and cumulative liability towards customer for the products described herein shall be limited in accordance with the *Terms and conditions of commercial sale* of NXP Semiconductors.

Right to make changes — NXP Semiconductors reserves the right to make changes to information published in this document, including without limitation specifications and product descriptions, at any time and without notice. This document supersedes and replaces all information supplied prior to the publication hereof.

Suitability for use — NXP Semiconductors products are not designed, authorized or warranted to be suitable for use in life support, life-critical or safety-critical systems or equipment, nor in applications where failure or

malfunction of an NXP Semiconductors product can reasonably be expected to result in personal injury, death or severe property or environmental damage. NXP Semiconductors accepts no liability for inclusion and/or use of NXP Semiconductors products in such equipment or applications and therefore such inclusion and/or use is at the customer's own risk.

Applications — Applications that are described herein for any of these products are for illustrative purposes only. NXP Semiconductors makes no representation or warranty that such applications will be suitable for the specified use without further testing or modification.

Customers are responsible for the design and operation of their applications and products using NXP Semiconductors products, and NXP Semiconductors accepts no liability for any assistance with applications or customer product design. It is customer's sole responsibility to determine whether the NXP Semiconductors product is suitable and fit for the customer's applications and products planned, as well as for the planned application and use of customer's third party customer(s). Customers should provide appropriate design and operating safeguards to minimize the risks associated with their applications and products.

NXP Semiconductors does not accept any liability related to any default, damage, costs or problem which is based on any weakness or default in the customer's applications or products, or the application or use by customer's third party customer(s). Customer is responsible for doing all necessary testing for the customer's applications and products using NXP Semiconductors products in order to avoid a default of the applications and the products or of the application or use by customer's third party customer(s). NXP does not accept any liability in this respect.

Limiting values — Stress above one or more limiting values (as defined in the Absolute Maximum Ratings System of IEC 60134) will cause permanent damage to the device. Limiting values are stress ratings only and (proper) operation of the device at these or any other conditions above those given in the Recommended operating conditions section (if present) or the Characteristics sections of this document is not warranted. Constant or repeated exposure to limiting values will permanently and irreversibly affect the quality and reliability of the device.

Terms and conditions of commercial sale — NXP Semiconductors products are sold subject to the general terms and conditions of commercial sale, as published at <http://www.nxp.com/profile/terms>, unless otherwise agreed in a valid written individual agreement. In case an individual agreement is concluded only the terms and conditions of the respective agreement shall apply. NXP Semiconductors hereby expressly objects to applying the customer's general terms and conditions with regard to the purchase of NXP Semiconductors products by customer.

No offer to sell or license — Nothing in this document may be interpreted or construed as an offer to sell products that is open for acceptance or the grant, conveyance or implication of any license under any copyrights, patents or other industrial or intellectual property rights.

Export control — This document as well as the item(s) described herein may be subject to export control regulations. Export might require a prior authorization from competent authorities.

Non-automotive qualified products — Unless this data sheet expressly states that this specific NXP Semiconductors product is automotive qualified, the product is not suitable for automotive use. It is neither qualified nor tested in accordance with automotive testing or application requirements. NXP Semiconductors accepts no liability for inclusion and/or use of non-automotive qualified products in automotive equipment or applications.

In the event that customer uses the product for design-in and use in automotive applications to automotive specifications and standards, customer (a) shall use the product without NXP Semiconductors' warranty of the product for such automotive applications, use and specifications, and (b) whenever customer uses the product for automotive applications beyond

NXP Semiconductors' specifications such use shall be solely at customer's own risk, and (c) customer fully indemnifies NXP Semiconductors for any liability, damages or failed product claims resulting from customer design and use of the product for automotive applications beyond NXP Semiconductors' standard warranty and NXP Semiconductors' product specifications.

15.4 Trademarks

Notice: All referenced brands, product names, service names and trademarks are the property of their respective owners.

16. Contact information

For more information, please visit: <http://www.nxp.com>

For sales office addresses, please send an email to: salesaddresses@nxp.com

17. Contents

1	General description	1
2	Features and benefits	1
3	Ordering information	1
4	Functional diagram	2
5	Pinning information	3
5.1	Pinning	3
5.2	Pin description	4
6	Functional description	4
7	Limiting values	5
8	Recommended operating conditions	6
9	Static characteristics	6
10	Dynamic characteristics	7
11	Waveforms	9
12	Package outline	13
13	Abbreviations	15
14	Revision history	15
15	Legal information	16
15.1	Data sheet status	16
15.2	Definitions	16
15.3	Disclaimers	16
15.4	Trademarks	17
16	Contact information	17
17	Contents	18

Please be aware that important notices concerning this document and the product(s) described herein, have been included in section 'Legal information'.

© NXP B.V. 2011.

All rights reserved.

For more information, please visit: <http://www.nxp.com>

For sales office addresses, please send an email to: salesaddresses@nxp.com

Date of release: 16 November 2011

Document identifier: HEF4538B