

Introduction

The Pyxos platform is a high-speed sensor network ideal both for stand-alone applications and the ones extending LONWORKS® networks down to sensor and actuator I/Os. It can be used inside machines and in other high-performance systems.

Pyxos embedded control networks reduce product installation, warranty, and life-cycle costs. Pyxos self-organizing networks reduce installation costs and equipment assembly time by eliminating the need to use special tools or skilled labor for network configuration. This minimizes material and labor costs. The remote diagnostics afforded by the Pyxos platform enable new features that let manufacturers access low-level data from sensors and actuators, such as process efficiency and energy usage. Employing these features for preventive and predictive maintenance provides reduced life-cycle costs and improved customer service.

The Pyxos FT network chip embeds both the protocol for a Pyxos platform and the transceiver for communicating on the Pyxos network. With the networking protocol implemented inside the chip, only application development is left to the user. The chip has a small size (5mm x 5mm) that fits into virtually any sensor or actuator. The chip can be connected directly to digital I/O without a microcontroller, making for an ultra-compact smart

- ▼ Low-cost embedded control networking chip for use inside machines and for extending control networks to high-performance sensor networks
- ▼ Miniaturized form factor fits into almost every sensor and actuator
- ▼ Extensible architecture for seamless integration with LONWORKS® control networks and the Internet
- ▼ Self-organizing feature configures the network without special tools or skilled labor
- ▼ High-speed deterministic operation ($\leq 25\text{ms}$ response time)
- ▼ 312.5kbps network transmission speed
- ▼ Polarity-insensitive, free topology, twisted pair wiring
- ▼ Link power allows sending communication and power over same pair of wires
- ▼ Robust performance ideal for industrial and consumer products and applications including automotive, buildings, office machines, and transportation
- ▼ Exceptional data integrity with forward error correction and 18-bit packet CRC
- ▼ Exceptionally high common mode noise and interference immunity
- ▼ Network pins ESD protection to over 8kV HBM
- ▼ -40°C to $+85^{\circ}\text{C}$ operating temperature range
- ▼ 20 Pin QFN 5mm x 5mm package
- ▼ RoHS-compliant

device. Alternately, the chip's serial peripheral interface (SPI) port can be interfaced with a wide variety of low-cost microcontrollers to accommodate more complex I/O requirements.

Network Architecture and Components

A Pyxos FT network consists of up to 32 Pyxos Points embedded inside sensors and actuators, and a Pyxos Pilot to interface with the outside world or other Pyxos Pilots. Points (Figure 2) can either be *unhosted* (without a micro-

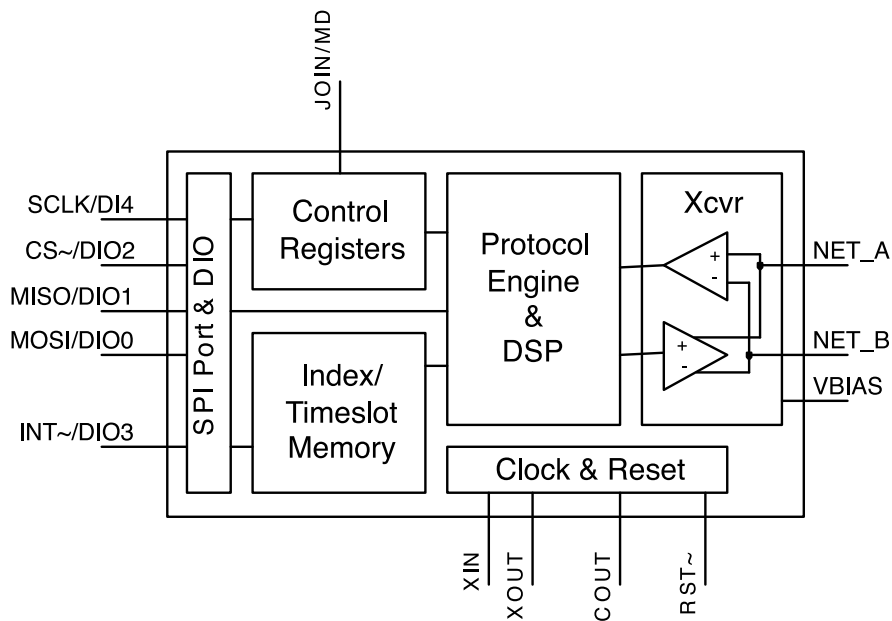

Figure 1. Pyxos FT Transceiver Block Diagram

controller; with only digital I/Os) or *hosted* (with a microcontroller). Pilots (Figure 3) need a microcontroller and can either be *stand-alone* (not connected to any external network) or *networked* (connected to a higher-level external network e.g., LONWORKS to communicate with the outside world or with other Pyxos Pilots).

High Speed Deterministic Response Time

A Pyxos FT network operates at 312.5 kilobits per second using a deterministic signaling method by which all 32 Points in the system are scanned every 25 milliseconds (proportionally faster with fewer Points in the system). This rate of speed allows Pyxos FT networks to be used for closed-loop controls in process and industrial applications, as well as sensing and control applications that require fast response time.

Potential applications include:

- vehicular controls
- propulsion controls
- lighting systems
- security and fire/life safety devices
- office automation equipment
- fault monitors
- HVAC systems
- burner and boiler controls
- elevator cab and floor call controls

Advanced Noise Immunity

Four different network coupling options are available to cover a wide variety of application environments. For applications within an enclosure, the differential receiver in the Pyxos FT IC provides rail-to-rail common mode range and may be connected directly to the network with no additional components. For network applications where AC mains based common mode noise may be tens of volts, a simple 4 component coupling circuit provides +/-40V 50/60Hz common mode range (far better than typical RS-485 transceivers). For extremely harsh noise environments a transformer coupled option provides a common mode range of 277VAC at 50/60Hz and >50Vpp immunity to higher frequency common mode noise - passing the highest level of EN61000-4-6 conducted RF immunity.

Free Topology Wiring and Link Power

A Pyxos FT network sends both power and data on the same wire pair, a feature known as "Link Power". Link power eliminates the need for an additional pair of power wires and interface terminals, further reducing the cost, size, and complexity of Pyxos FT Points. Pyxos FT

networks support free topology wiring architecture that allows network cabling in star, loop, daisy chain, or bus topology or any combination of these. Free topology wiring reduces the time and expense of device installation by allowing the wiring to be installed in the most expeditious and cost-effective manner.

controllers (PLCs), data gathering panels, host processors, LONWORKS control networks, the Internet, and beyond. The published API makes it easy to interface with the Pyxos Pilot. The Pyxos API uses the same data type definitions as those developed for LONWORKS networks, making integration with LONWORKS networks seamless.

Seamless Integration with Outside World

Control information gathered from Pyxos FT Points is disseminated by a Pyxos FT Pilot to programmable logic

Block Diagrams

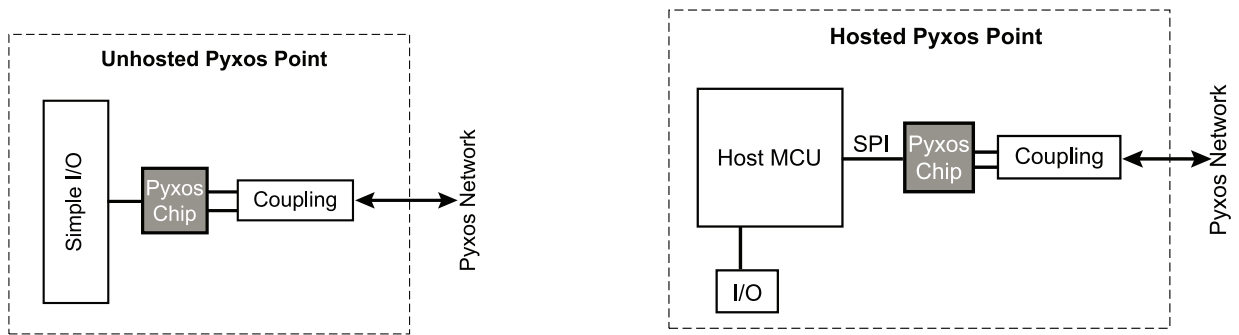

Figure 2. Example Pyxos Point

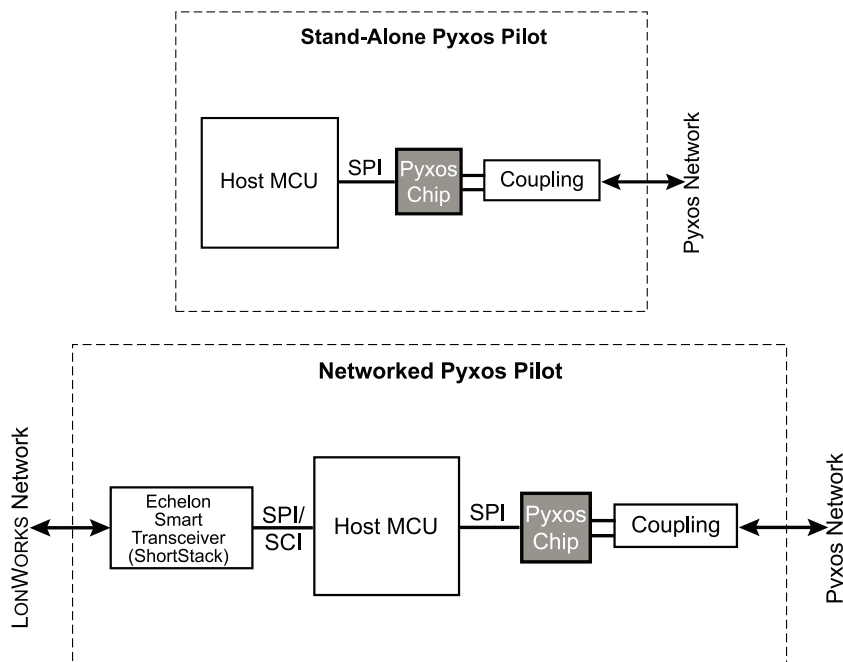
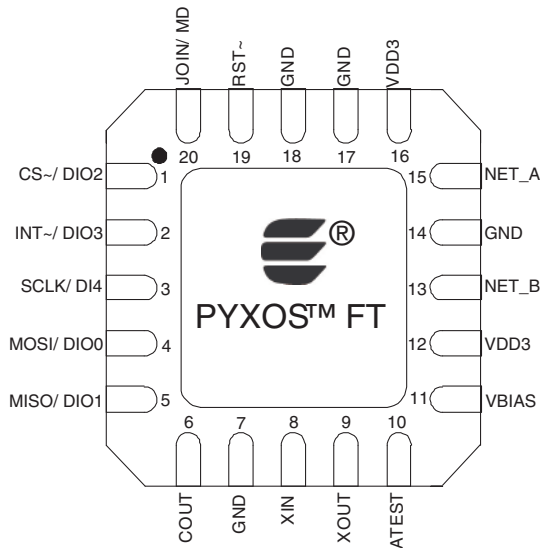

Figure 3. Example Pyxos Pilot

Pin Configuration



Note: There is an exposed die paddle (Pin 21) on the underside of the chip package. This must not be connected to any voltage or signal line on the PCB.

Name	Pin Number	Type	Pin Description
CS~/ DIO2	1	Digital I/O	Chip Select Input or DIO2
INT~/ DIO3	2	Digital I/O	Interrupt Output or DIO3
SCLK/ DI4	3	Digital In	SPI Clock Input or DI4
MOSI/ DIO0	4	Digital I/O	SPI Input or DIO0
MISO/ DIO1	5	Digital I/O	SPI Output or DIO1
COUT	6	Digital Out	Clock output/tri-state
GND	7	Ground	Ground
XIN	8	Osc In	Crystal Oscillator In
XOUT	9	Osc Out	Crystal Oscillator Out
ATEST	10	Analog I/O	Analog Test
VBIAS	11	Analog Out	Network Bias Voltage Output
VDD3	12	Power	3.3V Power
NET_B	13	Analog I/O	Network TX/RX
GND	14	Ground	Ground
NET_A	15	Analog I/O	Network TX/RX
VDD3	16	Power	3.3V Power
GND	17	Ground	Ground
GND	18	Ground	Ground
RST~	19	Digital I/O	Reset Input/Output
JOIN/MD	20	Digital In	Join/Mode pin Input
PAD	21	Do Not Connect	Do Not Connect

Pad Layout

The center pad in the pad layout is connected to ground. However, the solder stencil mask isolates the center pad on the PCB from the exposed die paddle on the underside of the chip.

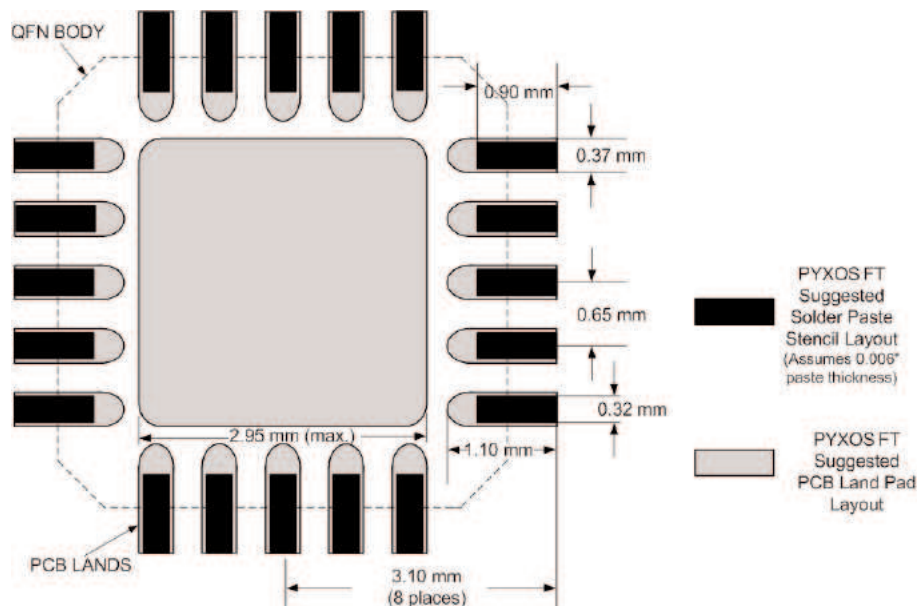

Package Diagrams

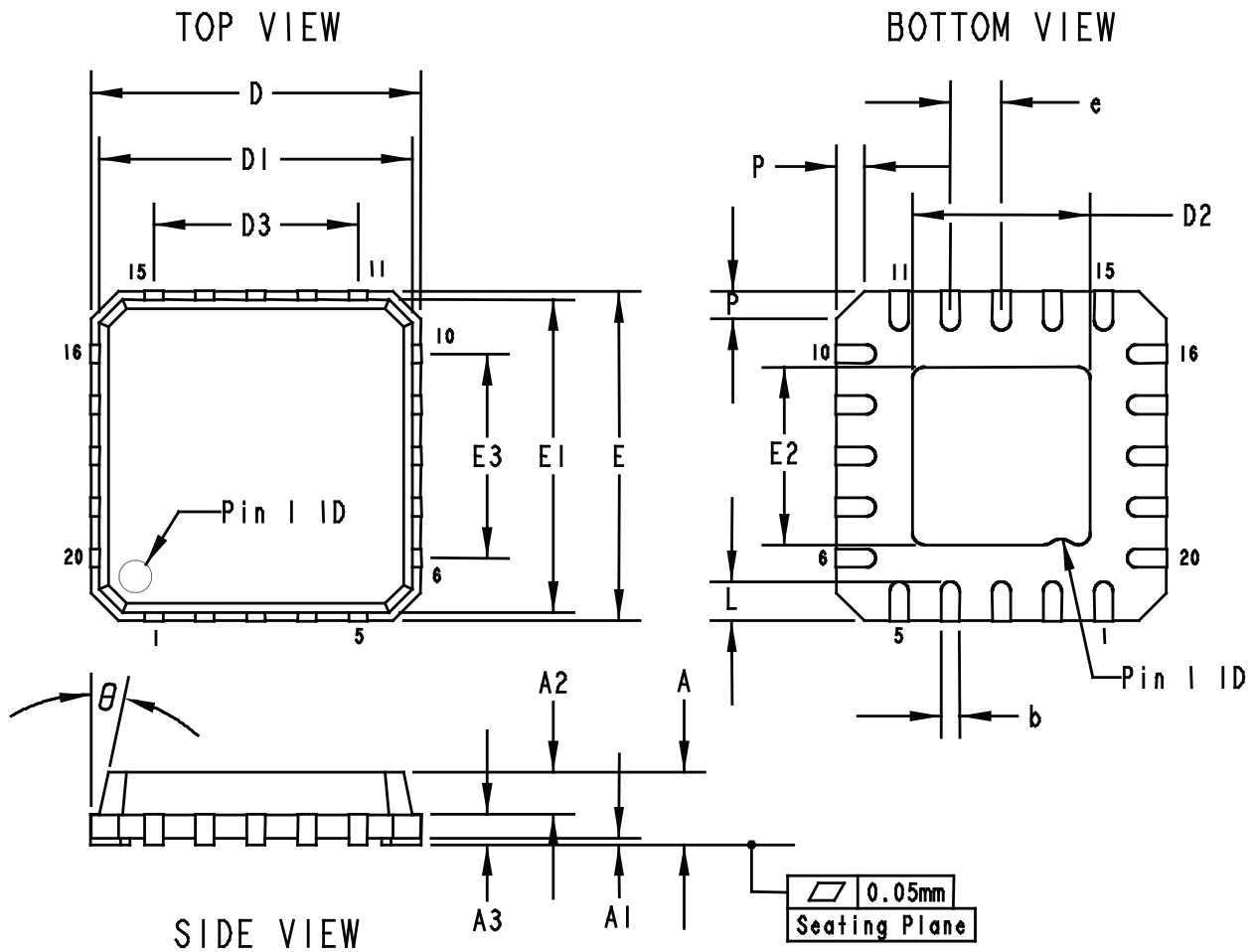

Symbol	mm (prevailing dimensions)			Inch		
	Min.	Nom.	Max.	Min.	Nom.	Max.
A	-	0.85	1.00	-	0.033	0.039
A1	-	0.01	0.05	-	0.0004	0.0020
A2	-	0.65	0.80	-	0.025	0.031
A3	-	0.20 REF	-	-	0.008 REF	-
b	0.23	0.28	0.35	0.009	0.011	0.014
D	5.00 BSC			0.197 BSC		
D1	4.75 BSC			0.187 BSC		
D2	2.95	3.10	3.25	0.116	0.122	0.128
D3	2.60 BSC			0.102 BSC		
e	0.65 BSC			0.026 BSC		
E	5.00 BSC			0.197 BSC		
E1	4.75 BSC			0.187 BSC		
E2	2.95	3.10	3.25	0.116	0.122	0.128
E3	2.60 BSC			0.102 BSC		
L	0.50	0.60	0.75	0.020	0.024	0.030
P	0.24	0.42	0.60	0.009	0.017	0.024
θ	-	-	12°	-	-	12°

General Specifications

Features	Description
Network Connections	Polarity-insensitive
Protocol	Deterministic TDM protocol with automatic retries on CRC error
Response Time (reading and writing two 4-byte values in each scan)	≤25ms scan time for up to 32 Points. Scan time is proportionally faster with less Pyxos Points, e.g., 1.8ms for two Pyxos Points in the system
Data Integrity	Forward error correction of up to 2 bit errors per packet; 18 bit packet CRC
MAC ID	Built-in
Installation	Self-organizing network with automatic, hardwired, or manual service-pin methods
Maximum Pyxos Points per Pyxos Pilot	32
Transmission Speed	312.5 kilobits per second, fixed polling cycle
Pyxos Network Variables (PNVs) per hosted Pyxos Point	Up to 128 PNVs per Pyxos Point. A maximum of 512 bytes may be used for PNVs, with memory allocated in 32-bit increments. A PNV may be 1 to 32 bytes.
LONWORKS Network Variables per Pyxos Pilot	62 when using ShortStack, 4096 when using MIP
Network Wiring	Unshielded CAT-5 24AWG (0.5mm) and Belden 8471 16AWG (1.3mm) twisted pair wire; see Junction Box and Wiring Guidelines application note for cable details
Network Length in Free Topology	Free Topology (Single termination): 100m (328 feet) maximum total wire Bus Topology (Double termination): 400m (1312 feet) maximum; 0.3m (1 foot) maximum stub lengths
Link Power	Supports 24VAC or 24VDC link power with optional external components; reference designs provided for both switching and linear power supplies Application Output Current: up to 100mA @ 3.3V DC
Coupling Options	Direct Connect (for applications within a single enclosure) Non-isolated/Grounded Non-isolated/Floating Transformer-isolated (very high common mode and interference immunity)
EMI	Designed to comply with FCC Part 15 Level A and EN55022 Level A
ESD	Designed to comply with 61000-4-2 Level 4 (contact - 8kV; air - 15kV)
ESD Human Body Model (MIL-STD-883) (for pins NET_A and NET_B)	8kV
Radiated Electromagnetic Susceptibility	Designed to comply with 61000-4-3 Level 3 (10V/m)
Fast Transient/Burst Immunity	Designed to comply with 61000-4-4 Level 4 (2kV)
Surge Immunity	Designed to comply with 61000-4-5 Level 3 (2kV)
Conducted RF Immunity	Designed to comply with 61000-4-6 Level 3 (10Vrms)
Common Mode Range (0 – 60Hz)	277Vrms with Transformer-isolated coupling +/-40V with Non-isolated/Grounded coupling
I/O	4 digital I/Os and 1 digital input without a microcontroller (unhosted), 8mA drive, 5V tolerant for LEDs, digital I/O, and transistors
Pyxos Host Microcontroller Interface	SPI (Serial Peripheral Interface)
Package	20 Pin QFN 5mm x 5mm package
Operating Voltage	3.3V ±10%
Operating Temperature	-40°C to +85°C

Ordering Information

Echelon Product	Echelon Model Number
Pyxos FT Communication IC	11500R-300 (Dry Pack of Five Tubes) 11500R-5000 (Tape and Reel Package)
Pyxos FT Communication IC Samples (Qty 5)	11500R-ES
Pyxos FT Evaluation Kit	11000R-10-1P

Non-Echelon Product	Model Number
Network Isolation Coupling Transformer*	TMS80040CS
Switching Power Supply Transformer*	TMS60563CS

* Available from:

Transtek Magnetics
1900 W. Grant Road
Tuscon, AZ, USA 85745
(800) 378 0015

Copyright © 2007, Echelon Corporation. Echelon, LON, LonWorks, LonMark, LonBuilder, NodeBuilder, LonManager, LonTalk, LonUsers, LonPoint, Digital Home, Neuron, 3120, 3150, LNS, iLON, LonWorld, ShortStack, Panoramix, Panoramix Powered by Echelon, LonMaker, the Echelon logo, and the LonUsers logo are trademarks of Echelon Corporation registered in the United States and other countries. Pyxos, LonLink, LonResponse, LonSupport, LONews, Open Systems Alliance, OpenLDV, LonBridge, Powered by Echelon, LNS Powered by Echelon, LonWorks Powered by Echelon, Networked Energy Services Powered by Echelon, NES Powered by Echelon, and Thinking Inside the Box are trademarks of Echelon Corporation. Other trademarks belong to their respective holders.

DISCLAIMER

PYXOS FT CHIPS, NEURON CHIPS, FREE TOPOLOGY TWISTED PAIR TRANSCEIVER MODULES, AND OTHER OEM PRODUCTS WERE NOT DESIGNED FOR USE IN EQUIPMENT OR SYSTEMS INTENDED FOR SURGICAL IMPLANT INTO THE BODY, OR OTHER APPLICATIONS INTENDED TO SUPPORT OR SUSTAIN LIFE, FOR USE IN FLIGHT CONTROL OR ENGINE CONTROL EQUIPMENT WITHIN AN AIRCRAFT, OR FOR ANY OTHER APPLICATION THAT INVOLVES DANGER TO HUMAN HEALTH OR SAFETY OR A RISK OF PROPERTY DAMAGE. ECHELON ASSUMES NO RESPONSIBILITY OR LIABILITY FOR USE OF THE PYXOS FT CHIPS, NEURON CHIPS OR FREE TOPOLOGY TWISTED PAIR TRANSCEIVER MODULES IN SUCH APPLICATIONS. ECHELON SPECIFICALLY DISCLAIMS ANY IMPLIED WARRANTY OF MERCHANTABILITY OR FITNESS FOR A PARTICULAR PURPOSE. ECHELON SHALL NOT BE LIABLE TO ANY USER OF THE PYXOS FT CHIPS, NEURON CHIPS, OR FREE TOPOLOGY TWISTED PAIR TRANSCEIVER MODULES FOR ANY LOST PROFITS OR OTHER SPECIAL, CONSEQUENTIAL, INDIRECT, PUNITIVE OR INCIDENTAL DAMAGES, HOWEVER CAUSED ON ANY THEORY OF LIABILITY, ARISING IN ANY WAY OUT OF THE DEVELOPMENT OR DISTRIBUTION OF APPLICATIONS OR SYSTEMS USING SUCH PRODUCTS.

003-0406-01B



www.echelon.com