

PL 3120® and PL 3150® Power Line Smart Transceivers Models 15310-1000, 15320-960, 15311R-1000, and 15321R-960

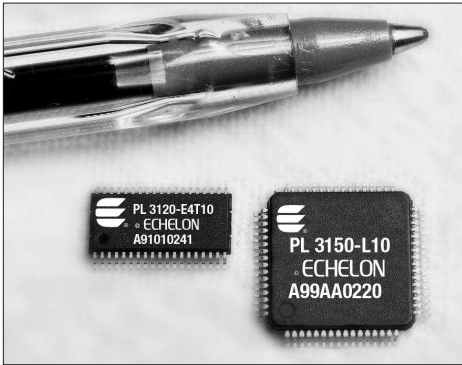

Overview

The PL 3120 and PL 3150 Power Line Smart Transceivers integrate a Neuron processor core with a power line transceiver, making them ideal for appliance, audio/video, lighting, heating/cooling, security, metering, and irrigation applications. Essentially a system-on-a-chip, the Power Line Smart Transceivers feature a highly reliable narrow-band power line transceiver, an 8-bit Neuron processor core for running applications and managing network communications, a choice of on-board or external memory, and an extremely small form factor – all at a price that is compelling for even the most cost-sensitive consumer product applications.

A Global Product

Compliant with FCC, Industry Canada, Japan MPT, and European CENELEC EN50065-1 regulations, the PL 3120 and PL 3150 Power Line Smart Transceivers can be used in applications worldwide.

The Power Line Smart Transceivers implement the CENELEC access protocol, which can be enabled or disabled by the user. This eliminates the need for users to develop the complex timing and access algorithms mandated under CENELEC EN50065-1. Additionally, the Power Line Smart Transceivers can operate in either the CENELEC utility (A-band) or general signaling (C-band) bands, eliminating the need to stock multiple parts for different applications.

Unmatched Performance

Intermittent noise sources, impedance changes, and attenuation make the power line a hostile signaling environment. The PL 3120 and PL 3150 Power Line Smart Transceivers incorporate a variety of technical innovations to insure reliable operation:

- ▼ Combines an ANSI-709.2 compliant Power Line Transceiver with an ANSI 709.1 compliant Neuron® 3120 or Neuron 3150 processor core
- ▼ Designed to comply with FCC, Industry Canada, Japan MPT, and European CENELEC EN 50065-1 power line communications regulations
- ▼ Supports CENELEC A-band and C-band operation
- ▼ Dual carrier frequency mode and digital signal processing
- ▼ 4K Bytes of embedded EEPROM for application code and configuration data on the PL 3120 Power Line Smart Transceiver and 0.5K Bytes of embedded EEPROM for configuration data on the PL 3150 Power Line Smart Transceiver
- ▼ Interface for external memory for applications with larger memory requirements (PL 3150 Power Line Smart Transceiver only)
- ▼ 2K Bytes of embedded RAM for buffering network data and network variables
- ▼ Full duplex hardware UART and SPI serial interfaces
- ▼ 12 I/O pins with 38 programmable standard I/O modes to minimize external interface circuitry
- ▼ -40 to +85°C operating temperature range

- Unique dual carrier frequency feature automatically selects an alternate secondary communication frequency should the primary frequency be blocked by noise;
- Highly efficient, patented, low-overhead forward error correction (FEC) algorithm to overcome errors induced by noise;
- Sophisticated digital signal processing, noise cancellation, and distortion correction algorithms. These features correct for a wide variety of signaling impediments, including impulsive noise, continuous tone noise, and phase distortion;
- High output, low distortion external amplifier design that can deliver 1Ap-p into low impedance loads, eliminating the need for expensive phase couplers in typical residential applications.

The combination of these special features enable the Power Line Smart Transceivers to operate reliably in the presence of consumer electronics, power line intercoms, motor noise, electronic ballasts, dimmers, and other typical sources of interference. The Power Line Smart Transceivers can communicate over virtually any AC or DC power mains, as well as unpowered twisted pair, by way of a low-cost, external coupling circuit.

The PL 3120 Power Line Smart Transceiver is targeted at very low cost designs that require up to 4K Bytes of application code, and an ultra-compact 38 TSSOP package. The chip includes 4K

Bytes of EEPROM and 2K Bytes of RAM. The Neuron system firmware and software application libraries are contained in on-chip ROM.

The PL 3150 Power Line Smart Transceiver is intended for applications that need to address up to 58K Bytes of external memory (16K Bytes is dedicated to the Neuron system firmware) using a 64 LQFP package. The chip includes 0.5K Bytes of EEPROM and 2K Bytes of RAM.

The PL 3120 and PL 3150 Power Line Smart Transceivers operate at either 6.5536MHz or 10.0MHz. The 6.5536MHz clock frequency enables the Power Line Smart Transceiver to communicate in the CENELEC A-band, which is used for metering and utility applications. The 10MHz clock frequency supports the CENELEC C-band, which is used for general purpose signaling and all non-utility related applications.

Application programs stored in the embedded EEPROM (PL 3120 Power Line Smart Transceiver) or in the external non-volatile memory (PL 3150 Power Line Smart Transceiver) may be updated over the power line network. This valuable feature enables products to be updated without physically accessing them, i.e., from a local PC with a power line interface or from a remote service center through an *i.LON*[®] Internet Server. The embedded EEPROM may be written up to 10,000 times with no data loss. Data stored in the EEPROM will be retained for at least ten years.

Inexpensive Power Supply

The PL 3120 and PL3150 Power Line Smart Transceivers use +8.5 to +18VDC and +5VDC power supplies and support very low receive mode current consumption. The wide power supply range and very low receive power requirements allow the use of inexpensive power supplies.

Additionally, the Power Line Smart Transceivers incorporate a power management feature that constantly monitors the status of the device's power supply. If during transmission the power supply voltage falls to a level that is insufficient to ensure reliable signaling, the transceiver stops transmitting until the power supply voltage rises to an acceptable level. This unique feature allows the use of a power supply with one-third the current capacity otherwise required. The net result is a reduction in the size, cost, and thermal dissipation of the power supply. Power management is especially useful for high volume, low-cost consumer products such as electrical switches, motion detectors, outlets, light sensors, and dimmers.

Flexible I/O, Simple Configuration

The PL 3120 and PL 3150 Power Line Smart Transceivers provide 12 I/O pins which can be configured to operate in one or more of 38 predefined standard input/output modes. Combining a wide range of I/O models with two on-board timer/counters enables the PL 3120 and PL 3150 Power Line Smart Transceivers to interface with application circuits using minimal external logic or software development. The Power Line Smart Transceivers also feature a full duplex hardware UART supporting baud rates of up to 115kbps, and an SPI interface that operates up to 625kbps.

External Components

Only a small number of inexpensive external components are required to create a complete Power Line Smart Transceiver-based device (see the PL 3120 / PL 3150 Power Line Smart Transceiver Block Diagram). These components include:

- Discrete interface circuitry comprised of roughly fifty components, primarily resistors and capacitors. This circuitry provides "front-end" filtering for the on-chip A/D, and implements the power amplifier that drives the on-chip D/A transmit signal onto the power line. Echelon offers a comprehensive Power Line Development Support Kit* (DSK) with which customers can implement this interface circuitry. Contact your salesperson for details about purchasing a PL DSK.
- Coupling circuit consisting of approximately ten components, mainly capacitors and inductors, which acts as a simple high-pass filter located between the Power Line Smart Transceiver and the power mains. This circuitry provides surge and line transient protection in addition to blocking the low frequency, 50Hz/60Hz AC mains signal. Detailed schematics are provided in the *PL 3120 / PL 3150 Power Line Smart Transceiver Data Book*.
- The new RoHS compliant Revision B Power Line Smart Transceivers eliminate the need for an external inverter, thereby reducing the cost of external components. Circuits without an external inverter can only be used with Revision B parts (15311R-1000 PL 3120 Power Line Smart Transceiver and 15321R-960 PL 3150 Power Line Smart Transceiver).

*Echelon Corporation has developed and patented certain methods of implementing circuitry external to the PL 3120 and PL 3150 Power Line Smart Transceiver chips. These patents are licensed pursuant to the Echelon Power Line Smart Transceiver Development Support Kit License Agreement.

PL 3120 / PL 3150 Power Line Smart Transceiver Block Diagram

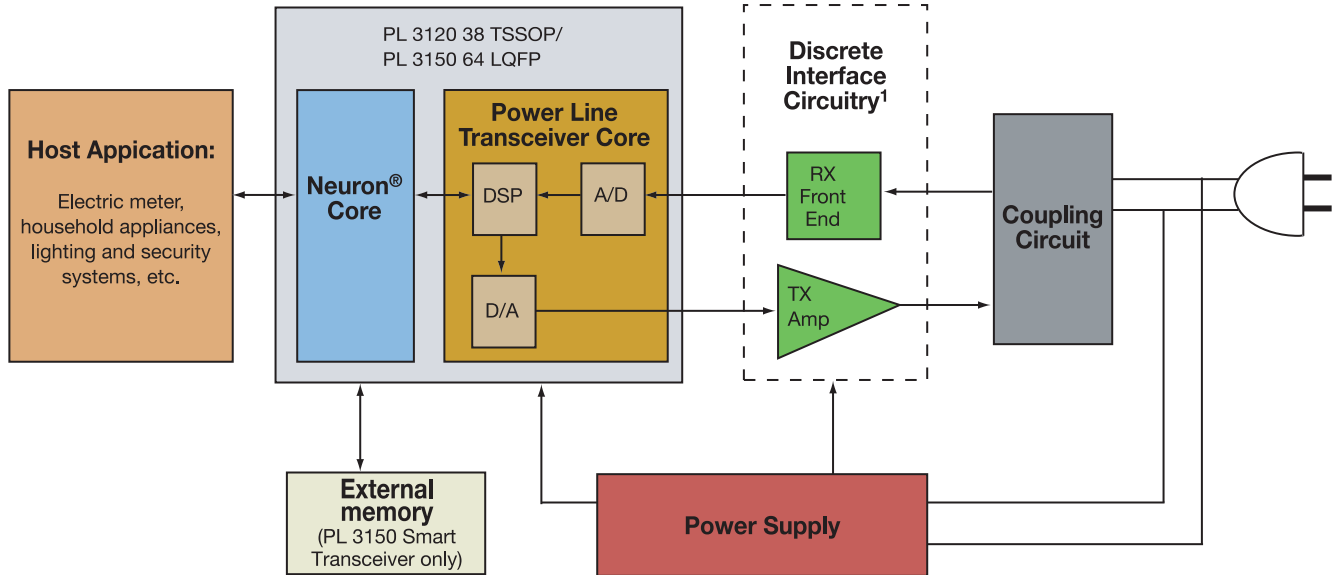

General Specifications

Function	Description
Emissions compliance	Designed to be compliant with FCC, Industry Canada, Japan MPT, and CENELEC EN50065-1 specification for low-voltage signaling
Bit rate	5.4kbps raw bit rate in CENELEC C-band and 3.6kbps in CENELEC A-band
Communication technique	Dual Frequency BPSK with DSP-enhanced receiver
Carrier frequencies	132kHz (primary) and 115kHz (secondary) in CENELEC C-band and 86kHz (primary) and 75kHz (secondary) in CENELEC A-band
RoHS Compliance	Models 15311R-1000 and 15321R-960 are designed to be compliant with European Directive 2002/95/EC on Restriction of Hazardous Substances (RoHS) in electrical and electronic equipment.

PL 3120 Power Line Smart Transceiver Pinout Diagram

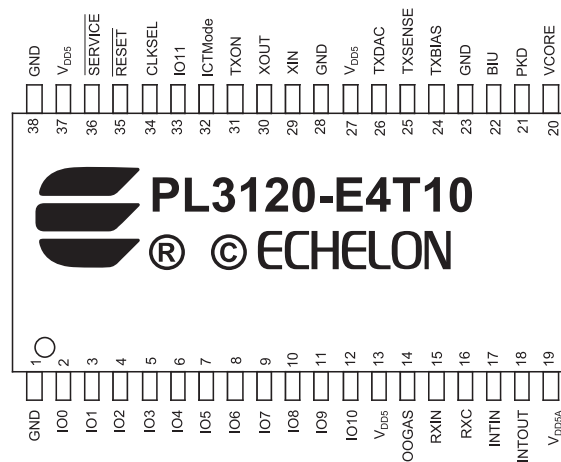

38 Pin TSSOP

NOTE:

¹ The schematic, bill of materials, and layout plots for the Discrete Interface Circuitry are provided in the PL DSK Power Line Smart Transceiver Development Support Kit.

PL 3150 Power Line Smart Transceiver Pinout Diagram

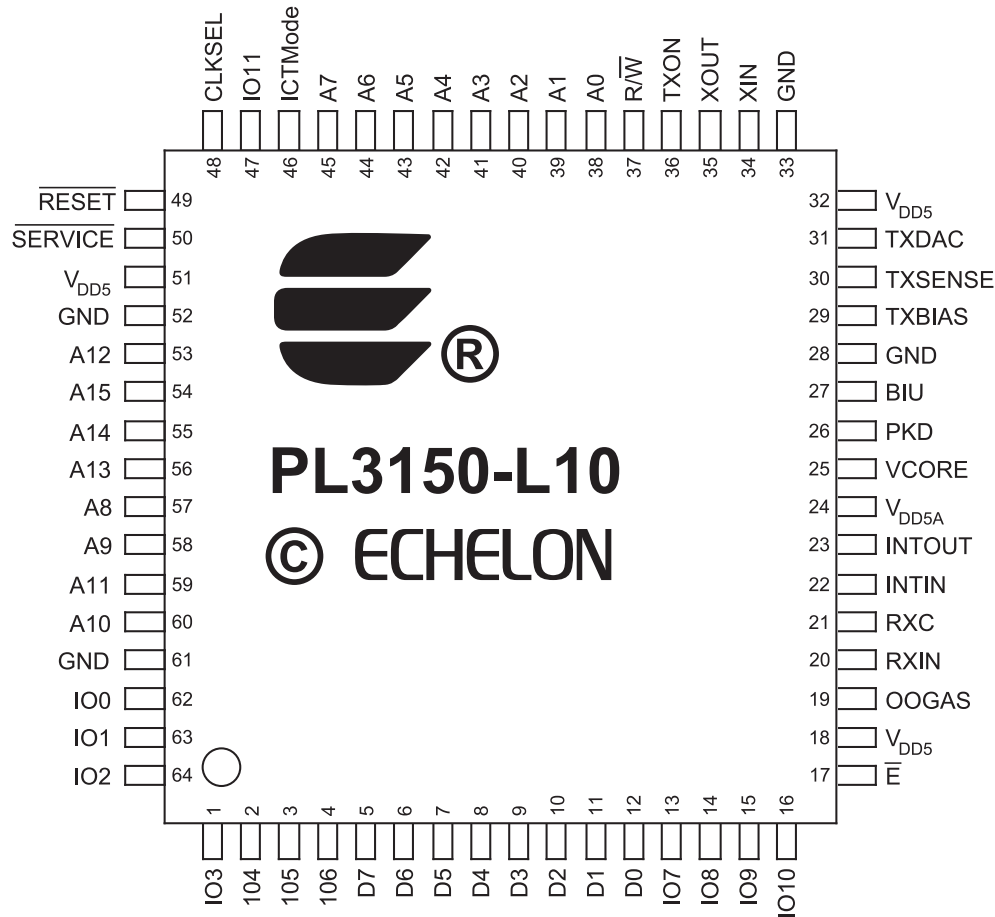

64 Pin LQFP

PL 3120 and PL 3150 Power Line Smart Transceiver Pin Descriptions

Pin Name	Type	Pin Functions	PL 3120-E4T10 38 TSSOP Pin No.	PL 3150-L10 64 LQFP Pin No.
XIN	Input	Oscillator connection or external clock input.	29	34
XOUT	Output	Oscillator connection.	30	35
RESET	Digital I/O (Built-in Pull-up)	Reset pin (active LOW). Note: The maximum external capacitance is 1000pF.	35	49
SERVICE	Digital I/O (Built-in Configurable Pull-up)	Service pin (active LOW).	36	50
CLKSEL	Digital Input	Tie to V_{DD5} .	34	48
IO0-IO3	Digital I/O	Large current-sink capacity (20mA). General purpose I/O. The output of timer/counter 1 may be routed to IO0. The output of timer/counter 2 may be routed to IO1.	2, 3, 4, 5	62, 63, 64, 1
IO4-IO7, IO11	Digital I/O (Built-in Configurable Pull-up)	General purpose I/O. The input of timer/counter 1 may be one of IO4-IO7. The input of timer/counter 2 is IO4.	6, 7, 8, 9, 33	2, 3, 4, 13, 47
IO8	Digital I/O	General purpose I/O. UART RX. SPI slave clock input. SPI master clock output.	10	14
IO9	Digital I/O	General purpose I/O. SPI slave data output. SPI master data input.	11	15
IO10	Digital I/O	General purpose I/O. SPI slave data input. SPI master data output.	12	16
D0-D7	I/O	Bi-directional data bus	N/A	12, 11, 10, 9, 8, 7, 6, 5
R/W	Output	Read/write control output for external memory	N/A	37

Pin Name	Type	Pin Functions	PL 3120-E4T10 38 TSSOP Pin No.	PL 3150-L10 64 LQFP Pin No.
\overline{E}	Output	Enable clock control output for external memory	N/A	17
A0-A15	Output	Memory address output port	N/A	38, 39, 40, 41, 42, 43, 44, 45, 57, 58, 60, 59, 53, 56, 55, 54
V _{DD5}	Power	Power input (5V nom). All V _{DD5} pins must be connected together externally.	13, 27, 37	18, 32, 51
V _{DD5A}	Power	Power input (5V nom). Supplies on-chip analog circuitry.	19	24
GND	Power	Power input (0V, GND). All GND pins must be connected together externally.	1, 23, 28, 38	28, 33, 52, 61
ICTMode	Digital Input	In-circuit test mode control. Driving ICTMode high and RESET low will place all outputs in high impedance mode for in-circuit test. Tie to GND for normal operation.	32	46
PKD	Digital Output	Packet Detect LED driver.	21	26
BIU	Digital Output	Band in Use LED driver.	22	27
RXIN	Analog Input	Receiver input.	15	20
INTIN,INTOUT	Analog I/O	Integrator input and output.	17, 18	22, 23
RXC	Analog Input	Receive signal.	16	21
OOGAS	Analog Input	Comparator to detect when energy storage power supply lacks sufficient energy to transmit a packet. Tie to V _{CORE} if not used.	14	19
V _{CORE}	Power	Output of internal 1.8V regulator. Requires 0.1 μ F external capacitor.	20	25
TXON	Digital Output	High when transmitting. Used to drive LED to show packet transmission.	31	36
TXDAC	Analog Output	Transmit waveform DAC output.	26	31
TXSENSE	Analog Input	Transmit amplifier sense feedback.	25	30
TXBIAS	Analog Output	Transmit amplifier bias generator.	24	29

Recommended Operating Conditions

Symbol	Parameter	Min.	Typ.	Max.	Unit
V _{DD5}	V _{DD5} Supply Voltage	4.75	5.00	5.25	V
V _{DD5A}	V _{DD5A} Supply Voltage	4.60	5.00	5.25	V
T _A	Ambient Temperature	-40	25	85	°C
F _{A-band}	XIN Frequency for A-band Operation (6.5536MHz \pm 200ppm)	6.5523	6.5536	6.5549	MHz
F _{C-band}	XIN Frequency for C-band Operation (10.0000MHz \pm 200ppm)	9.9980	10.0000	10.0020	MHz

Electrical Characteristics (over recommended operating conditions)

Symbol	Parameter	Min.	Typ.	Max.	Unit
V _{IL}	Digital Input Low-Level Voltage			0.8	V
V _{IH}	Digital Input High-Level Voltage	2.0			V
V _{OL}	Digital Output Low-Level Voltage I _{out} < 20 μ A IO4-IO11, A0-A14, D0-D7, R/ \overline{W} , \overline{E} (I _{OL} = 1.4mA) IO0-IO3, SERVICE, RESET (I _{OL} = 20mA) IO0-IO3, SERVICE, RESET (I _{OL} = 10mA) PKD, BIU, TXON (I _{OL} = 12mA)			0.1 0.4 0.8 0.4 0.5	V
V _{OH}	Digital Output High-Level Voltage I _{out} < 20 μ A IO4-IO11, A0-A14, D0-D7, R/ \overline{W} , \overline{E} (I _{OH} = -1.4mA) IO0-IO3, SERVICE, RESET (I _{OH} = -1.4mA) PKD, BIU, TXON (I _{OH} = -12mA)		V _{DD5} -0.1 V _{DD5} -0.5 V _{DD5} -0.4 V _{DD5} -0.5		V
V _{hys}	Digital Input Hysteresis	175			mV
I _{in}	Input Current (Excluding Pull-ups) ²	-10		10	μ A

NOTE:

² IO4-IO7 and SERVICE pins have configurable pull-ups. The RESET pin has a permanent pull-up.

Symbol	Parameter	Min.	Typ.	Max.	Unit
I_{pu}	Pull-up Source Current ($V_{out}=0$, $Output=High-Z$) ²	30		300	μA
I_{DD}	PL 3120 Power Line Smart Transceiver $V_{DD5} + V_{DD5A}$ Supply Current (not including I/O or internal pull-up current)		9	13	mA
I_{DD}	PL 3150 Power Line Smart Transceiver $V_{DD5} + V_{DD5A}$ Supply Current (not including I/O or internal pull-up current)		12	16	mA
V_{LVI}	V_{DD5} LVI Trip Point	4.0		4.45	V

External Memory Interface Timing - PL 3150 Power Line Smart Transceiver (over recommended operating conditions) See Figures 1 to 6 for detailed measurement information

Parameter	Description	Min.	Max.	Unit
t_{cyc}	Memory Cycle Time (Input Clock 10MHz, +/- 200ppm)	199.96	200.04	ns
t_{cyc}	Memory Cycle Time (Input Clock 6.5536MHz, +/- 200ppm)	305.12	305.79	ns
PW_{EH}	Pulse Width, \bar{E} High ³	$t_{cyc}/2-5$	$t_{cyc}/2+5$	ns
PW_{EL}	Pulse Width, \bar{E} Low	$t_{cyc}/2-5$	$t_{cyc}/2+5$	ns
t_{AD}	Delay, \bar{E} High to Address Valid		40	ns
t_{AH}	Address Hold Time After \bar{E} High	10		ns
t_{RD}	Delay, \bar{E} High to R/ \bar{W} Valid Read		40	ns
t_{RH}	R/ \bar{W} Hold Time Read After \bar{E} High	10		ns
t_{WR}	Delay, \bar{E} High to R/ \bar{W} Valid Write		40	ns
t_{WH}	R/ \bar{W} Hold Time Write After \bar{E} High	10		ns
t_{DSR}	Read Data Setup Time to \bar{E} High	20		ns
t_{DHR}	Data Hold Time Read After \bar{E} High	0		ns
t_{DHW}	Data Hold Time Write After \bar{E} High ⁴	10		ns
t_{DDW}	Delay, \bar{E} Low to Data Valid		15	ns
t_{acc}^5	External Read Access Time ($t_{acc} = t_{cyc} - t_{AD} - t_{DSR}$) at 10MHz Input Clock		140	ns

Recommended Operating Conditions for Power Line Smart Transceiver Discrete Interface Circuitry¹

Symbol	Parameter	Min.	Typ.	Max.	Unit
V_{ARX}	V_A Supply Voltage - Receive Mode ⁶	8.5	12.0	18.0	V
V_{ATX}	V_A Supply Voltage - Transmit Mode ⁶	10.8	12.0	18.0	V
T_A	Ambient Temperature	-40	25	85	°C

Electrical Characteristics of Power Line Smart Transceiver Discrete Interface Circuitry¹ (over recommended operating conditions)

Symbol	Parameter	Min.	Typ.	Max.	Unit
I_{ARX}	V_A Supply Current - Receive Mode		350	500	μA
I_{ATX}	V_A Supply Current - Transmit Mode		120	250	mA
V_{OTX}	Transmit Output Voltage		7		Vp-p
I_{TXLIM}	Transmit Output Current Limit		1.0		Ap-p
Z_{INRX}	Input Impedance - Receive Mode (with recommended RXCOMP inductor)		500		Ω
Z_{OTX}	Output Impedance - Transmit Mode		0.9		Ω
V_{PMU}	Power Management - Upper V_A Threshold	11.2	12.1	13.0	V
V_{PML}	Power Management - Lower V_A Threshold	7.3	7.9	8.6	V

NOTES:

³ $t_{cyc} = 2/f$ where f is the input clock (XIN) frequency (10 or 6.5536MHz).

⁴ The data hold parameter, t_{DHW} , is measured to disable levels shown in Figure 6, rather than to the traditional data invalid levels.

⁵ This parameter considers only the memory read access time from address to data. This does not allow for chip enable decode. See *Neuron 3150 Chip External Memory Interface Engineering Bulletin* (005-0013-01D) for memory decode timing analysis examples.

⁶ Minimum value can be 8.5V under certain conditions (refer to Data Book for details).

Maximum value must also satisfy the following: $V_{ATXAVE} < (150 - T_{AMAX}) / (8 * D_{MAX})$;

Where: V_{ATXAVE} = Average V_A supply voltage while transmitting

T_{AMAX} = Maximum ambient temperature (°C)

D_{MAX} = Maximum transmit duty cycle of the device (expressed as decimal number)

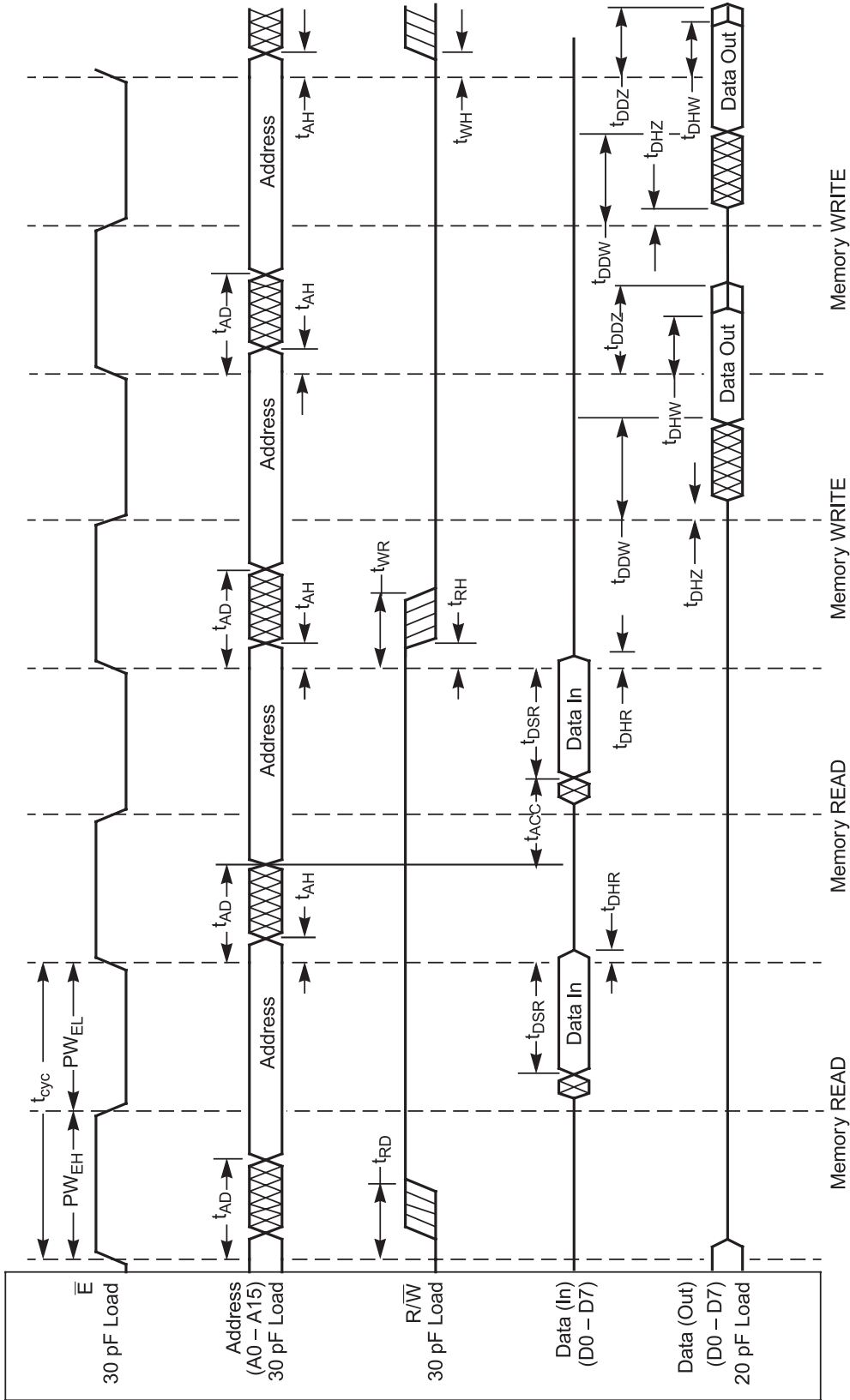
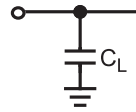

Figure 1. External Memory Interface Timing Diagram

TEST SIGNAL



$C_L = 30 \text{ pF}$ for \bar{E} , A, R/\bar{W} ; 20 pF for D

Figure 2. Signal Loading for Timing Specifications

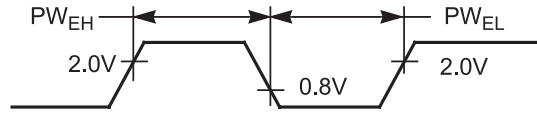

Figure 3. Test Point Levels for E Pulse Width Measurements

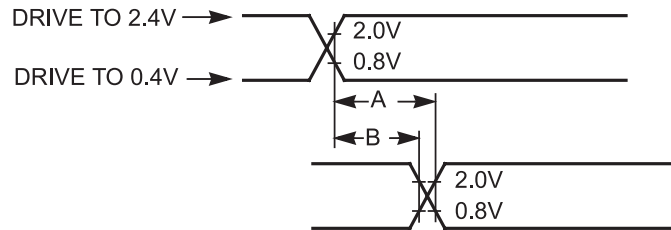

Figure 4. Drive Levels and Test Point Levels for Timing Specifications Unless Otherwise Specified

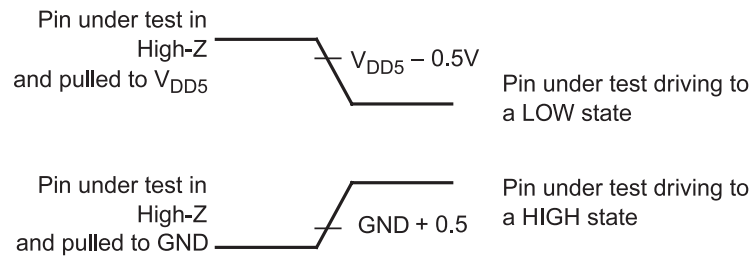
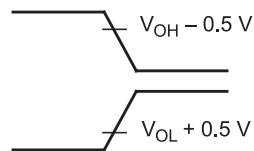

Figure 5. Test Point Levels for High Impedance-to-Drive Time Measurements



V_{OH} – Measured high output drive level
 V_{OL} – Measured low output drive level

Figure 6. Test Point Levels for Driven-to-High Impedance Time Measurements

Absolute Maximum Ratings⁷

Ambient operating temperature	-40 to 85°C
Storage temperature	-55 to 125°C
Voltage on V _{DD5} and V _{DD5A} pins with respect to GND	-0.3 to 6.0V
Voltage on each pin with respect to GND ⁸	-0.3 to (V _{DD5} + 0.3V)
Voltage on TXBIAS, TXSENSE, OOGAS pins	-0.3 to 1.89V
Maximum voltage on V _{CORE} pin with respect to GND	1.89V
V _{DD5} , V _{DD5A} , or GND current per pin	±50mA
Input clamp current, I _{IK} ⁸ (V _I <0 or V _I >V _{DD5})	±10mA
Output clamp current, I _{OK} ⁸ (V _I <0 or V _I >V _{DD5})	±10mA
Output current per pin ⁵	±25mA
Power dissipation	250mW
Reflow soldering temperature profile	Refer to Joint Industry Standard document <i>IPC/JEDEC J-STD-020C</i> (July 2004)
Reflow soldering temperature	235°C (Models 15310-1000 and 15320-960) 260°C (Models 15311R-1000 and 15321R-960)

Recommended Pad Layout for PL 3120-E4T10 Power Line Smart Transceiver (38 TSSOP)

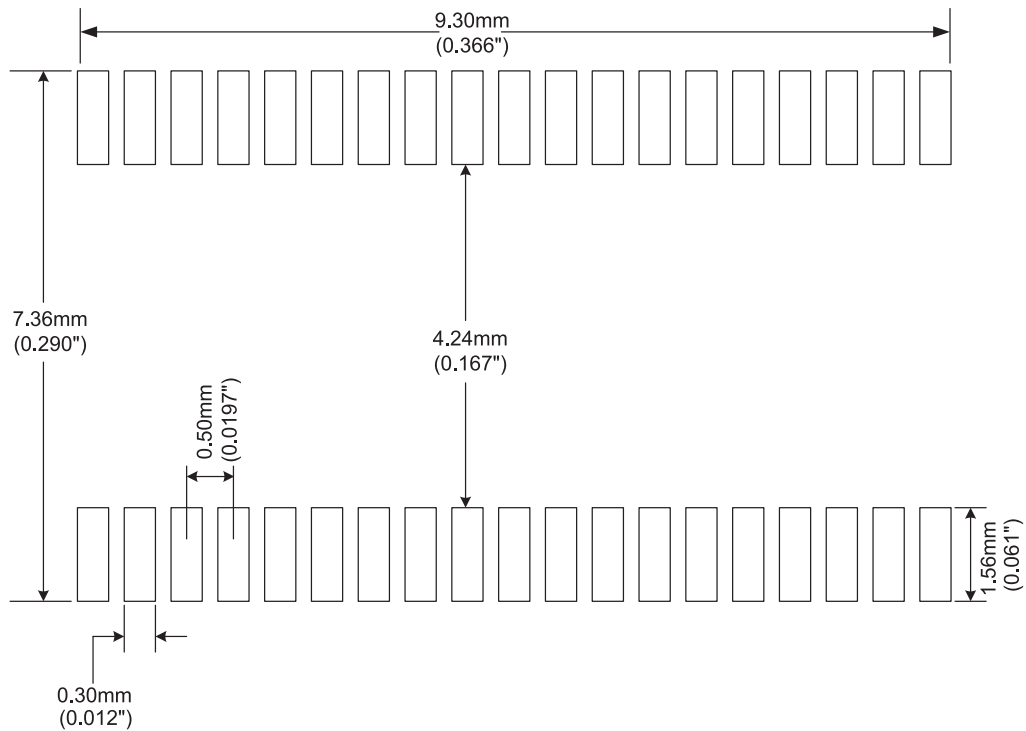

NOTES:

⁷ Stresses beyond the "Absolute Maximum Ratings" may cause permanent damage to the device. Functional operation under these conditions is not implied.

⁸ Applies to all pins except V_{DD5}, V_{DD5A}, V_{CORE}, TXBIAS, TXSENSE, and OOGAS.

Recommended Pad Layout for PL 3150-L10 Power Line Smart Transceiver (64 LQFP)

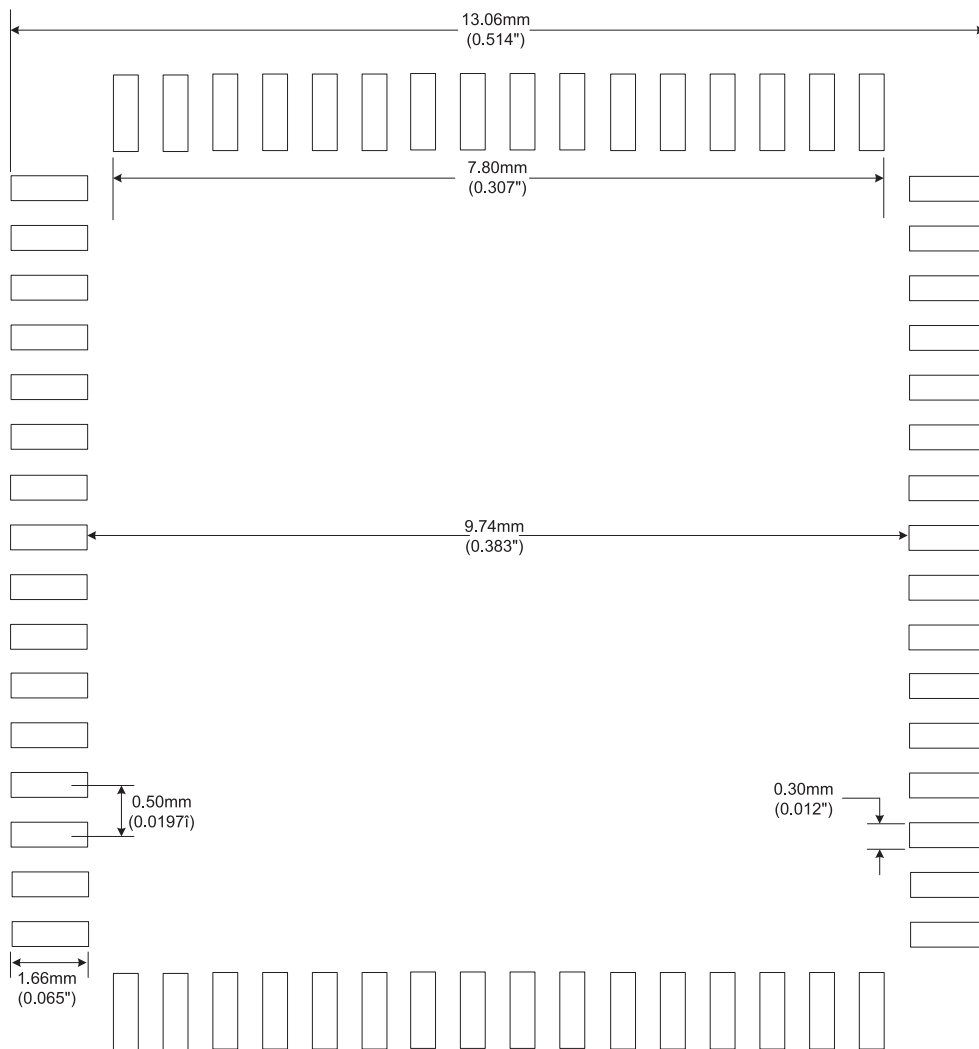

PL 3120-E4T10 Power Line Smart Transceiver Package Diagram

38 TSSOP

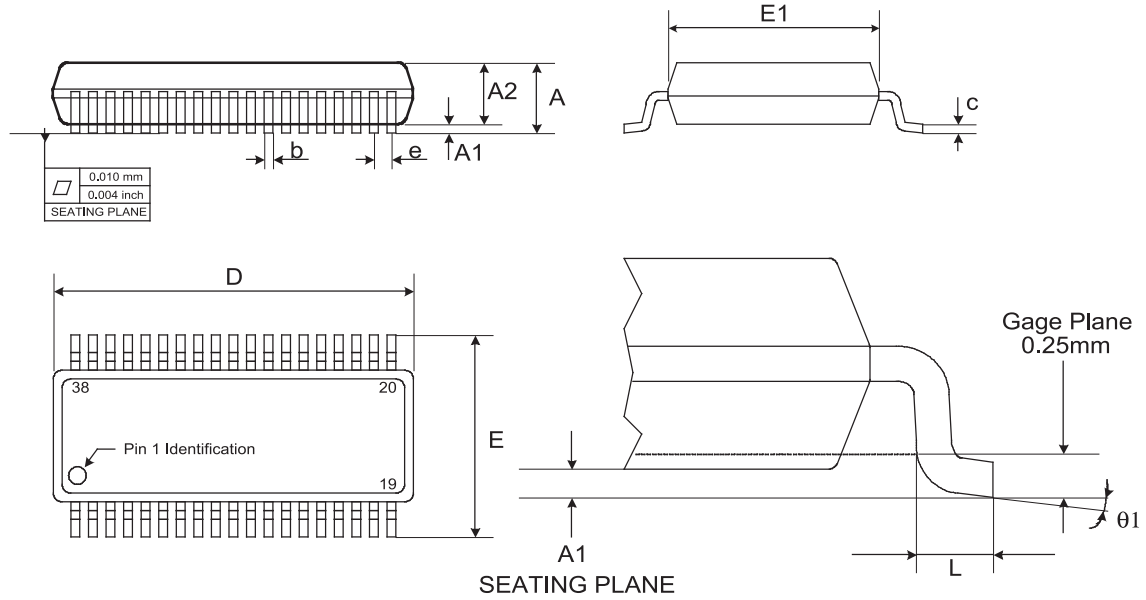

Symbol	mm (prevailing dimensions)			inch		
	Min.	Nom.	Max.	Min.	Nom.	Max.
A	-	-	1.20	-	-	0.047
A1	0.05	-	0.15	0.002	-	0.006
A2	0.80	1.00	1.05	0.031	0.039	0.041
b	0.17	-	0.27	0.0067	-	0.011
c	0.09	-	0.20	0.0035	-	0.0079
D	9.60	9.70	9.80	0.378	0.381	0.385
E	6.40 BSC			0.252 BSC		
e	0.50 BSC			0.0197 BSC		
E1	4.30	4.40	4.50	0.169	0.173	0.177
L	0.45	0.60	0.75	0.0177	0.023	0.030
$\theta 1$	0°	-	8°	0°	-	8°

PL 3150-L10 Power Line Smart Transceiver Package Diagram

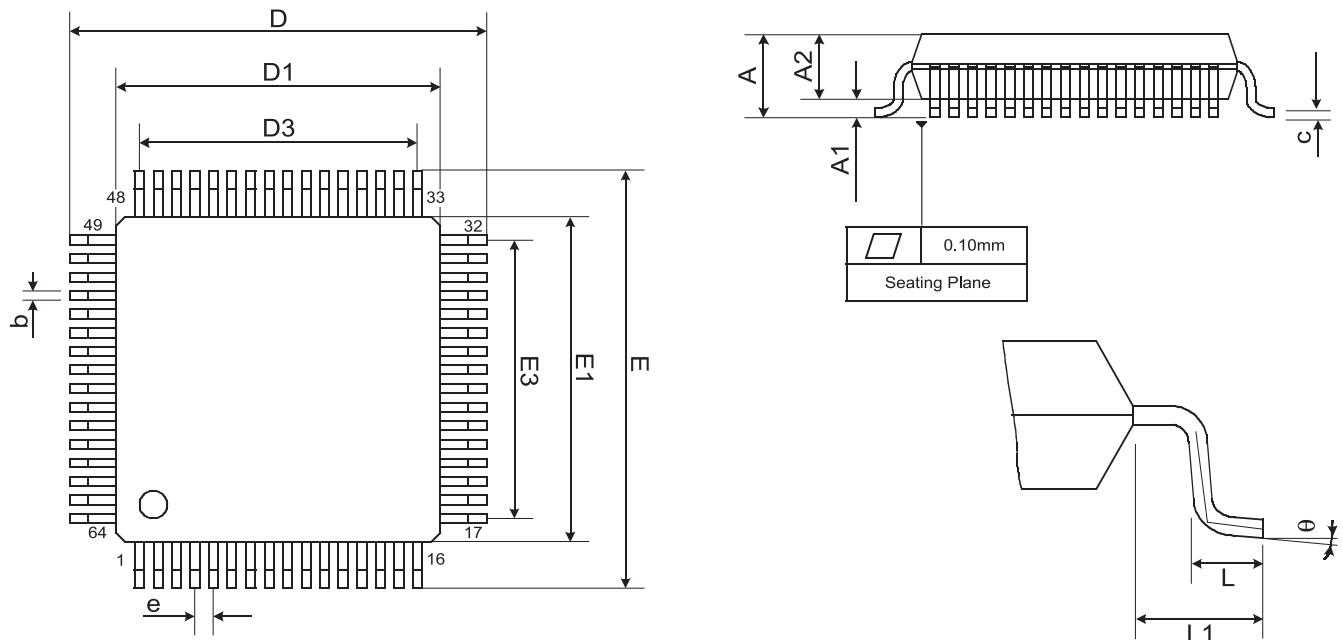

Symbol	mm (prevailing dimensions)			inch		
	Min.	Nom.	Max.	Min.	Nom.	Max.
A	-	-	1.60	-	-	0.063
A1	0.05	-	0.15	0.002	-	0.006
A2	1.35	1.40	1.45	0.053	0.055	0.057
b	0.17	0.22	0.27	0.007	0.009	0.011
c	0.09	0.16	0.20	0.0035	0.0063	0.0079
D	12.00 BSC			0.472 BSC		
D1	10.00 BSC			0.394 BSC		
D3	7.50 BSC			0.295 BSC		
e	0.50 BSC			0.0197 BSC		
E	12.00 BSC			0.472 BSC		
E1	10.00 BSC			0.394 BSC		
E3	7.50 BSC			0.295 BSC		
L	0.45	0.60	0.75	0.0177	0.0236	0.0295
LI	1.00 REF			0.0394 REF		
θ	0°	3.5°	7°	0°	3.5°	7°

Ordering Information

Power Line Smart Transceiver IC Product Number	Model Number	RoHS Compliant	Maximum Input Clock	EEPROM	RAM	ROM	External Memory Interface	IC Package	PL DSK Development Support Kit Model Number
PL 3120-E4T10	15310-1000	No	10MHz	4K Bytes	2K Bytes	24K Bytes	No	38 TSSOP	17050R-21-27
PL 3150-L10	15320-960	No	10MHz	0.5K Bytes	2K Bytes	N/A	Yes	64 LQFP	17050R-21-27
PL 3120-E4T10	15311R-1000	Yes	10MHz	4K Bytes	2K Bytes	24K Bytes	No	38 TSSOP	17050R-21-27
PL 3150-L10	15321R-960	Yes	10MHz	0.5K Bytes	2K Bytes	N/A	Yes	64 LQFP	17050R-21-27

P L 3 1 2 0 - E 4 T 1 0

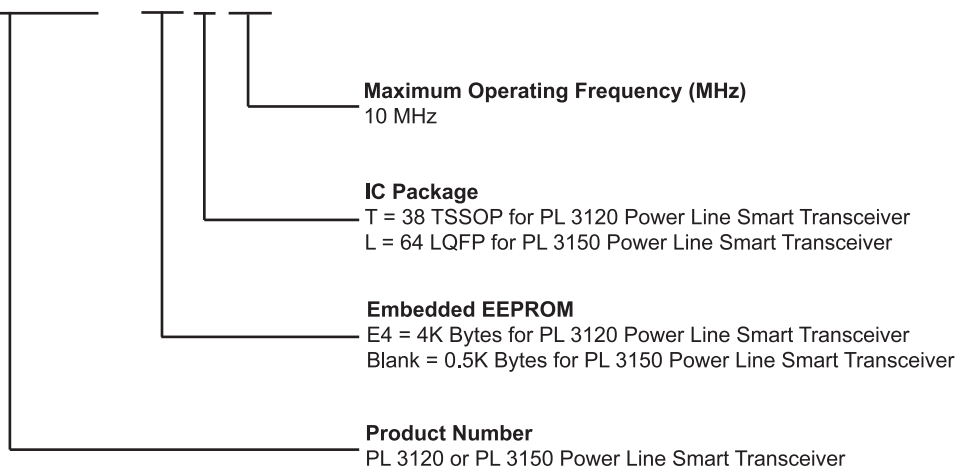

Documentation

The *PL 3120 / PL 3150 Power Line Smart Transceiver Data Book* may be downloaded from Echelon's web site or ordered through Echelon's literature fulfillment department.

Document

PL 3120 / PL 3150 Power Line Smart Transceiver Data Book

Echelon Part Number

005-0154-01

Copyright © 2005-2006, Echelon Corporation. Echelon, LON, LonWorks, LonMark, LonBuilder, NodeBuilder, LonManager, LonTalk, LonUsers, LonPoint, Digital Home, Neuron, 3120, 3150, LNS, iLON, LonWorld, ShortStack, LonMaker, Panoramix, Panoramix Powered by Echelon, the Echelon logo, and the LonUsers logo are trademarks of Echelon Corporation registered in the United States and other countries. LonLink, LonResponse, LonSupport, LonNews, Open Systems Alliance, OpenLDV, Powered by Echelon, LNS Powered by Echelon, LonWorks Powered by Echelon, Networked Energy Services Powered by Echelon, NES Powered by Echelon, and Digital Home Powered by Echelon are trademarks of Echelon Corporation. Other trademarks belong to their respective holders.

Disclaimer

Neuron Chips, Smart Transceivers, and other OEM Products were not designed for use in equipment or systems which involve danger to human health or safety or a risk of property damage and Echelon assumes no responsibility or liability for use of the Neuron Chips or Smart Transceivers in such applications. ECHELON MAKES AND YOU RECEIVE NO WARRANTIES OR CONDITIONS, EXPRESS, IMPLIED, STATUTORY OR IN ANY COMMUNICATION WITH YOU, AND ECHELON SPECIFICALLY DISCLAIMS ANY IMPLIED WARRANTY OF MERCHANTABILITY OR FITNESS FOR A PARTICULAR PURPOSE. 003-0378-01G



www.echelon.com