

# CONSTANT VOLTAGE & CONSTANT CURRENT CONTROLLER TJ1052

## FEATURES

- Constant Voltage and Constant Current Control
- Low Voltage Operation
- Precision Internal Component Count
- Current Sink Output Stage
- Easy Compensation
- Low AC Mains Voltage Rejection
- Moisture Sensitivity Level 3

## APPLICATION

- Battery Chargers
- Adapters

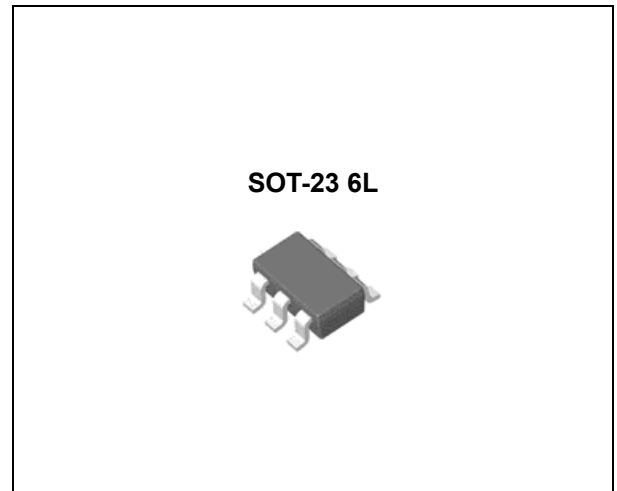

## ORDERING INFORMATION

Device	Package
TJ1052SF6	SOT-23 6L
TJ1052GSF6	

## DESCRIPTION

TJ1052 is a highly integrated solution for SMPS applications requiring constant voltage and constant current mode. TJ1052 integrates one voltage reference, two operational amplifiers (with one output - common collectors), and a current sensing circuit. The voltage reference combined with one operational amplifier makes it an ideal voltage controller, and the other low voltage reference combined with the other operational amplifier makes it an ideal current limiter for output low side current sensing. The current threshold is fixed and precise. The only external components are :

- A resistor bridge to be connected to the output of the power supply (adaptor, battery charger) to set the voltage regulation by dividing the desired output voltage to match the internal voltage reference value.
- A sense resistor having a value and allowable dissipation power which need to be chosen according to the internal voltage threshold.

TJ1052 is ideal for space shrunk applications such as adapters and battery chargers.

## Absolute Maximum Ratings

( $T_A = 25^\circ\text{C}$ , unless otherwise specified)

CHARACTERISTIC	SYMBOL	MIN.	MAX.	UNIT
DC Supply Voltage	$V_{CC}$	-	20	V
Input Voltage	$V_{IN}$	-0.3	$V_{CC}$	V
Operating Free Air Temperature Range	$T_{OPR}$	0	85	$^\circ\text{C}$
Maximum Junction Temperature	$T_J$	-	150	$^\circ\text{C}$

## Operating Conditions ( $T_A=25^\circ\text{C}$ )

CHARACTERISTIC	SYMBOL	MIN.	MAX.	UNIT
DC Supply Voltage	$V_{CC}$	2.5	18	V

# CONSTANT VOLTAGE & CONSTANT CURRENT CONTROLLER TJ1052

## Ordering Information

Package	Order No.	Package Marking	Supplied As	Status
SOT-23 6L	TJ1052SF6	TJ1052	Reel	Contact us
SOT-23 6L	TJ1052GSF6	TJ1052	Reel	Contact us

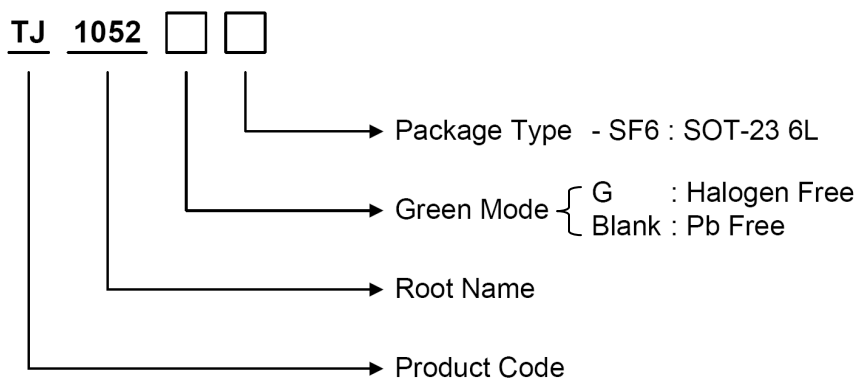

## PIN CONFIGURATION

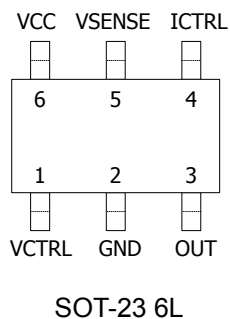

## PIN DESCRIPTION

Pin No.	SOT-23 6L	
	Name	Function
1	V <sub>CTRL</sub>	Analog Input
2	GND	Ground
3	OUT	Current Sink Output
4	I <sub>CTRL</sub>	Analog Input
5	V <sub>SENSE</sub>	Analog Input
6	V <sub>CC</sub>	Power Supply

# CONSTANT VOLTAGE & CONSTANT CURRENT CONTROLLER TJ1052

## ELECTRICAL CHARACTERISTICS

( $T_A=25^\circ\text{C}$  and  $V_{CC} = +5\text{V}$ , unless otherwise specified)

Symbol	Parameters	Condition	Min.	Typ.	Max.	Unit
<b>Total Current Consumption</b>						
$I_{CC}$	Total Supply Current - not taking the output sinking current into account	$T_A = 25^\circ\text{C}$ $0 < T_A < 85^\circ\text{C}$		1.1 1.2	2	mA
<b>Voltage Control Loop</b>						
$G_{MV}$	Transconduction Gain ( $V_{CTRL}$ ). Sink Current Only (Note 1)	$T_A = 25^\circ\text{C}$ $0 < T_A < 85^\circ\text{C}$	1	3.5 2.5		mA/mV
$V_{REF}$	Voltage Control Loop (Note 2)	$T_A = 25^\circ\text{C}$ $0 < T_A < 85^\circ\text{C}$	1.198 1.186	1.21	1.222 1.234	V
$I_{IBV}$	Input Bias Current ( $V_{CTRL}$ )	$T_A = 25^\circ\text{C}$ $0 < T_A < 85^\circ\text{C}$		200 300		nA
<b>Current Control Loop</b>						
$G_{MI}$	Transconduction Gain ( $I_{CTRL}$ ). Sink Current Only (Note 3)	$T_A = 25^\circ\text{C}$ $0 < T_A < 85^\circ\text{C}$	1.5	7		mA/mV
$V_{SENSE}$	Current Control Loop (Note 4)	$I_{out} = 2.5 \text{ mA}$ $0 < T_A < 85^\circ\text{C}$	196 192	200	204 208	mV
$I_{IBI}$	Current out of pin $I_{CTRL}$ at -200mV	$T_A = 25^\circ\text{C}$ $0 < T_A < 85^\circ\text{C}$		30 40		$\mu\text{A}$
<b>Output Stage</b>						
$V_{OL}$	Low output voltage at 10 mA sinking current	$T_A = 25^\circ\text{C}$ $0 < T_A < 85^\circ\text{C}$		200 500		mV
$I_{OS}$	Output Short Circuit Current. Output to $V_{CC}$ . Sink Current Only	$T_A = 25^\circ\text{C}$ $0 < T_A < 85^\circ\text{C}$		45 60	90	mA

Note 1. If the voltage on  $V_{CTRL}$  (the negative input of the amplifier) is higher than the positive amplifier input ( $V_{REF}=1.210\text{V}$ ), and it is increased by 1mV, the sinking current at the output will be increased by 3.5mA.

Note 2. The internal Voltage Reference is set at 1.210V (bandgap reference). The voltage control loop precision takes into account the cumulative effects of the internal voltage reference deviation as well as the input offset voltage of the trans-conductance operational amplifier. The internal Voltage Reference is fixed by bandgap, and trimmed to 0.5% accuracy at room temperature.

Note 3. When the positive input at  $I_{CTRL}$  is lower than -200mV, and the voltage is decreased by 1mV, the sinking current at the output will be increased by 7mA.

Note 4. The internal current sense threshold is set to -200mV. The current control loop precision takes into account the cumulative effects of the internal voltage reference deviation as well as the input offset voltage of the trans-conductance operational amplifier.

# CONSTANT VOLTAGE & CONSTANT CURRENT CONTROLLER TJ1052

## TYPICAL APPLICATION CIRCUIT

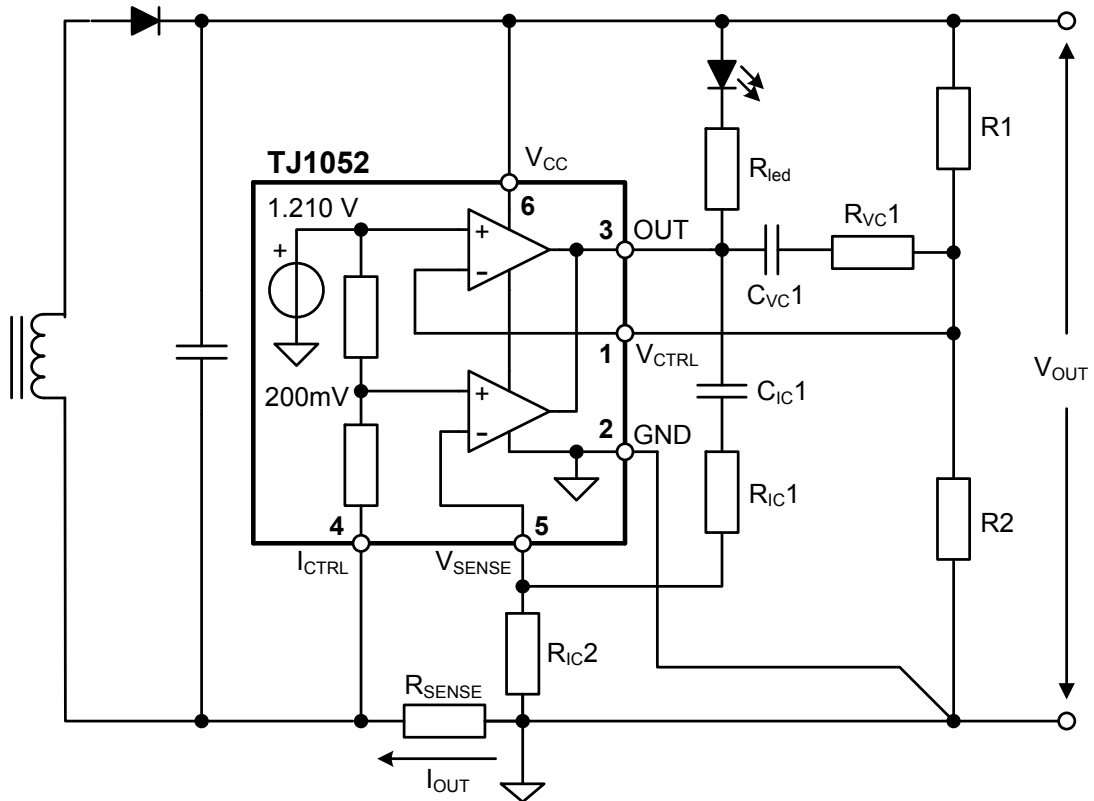

**Fig 1. Typical Adaptor or Battery Charger Application Using TJ1052**

In the above application schematic, the device is used on the secondary side of a flyback adaptor (or battery charger) to provide an accurate control of voltage and current. The above feedback loop is made with an optocoupler.