



**INVENTEK SYSTEMS**  
**ISM43362-M3G-L44**  
**Embedded Serial-to-Wi-Fi Modules**  
**eS-WiFi™**  
**802.11 b/g/n**  
**Data Sheet**



## Table of Contents

1	GENERAL DESCRIPTION .....	4
2	PART NUMBER DETAIL DESCRIPTION .....	5
2.1	Ordering Information .....	5
3	GENERAL FEATURES .....	5
3.1	Limitations .....	6
3.2	Regulatory Compliance .....	6
3.3	FCC and IC User’s Manual Statements: .....	7
4	COMPLEMENTARY DOCUMENTATION .....	10
4.1	Inventek Systems .....	10
5	SPECIFICATIONS .....	10
5.1	Module Architecture .....	10
5.2	External Antenna Connections .....	11
5.3	Mechanical Specifications .....	11
5.4	Environmental Specifications .....	12
6	HARDWARE ELECTRICAL SPECIFICATIONS .....	12
6.1.1	Absolute Maximum Ratings .....	12
6.1.2	Recommended Operating Ratings .....	12
7	Power Consumption .....	13
7.1.1	Estimated Power Consumption .....	13
7.1.2	Stop Mode .....	13
8	Pin out .....	14
8.1.1	Detailed Pin Description .....	15
8.1.2	Configuration Pins: .....	16
*	Requires a 10K ohm pull down .....	16
9	Firmware Upgrades during Development .....	16
10	Serial Host Interfaces Available .....	16
10.1	UART .....	16
10.1.1	Data Mode .....	17
10.1.2	Flow Control .....	17
10.1.3	Supported Baud Rates .....	17
10.1.4	Default Serial Configuration .....	17
10.2	SPI (Serial Peripheral Interface Bus) .....	17
10.2.1	SPI Communication Overview: .....	18
10.2.2	SPI Command Phase: .....	18
10.2.3	SPI Endian Example: .....	19
10.2.4	SPI Data Phase: .....	20
10.2.5	SPI Asynchronous Messages: .....	20
10.2.6	SPI AC Characteristics: .....	21
10.3	USB .....	21
10.4	GPIO .....	21

10.5	ADC's .....	21
11	Wi-Fi RF Specification .....	22
11.1.1	RF Specification.....	22
12	Antenna Patterns .....	23
12.1	External Antenna .....	23
12.2	PCB Etch Antenna Gain on the Evaluation Board .....	24
12.3	Farfield Directivity.....	25
13	On Board Processor .....	26
14	ISM43362-M3G-L44 FOOTPRINT .....	27
14.1	Module's dimensions top view (mm) .....	27
14.2	PCB recommended footprint top view (mm).....	27
15	Typical Application Circuit .....	28
15.1	Reference Schematic (EVB).....	29
15.2	USB to UART.....	30
15.3	Connecting Microcontroller to eS-WiFi UART .....	31
15.4	EXTERNAL FLASH FOR OVER THE AIR UPGRADE.....	31
15.5	JTAG and Reset Connections .....	32
15.6	eS-WiFi Programming Options .....	32
15.7	eS-WiFi USB Direct Connection Option.....	33
16	Product Compliance Considerations.....	33
17	Reflow Profile.....	34
18	Packaging Information.....	35
18.1	MSL Level / Storage Condition.....	35
18.2	Device baking requirements prior to assembly.....	36
	Module's Assembly Instructions .....	36
19	REVISION CONTROL .....	37
20	CONTACT INFORMATION.....	37

# 1 GENERAL DESCRIPTION

The Inventek ISM43362-M3G-L44 is an embedded (eS-WiFi™) wireless Internet Connectivity device. The Wi-Fi module hardware consists of an STM M3 Cortex host processor, integrated antenna (or optional external antenna) and Broadcom Wi-Fi device. The module provides UART, USB and SPI interfaces enabling connection to an embedded design. The Wi-Fi module requires no operating system and has a completely integrated TCP/IP Stack that only requires AT commands to establish connectivity for your wireless product, minimizing development time, testing routines and certification. The low cost, small foot print (14.5 mm x 30 mm) and ease of design-in make it ideal for a range of embedded applications. The module hardware can be used with Inventek's AT Command set or with Broadcom's WICED™ SDK.

## ***Summary of Key Features:***

- 802.11 b/g/n compliant based on Broadcom MAC/Baseband/Radio device.
- Fully contained TCP/IP stack minimizing host CPU requirements.
- Configurable using AT commands.
- Host interface: UART, SPI, or USB-HID.
- Network features: ICMP (Ping), ARP, DHCP, TCP, UDP.
- Low power operation (3.3V supply) with built-in low power modes.
- Secure Wi-Fi authentication WEP-128, WPA-PSK (TKIP), WPA2-PSK.
- Proven Interoperability ... Connects with other vendor's b/g/n Access Points in the Wireless LAN.
- Supported by Broadcom WICED™ SDK.

## ***Typical Applications:***

- PDA, Pocket PC, computing devices.
- Building automation and smart energy control.
- Industrial sensing and remote equipment monitoring.
- Warehousing, logistics and freight management.
- PC and gaming peripherals.
- Printers, scanners, alarm and video systems.
- Medical applications including patient monitoring and remote diagnostics.

## 2 PART NUMBER DETAIL DESCRIPTION

### 2.1 Ordering Information

Device	Description	Firmware	Ordering Number
ISM43362-M3G-L44	802.11 Module, STM32F205 (1 Mbyte), UART, Internal Etched Antenna	UART	ISM43362-M3G-L44-E-C-xx
		SPI	ISM43362-M3G-L44-E-SPI-Cxx
		USB	ISM43362-M3G-L44-E-USB-Cxx
ISM43362-M3G-L44	802.11 Module, STM32F205 (1 Mbyte), External U.FL Connector	UART	ISM43362-M3G-L44-U-C-xx
		SPI	ISM43362-M3G-L44-U-SPI-Cxx
		USB	ISM43362-M3G-L44-U-USB-Cxx
ISM43362-M3G-EVB-E	Evaluation Board, USB cable, with ISM43362-M3G-L44-E, Quick Start Guide	UART	ISM43362-M3G-EVB-E
ISM43362-M3G-EVB-U	Evaluation Board, USB cable, with ISM43362-M3G-L44-U, Quick Start Guide	UART	ISM43362-M3G-EVB-U

*\*c-xx designates firmware revision – modules shipped with firmware*

## 3 GENERAL FEATURES

- Based on the Broadcom BCM43362 MAC/Baseband/Radio device.
- Supports Broadcom WICED SDK.
- CPU ARM Cortex™-M3 32-bit RISC core from ST Microelectronics.
- Host UART, SPI, or USB-HID interface.
- IEEE 802.11n D7.0 -OFDM-72.2 Mbps -single stream w/20 MHz, Short GI
- IEEE 802.11g (OFDM 54 Mbps)
- IEEE 802.11b (DSSS 11Mbps)
- IEEE 802.11i (Security)
  - WPA (Wi-Fi Protected Access) –PSK/TKIP
  - WPA2 (Wi-Fi Protected Access 2)- AES/CCMP/802.1x Authentication
- Inputs +3.3 V tolerant
- 5 GPIO, 5 ADC (Note: SPI interface utilizes ADC pins.)
- The devices operate from a 3.0 to 3.6 V power supply.
- -40 to +85 °C temperature range.
- Power-saving mode allows the design of low-power applications.
- Lead Free Design which is compliant with ROHS requirements.
- EMI/EMC Metal Shield for best RF performance in noisy environments and to accommodate for lower RF emissions/signature for easier FCC compliance.
- FCC/CE Compliance Certification.

### 3.1 Limitations

Inventek Systems products are not authorized for use in safety-critical applications (such as life support) where a failure of the Inventek Systems product would reasonably be expected to cause severe personal injury or death.

### 3.2 Regulatory Compliance



Regulator	Status
FCC	07P-362
CE	10147A-362
RoHS	Compliant

### 3.3 FCC and IC User's Manual Statements:

#### OEM INSTRUCTIONS:

This module is limited to OEM installation only.

OEM integrators must ensure that the end-user has no manual instructions to remove or install the module.. OEM's must comply with FCC marking regulation part 15 declaration of conformity (Section 2.925(e)).

This module is to be installed only in mobile or fixed applications (Please refer to FCC CFR 47 Part 2.1091(b) for a definition of mobile and fixed devices).

Separate approval is required for all other operating configurations, including portable configurations with respect to FCC CFR 47 Part 2.1093, and different antenna configurations.

The antennas used with this module must be installed to provide a separation distance of at least 20cm from all persons, and must not be co-located or transmit simultaneously with any other antenna or transmitter, except in accordance with FCC multi transmitter product procedures.

The ISM43362 Module has been designed to operate with the following antennas and gains. Use with other antenna types or with these antenna types at higher gains is strictly prohibited.

<b>Manufacturer</b>	<b>Type of Antenna</b>	<b>Model</b>	<b>Gain dB</b>	<b>Type of Connector</b>
Inventek	U.FL port Antenna	W24P-U	2.15	Unique Connector
Inventek	Trace Antenna	NA	0	Permanent integral

**FCC Notice-**

*This device complies with Part 15 of the FCC rules. Operation is subject to the following two conditions: (1) this device may not cause harmful interference, and (2) this device must accept any interference received, including interference that may cause undesired operation.*

Note: This equipment has been tested and found to comply with the limits for a Class B digital device, pursuant to part 15 of the FCC Rules. These limits are designed to provide reasonable protection against harmful interference in a residential installation. This equipment generates uses and can radiate radio frequency energy and, if not installed and used in accordance with the instructions, may cause harmful interference to radio communications.

However, there is no guarantee that interference will not occur in a particular installation. If this equipment does cause harmful interference to radio or television reception, which can be determined by turning the equipment off and on, the user is encouraged to try to correct the interference by one or more of the following measures:

- Reorient or relocate the receiving antenna.
- Increase the separation between the equipment and receiver.
- Connect the equipment into an outlet on a circuit different from that to which the receiver is connected.
- Consult the dealer or an experienced radio/TV technician for help.

Warning: changes or modifications not expressly approved by the party responsible for compliance could void the user's authority to operate this equipment.

A clearly visible label is required on the outside of the user's (OEM) enclosure stat the following text:

Contains FCC ID: O7P-362

Contains IC: 10147A-362

This transmitter module has been certified for FCC Part 15 operation; when installed in a host device, the host manufacturer is responsible for making sure that the host device with the transmitter installed continues to be compliant with Part 15B unintentional radiator requirements



---

**Industry Canada User's Manual Statements:****IC RSS-210/RSS-Gen Notices-**

Operation is subject to the following two conditions: (1) this device may not cause interference, and (2) this device must accept any interference, including interference that may cause undesired operation of this device.

L'opération est soumise aux deux conditions suivantes: (1) cet appareil ne peut pas provoquer d'interférences et (2) cet appareil doit accepter toute interférence, y compris les interférences qui peuvent causer un mauvais fonctionnement de l'appareil.

Under Industry Canada regulations, this radio transmitter may only operate using an antenna of a type and maximum (or lesser) gain approved for the transmitter by Industry Canada. To reduce potential radio interference to other users, the antenna type and its gain should be so chosen that the equivalent isotropically radiated power (e.i.r.p.) is not more than that necessary for successful communication.

Sous la réglementation d'Industrie Canada, ce transmetteur radio ne peut fonctionner en utilisant une antenne d'un type et un maximum (ou moins) gain approuvées pour l'émetteur par Industrie Canada. Pour réduire le risque d'interférence aux autres utilisatrices, le type d'antenne et son gain doivent être choisis de manière que la puissance isotrope rayonnée équivalente (PIRE) ne dépasse pas ce qui est nécessaire pour une communication réussie.

The radio transmitter has been approved by Industry Canada to operate with the antenna types listed above with the maximum permissible gain and required antenna impedance for each antenna type indicated. Antenna types not included in this list having a gain greater than the maximum gain indicated for that type, are strictly prohibited for use with this device.

Cet émetteur de radio a été approuvé par Industrie Canada pour fonctionner avec les types d'antennes énumérées ci-dessus avec le gain maximal admissible et impédance d'antenne requise pour chaque type d'antenne indiquée. Types d'antennes ne figurant pas dans cette liste, ayant un gain supérieur au gain maximum indiquée pour ce type, sont strictement interdites pour l'utilisation avec cet appareil.

## 4 COMPLEMENTARY DOCUMENTATION

### 4.1 Inventek Systems

- Evaluation Board
  - ISM43362-M3G-EVB Evaluation Board Specification
  - EVB User's Guide
  - Quick Start Guide
  - eS-WiFi Demo software (includes EVB Drivers and Firmware)
- AT Command Set
  - AT Command Set User's Manual
  - AT Command Set Quick Reference Guide
- Firmware
- OrCAD Schematic Symbol
- PADS Land Pattern
- FCC Test Report

## 5 SPECIFICATIONS

### 5.1 Module Architecture

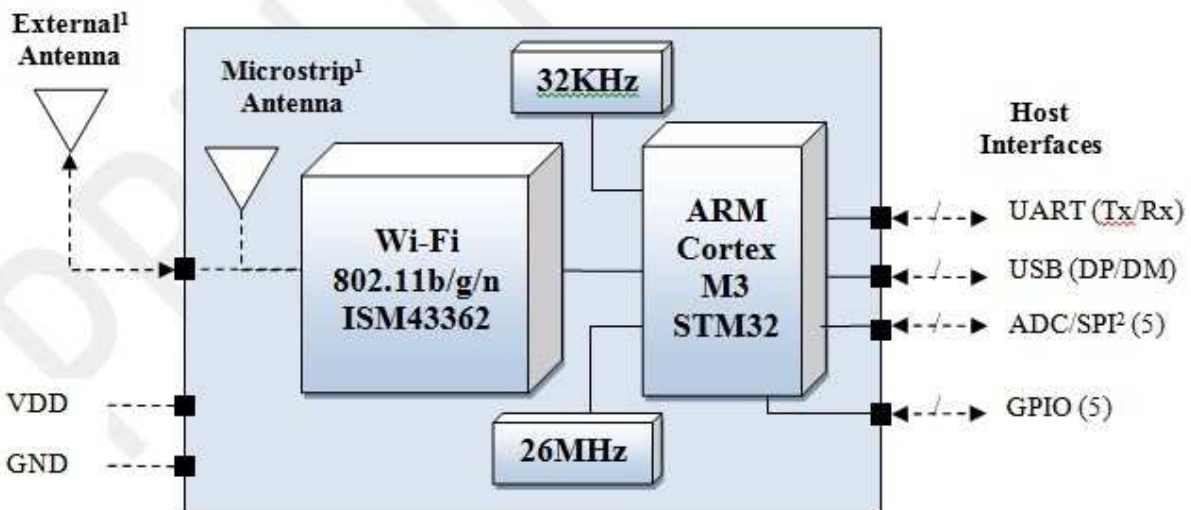

Figure 1 Inventek's ISM43362-M3 General Block Diagram

- Note:
1. Antenna Options: Integrated microstrip antenna or U.FL connector for an external antenna.
  2. ADC1-ADC5 can also be used as SPI port

## 5.2 External Antenna Connections

ISM43362-M3G-L44-U module is designed for use with an external antenna via a connection using the U.FL connector.

Item	Description
Connector	U.FL series
Manufacturer	I-PEX Co., Ltd.
Part No.	20279-001E-01
Height	1.25 mm
Width	2 mm
DC	3.0 – 5.0 V

Table 1 On-Board Antenna Connector

## 5.3 Mechanical Specifications

The Physical dimensions of this eS-WiFi Module are as follow:

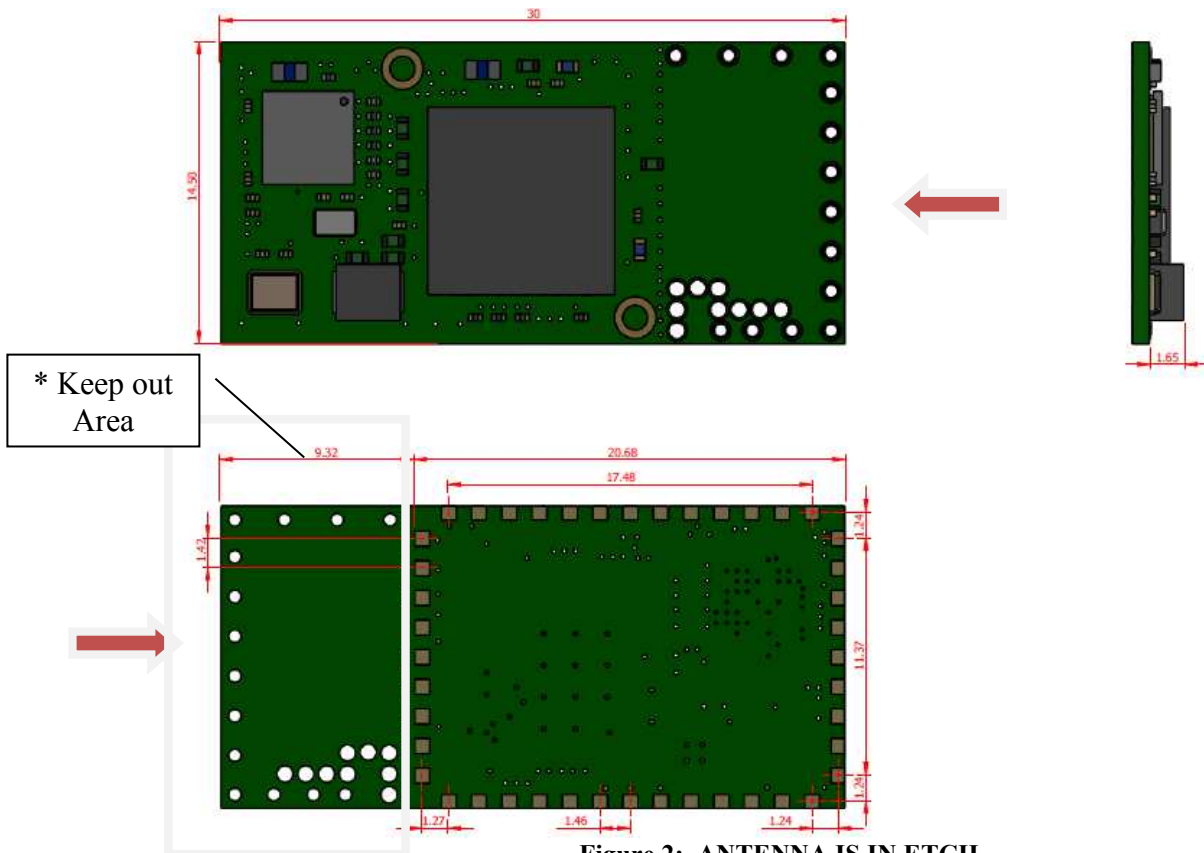

Figure 2: ANTENNA IS IN ETCH

\* External Antenna does not require “keep out” area  
 ”Keep out” area should ideally have the antenna hanging off the side of the PCB for best performance. If you do not hang the antenna off the PCB, ensure no ground planes or traces are placed under the antenna (keep out area). Surrounding metal will affect the antenna performance. The ISM43362-M3G-L44- U and -E have the same footprint.

Items	Description
	<b>ISM43362-M3G-L44-E /U</b>
Length	30 mm (-/+0.5 mm)
Width	14.5 mm (-/+0.5 mm)
Height	2.5 ± 0.2 mm
Package	44 pin LGA

## 5.4 Environmental Specifications

Item	Description
Operating temperature range	-40 deg. C to +85 deg. C
Storage temperature range	-40 deg. C to +85 deg. C
Humidity	95% max non-condensing

Note 1: The ISM43362-M3G supports a functional operating range of -40°C to +85°C. However the optimal RF performance specified in this data sheet is only guaranteed for temperatures from -10°C to +65°C

## 6 HARDWARE ELECTRICAL SPECIFICATIONS

### 6.1.1 Absolute Maximum Ratings

Symbol	Description	Min	Max	Unit
VDD	Input supply Voltage	-0.4	3.7	V
VBAT	Battery Backup	-0.4	3.6	V

### 6.1.2 Recommended Operating Ratings

Symbol	Min.	Typ.	Max.	Unit.
VDD	3.0	3.3	3.6	V
VBAT	3.0	3.3	3.6	V

## 7 Power Consumption

### 7.1.1 Estimated Power Consumption

Mode/Description	802.x	Voltage	Typ.	Max.	Unit
Running Full Power <sup>(1)</sup>	/n	3.3V	110		mA
Running in Power Save Mode	/n	3.3V	55	110 <sup>(1)</sup>	mA
Wi-Fi Radio Off	b/g/n		30		mA
Stop Mode <sup>(2)</sup>			10		mA

Note:

<sup>(1)</sup>During transmit the maximum current can reach 340 mA burst of not more than 5ms.

<sup>(2)</sup>Available in Firmware release 1.3 or later only.

The eS-WiFi modules support multiple power saving modes. Please see the power savings application note for more detailed information

### 7.1.2 Stop Mode

Stop Mode is initiated by software and exited by the an input on the Wakeup pin. (Wakeup pin is 3.3 volt tolerant). The wakeup pin is an external interrupt pin that on the rising edge will cause the module to exit stop mode. It is an edge triggered input. It is critical to have no glitch on this line.

## 8 Pin out

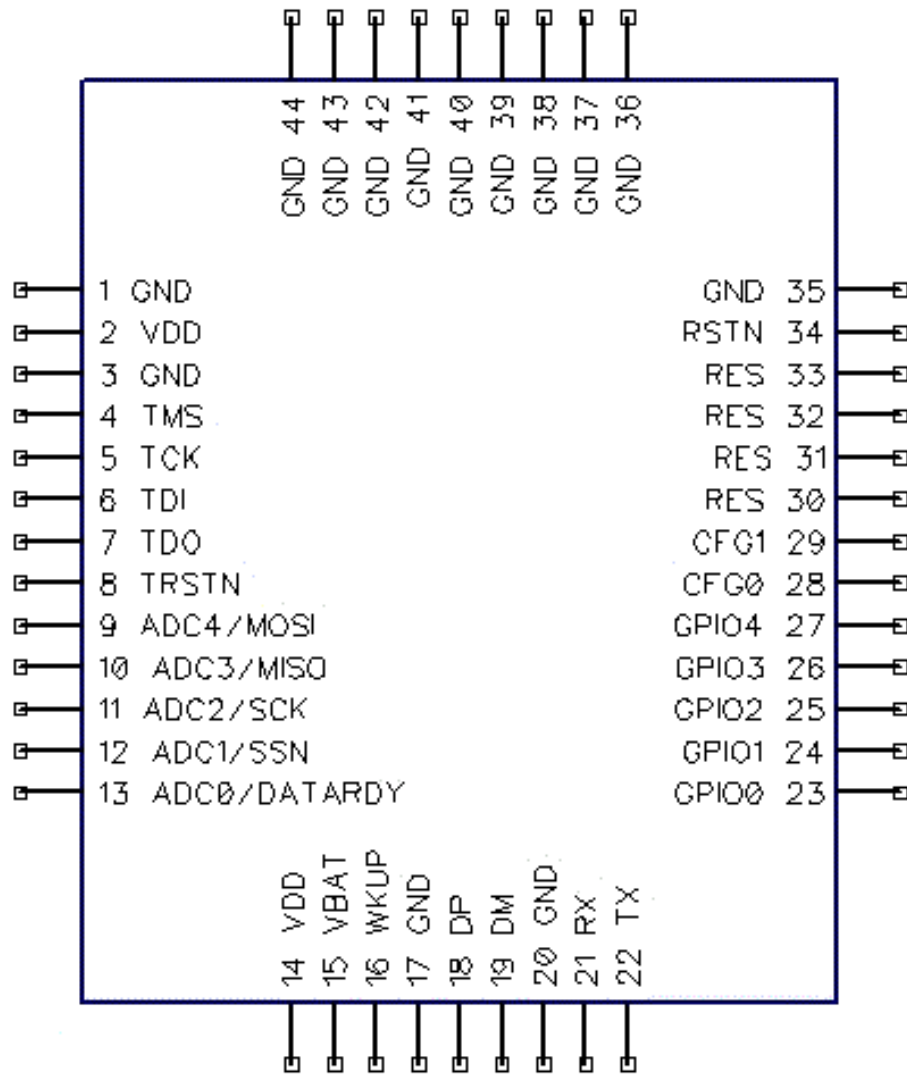

### 8.1.1 Detailed Pin Description

Pin No.	Type	Pin Definition	Descriptions
1	G	GND	Ground
2	I	VDD	3.3V
3	G	GND	Ground
4	I/O	TMS	JTAG
5	I/O	TCK	JTAG
6	I/O	TDI	JTAG
7	I/O	TD0	JTAG
8	I/O	TDRSTN	JTAG
9	I/O	ADC 4 / SPI_MOSI	ADC Input Pins or SPI Host Interface (Refer to SPI Section 10.2)
10	I/O	ADC 3 / SPI_MISO	
11	I/O	ADC 2 / SPI_SCK	
12	I/O	ADC 1 / SPI_SSN	
13	I/O	ADC 0 (I)/ DATARDY (O)	
14	I	VDD	3.3V
15	I	VBAT	3.3V
16	I	Wakeup	(Refer to Section 7.1.2)
17	G	GND	Ground
18	I	DP	USB Data Plus (Refer to Table 8.1.2)
19	I/O	DM	USB Data Minus (Refer to Table 8.1.2 )
20	G	GND	Ground
21	I/O	RX	UART Receive (Refer to section 10.1 )
22	I/O	TX	UART Transmit (Refer to section 10.1 )
23	I/O	GPIO 0	General Purpose Interface Pins
24	I/O	GPIO 1	
25	I/O	GPIO 2	
26	I/O	GPIO 3	
27	I/O	GPIO 4	
28	I	CFG0	Configuration Pin 0 (Refer to Table 8.1.2 )
29	I	CFG1	Configuration Pin 1 (Refer to Table 8.1.2 )
30	O	RES	Reserved
31	I	RES	Reserved
32	I	RES	Reserved
33	I	BOOT 0	Reserved
34	I	RSTN	Reset (See STM32F205 NRST specification )
35	G	GND	Ground
36	G	GND	Ground

Pin No.	Type	Pin Definition	Descriptions
37	G	GND	Ground
38	G	GND	Ground
39	G	GND	Ground
40	G	GND	Ground
41	G	GND	Ground
42	G	GND	Ground
43	G	GND	Ground
44	G	GND	Ground

### 8.1.2 Configuration Pins:

CFG0	CFG1	Internally Pulled High
1	1	UART ( NC)
1	0*	SPI
0*	1	USB VCP
0*	0*	USB HID

\*Requires a 10K ohm pull down

Note: These pins are not used in the currently available production firmware. Modules are preprogrammed with separate and specific firmware that supports either UART, SPI or USB HID. In future versions of the firmware these pins will be used to select the host interface type.

## 9 Firmware Upgrades during Development

We recommend using a JTAG 10 pin header or directly connecting to the JTAG pins on the module for updating. Use the ST-Link to flash the ST micro.

Below are links to the ST-Link and JTAG header at Digikey:

STLink:

<http://www.digikey.com/product-detail/en/ST-LINK%2FV2/497-10484-ND/2214535>

[The 10 to 20 pin JTAG adapter is Digi-Key PN 726-1193-ND:](http://www.digikey.com/product-detail/en/MDL-ADA2/726-1193-ND/1986451)

<http://www.digikey.com/product-detail/en/MDL-ADA2/726-1193-ND/1986451>

## 10 Serial Host Interfaces Available

UART, SPI and USB-HID host interfaces are supported and unique firmware is required for each interface.

### 10.1 UART

A universal asynchronous receiver / transmitter (UART) with 3.3v logic levels is available.



### 10.1.1 Data Mode

When the eS-WiFi module is interfaced serially, the serial interface needs to be configured for 8 bit data, no parity, and one stop bit -- (8-n-1).

### 10.1.2 Flow Control

The eS-WiFi module doesn't require or support Flow Control, so Flow Control should be 'None'

### 10.1.3 Supported Baud Rates

The eS-WiFi module uses USART1 (PA9 and PA10 of the STM32F205) and the following serial baud rates are supported: 1200, 2400, 4800, 9600, 19200, 38400, 57600, 115200, 230400, 460800, 921600, 1152000, 1382400, 1612800, 1834200, 2073600. USART1 can be run at higher rates but have not been tested with the AT command set.

### 10.1.4 Default Serial Configuration

The eS-WiFi module is shipped with the default serial configuration of 115200 baud, 8 data bits, no party, and 1 stop bits.

## 10.2 SPI (Serial Peripheral Interface Bus)

The eS-WiFi module supports SPI (Contact Inventek for specific firmware.)

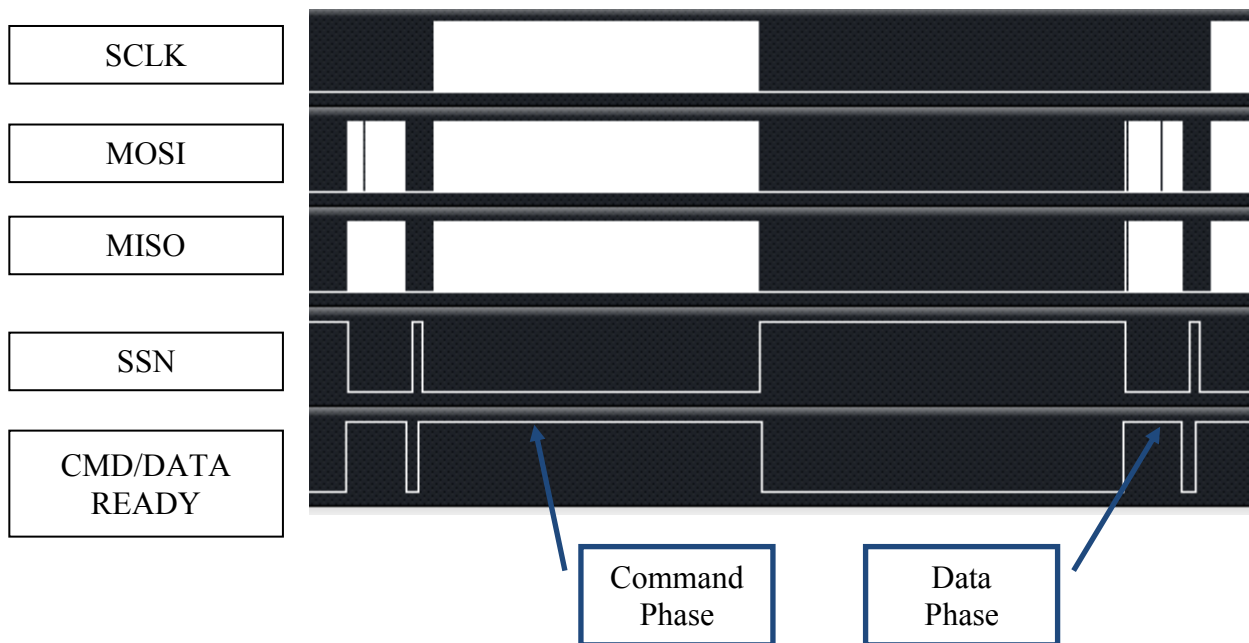

**SPI Slave Interface:**

Clock rate: 20MHz max.  
 Width: 16-bit  
 Mode: 0  
 Endian: Little

Note: All commands to the eS-WiFi module must be post-padded with 0x0A (Line Feed) to an even number of bytes.  
 All data from eS-WiFi module will be post-padded with 0x15(NAK) to an even number of bytes.

### 10.2.1 SPI Communication Overview:

With the exception of initial cursor, all communication with the module happens synchronously. In other words, the SPI Master must always poll for every asynchronous event.

A typical command flow is provided flow. This is an example using the Direct Connect Soft AP with a TCP communication server.

SPI Master	SPI Slave (eS-WiFi)	Description
	“\r\n> “	Prompt
“AS=0,ABC\r\x0A”	"\r\n\r\nOK\r\n> "	Set Access Point SSID
“AD\r\ x0A”	"\r\n\r\nOK\r\n> "	Start AP - Direct Mode
"P1=0\r\ x0A”	"\r\n\r\nOK\r\n> "	Set TCP Protocol
"P4=2000\r"	"\r\n\r\nOK\r\n> "	Set TCP Port
"P5=1\r\ x0A”	"\r\n\r\nOK\r\n> "	Start TCP COMM Server
"MR\r\ x0A”	"\r\n[SOMA]...[EOMA]\r\nOK\r\n> "	Read Messages

Note: [SOMA] - Start of Message Asynchronous, [EOMA] - End Of Message Asynchronous

The SPI communication is always 16-bit and can be sustained up to 20MHz. The eS-WiFi module after power up or reset will raise CMD/DATA READY pin to signal that the first Data Phase has started. In this mode, the SPI Host must fetch the cursor. As provided by the example above, this is the only time host needs fetch data from slave without issuing a command.

The Host will initiate a SPI cycle (lower SSN) and clock out 0x0A (Line Feed) until the CMD/DATA READY pin lowers signaling the end of the Data Phase. The data received will be 0x0d (CR) 0x0A (LF) 0x3E (>) 0x20 (SP).

The next rising edge of the CMD/DATA READY pin signals the Command Phase.

### 10.2.2 SPI Command Phase:

The Command Phase indicates the eS-WiFi module is ready to accept an AT Command. The command must include all delimiters and data for the command.

Ex. S3=0010\r0123456789

The command must also be sent as one continuous SPI cycle, that is SSN must stay low for the complete command, delimiters, and data.

The Host will initiate a SPI cycle (lower SSN) and clock out the command, delimiters and associated data and raise the NSS signal to indicated that the all data has be sent. As result of the NNS raising the eS-WiFi module will lower the CMD/DATA READY pin to signal the end Command Phase.

The data that will be clocked back to the Host will be 0x15 (NAK).

### 10.2.3 SPI Endian Example:

The data is in little endian (0x15 0x15 0x0A 0x0D 0x20 0x3E) and needs to be converted back to big endian with the leading 0x15's removed. Please remember that this is a 16-bit interface so the endian conversion is done one 16-bit at a time.

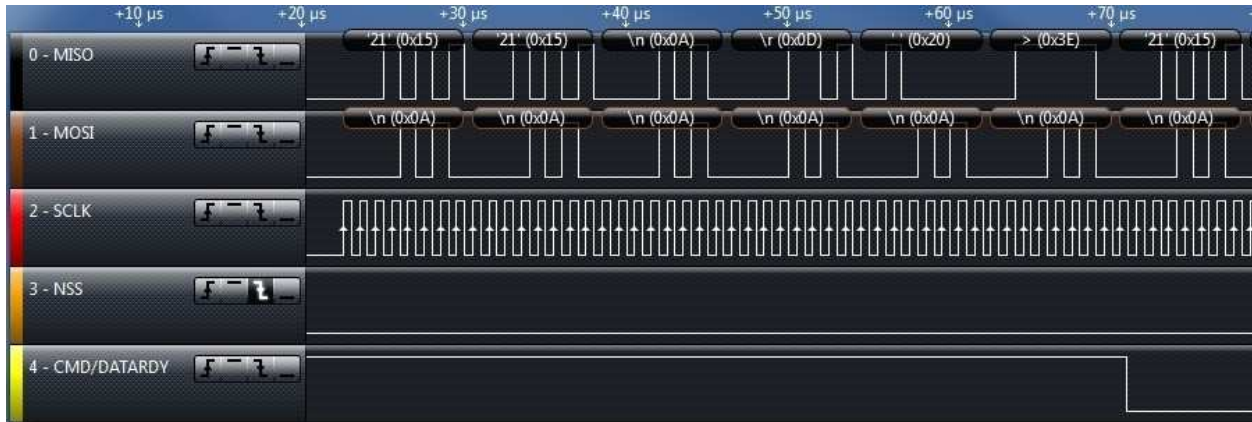

The endian requirement extends to the command being sent to the module. So a “I?\r\x0A” command would be sent as 0x3F 0x49 0x0A 0x0D.



#### 10.2.4 SPI Data Phase:

The Data Phase indicates the eS-WiFi module has data ready for the Host to read. The eS-WiFi module will raise CMD/DATA READY and the Host will initiate a SPI cycle (lower SSN) and clock out 0x0A (Line Feed) until the CMD/DATA READY pin lowers signaling the end of the Data Phase.

#### 10.2.5 SPI Asynchronous Messages:

There are certain situations in which the eS-WiFi will issue asynchronous messages:

- Soft AP (AO/AD Commands), when a device connects to the Soft AP a DHCP assigned message will be issued.  
Ex. [DHCP ] Assigned 00:00:00:00:00:00 has 192.168.10.100
- TCP/UDP Communication Servers (P5=1), when a client connects to the server a connected message will be issued.  
Ex. [TCP SVR] Waiting on connection...  
[TCP SVR] Accepted 192.168.10.100:2000  
[UDP SVR] Accepted 192.168.10.100:2000

With the SPI host interface being synchronous the Host must poll for these messages. This can be done by using the MR (Message Read) command or when a Communication connection the issuing of a R0 command will read all asynchronous message and the result of the R0 command. The asynchronous messages are delineated by the Start Of Message Asynchronous ([SOMA]) and End Of Message Asynchronous ([EOMA]) markers.

## 10.2.6 SPI AC Characteristics:

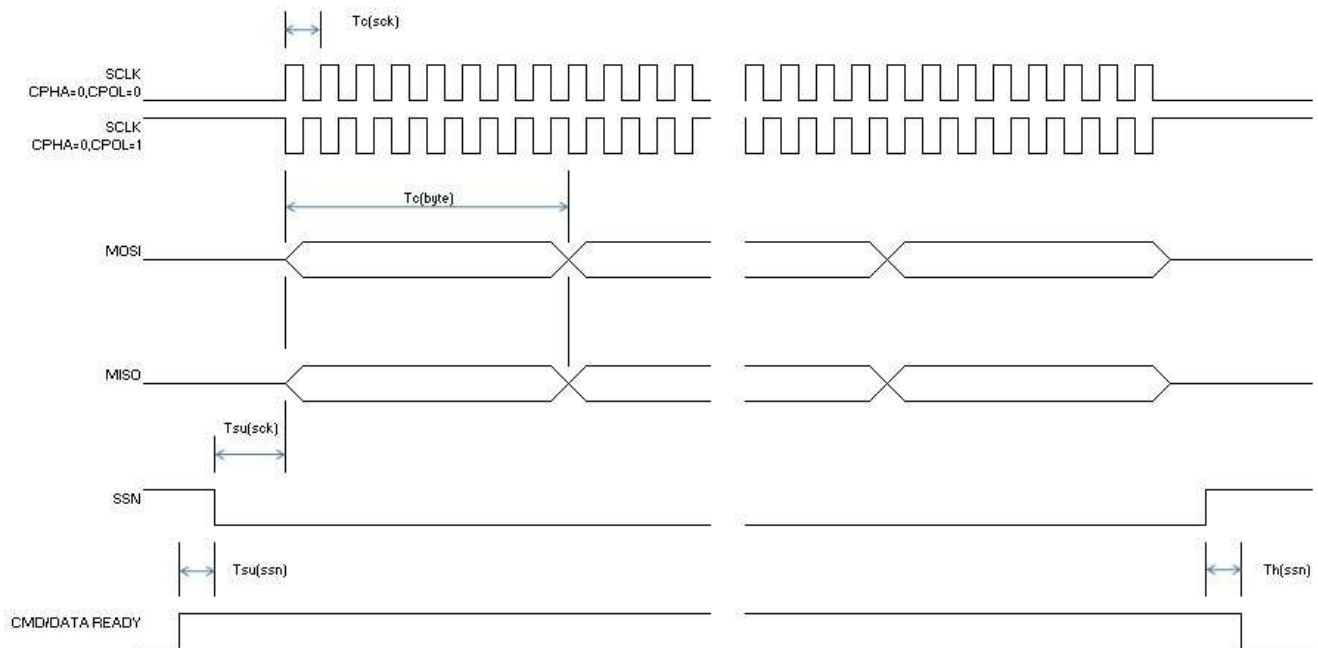

Symbol	Min.	Typ.	Max.
$T_f(sck)$			20 MHz
$T_c(sck)$	50 ns		
$T_{su}(sck)$		15 us	
$T_c(byte)$		$8 * T_c(sck)$	
$T_{su}(ssn)$		4 us	
$T_h(ssn)$		3 us	

## 10.3 USB

The eS-WiFi module supports a USB HID interface. (Contact Inventek for specific firmware.)

## 10.4 GPIO

Each of the GPIO pins can be configured by the AT command set as Button, LED, Digital input or Digital output. The outputs are 3.3V CMOS and reference the AT Command Set User manual to configure.

## 10.5 ADC's

One 12-bit analog-to-digital converter is available. Reference the AT Command Set User's manual for configuration.

## 11 Wi-Fi RF Specification

### 11.1.1 RF Specification

Conditions: VDD=3.3V; VDDIO=3.3V; TEMP: 25°C

Feature	Description
WLAN Standard	IEEE 802.11b/g/n, Wi-Fi compliant
Frequency Range	2.400 GHz ~ 2.497 GHz (2.4 GHz ISM Band)
Number of Channels	Ch1 ~ Ch14
Modulation	802.11 g/n : OFDM /64-QAM,16-QAM, QPSK, BPSK 802.11b : CCK, DQPSK, DBPSK
Output Power	802.11b /11Mbps : 20 dBm ± 1.5 dB
	802.11g /54Mbps: 20 dBm ± 1.5 dB
	802.11n /72Mbps: 20 dBm ± 1.5 dB
Receive Sensitivity (11n,20MHz) @10% PER	- MCS=0 PER @ -86 dBm, typical
	- MCS=1 PER @ -85 dBm, typical
	- MCS=2 PER @ -85 dBm, typical
	- MCS=3 PER @ -84 dBm, typical
	- MCS=4 PER @ -80 dBm, typical
	- MCS=5 PER @ -78 dBm, typical
	- MCS=6 PER @ -72 dBm, typical
Receive Sensitivity (11g) @10% PER	- 6Mbps PER @ -89 dBm, typical
	- 9Mbps PER @ -88 dBm, typical
	- 12Mbps PER @ -88 dBm, typical
	- 18Mbps PER @ -87 dBm, typical
	- 24Mbps PER @ -83 dBm, typical
	- 36Mbps PER @ -80 dBm, typical
	- 48Mbps PER @ -75 dBm, typical
	- 54Mbps PER @ -72 dBm, typical
Receive Sensitivity (11b) @10% PER	- 1Mbps PER @ -93 dBm, typical
	- 2Mbps PER @ -91 dBm, typical
	- 5.5Mbps PER @ -89 dBm, typical
	- 11Mbps PER @ -87 dBm, typical
Data Rates	802.11b : 1, 2, 5.5, 11Mbps
	802.11g : 6, 9, 12, 18, 24, 36, 48, 54Mbps
Data Rate (20MHz ,Long GI,800ns)	802.11n: 6.5, 13, 19.5, 26, 39, 52, 58.5, 65Mbps

Data Rate (20MHz ,short GI,400ns)	802.11n : 7.2, 14.4, 21.7, 28.9, 43.3, 57.8, 65,72.2Mbps
Maximum Input Level	802.11b : -10 dBm
	802.11g : -10 dBm

## 12 Antenna Patterns

### 12.1 External Antenna

The Inventek U.FL PCB antenna has passed FCC and CE testing. The part number is W24P-U. It is a 2.4 GHz PCB antenna with a U.FL connector.

The eS-Wifi family of Wi-Fi products comes with two different antenna offerings:

ISM43362-M3G-L44-E	PCB Etched Antenna
ISM43362-M3G-L44-U	U.FL connector for external antenna

The Inventek W24P-U PCB antenna is FCC and CE certified and can be found on the Inventek Website.

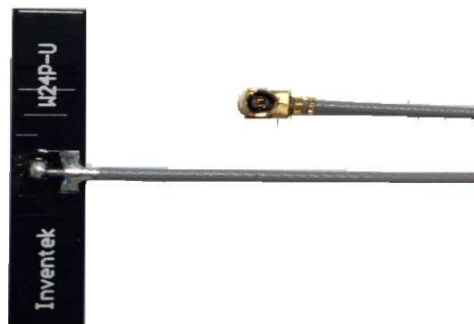



## 12.2 PCB Etch Antenna Gain on the Evaluation Board

The eS-WiFi PCB etched antenna performance is shown below. This etched antenna is FCC and CE certified and the radiation patterns shown below are based on simulation using evaluation boards that have a ground plane with dimensions of 71mm x 48mm.

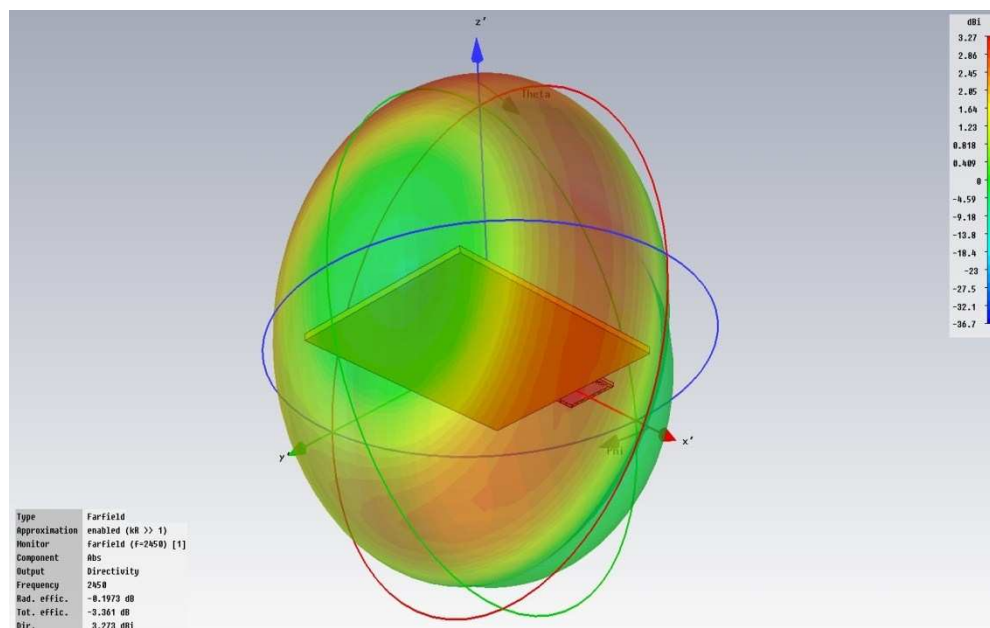
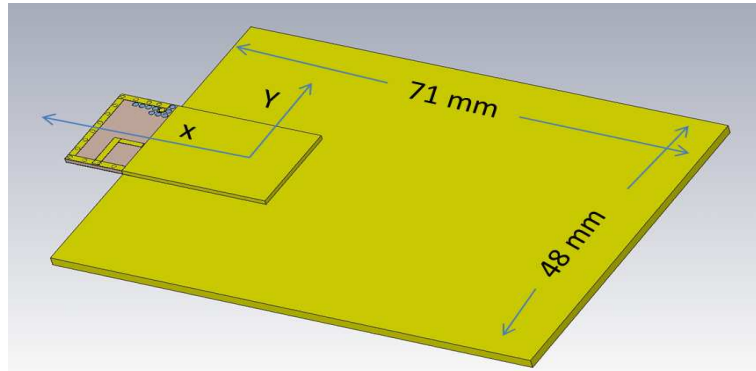



## 12.3 Farfield Directivity

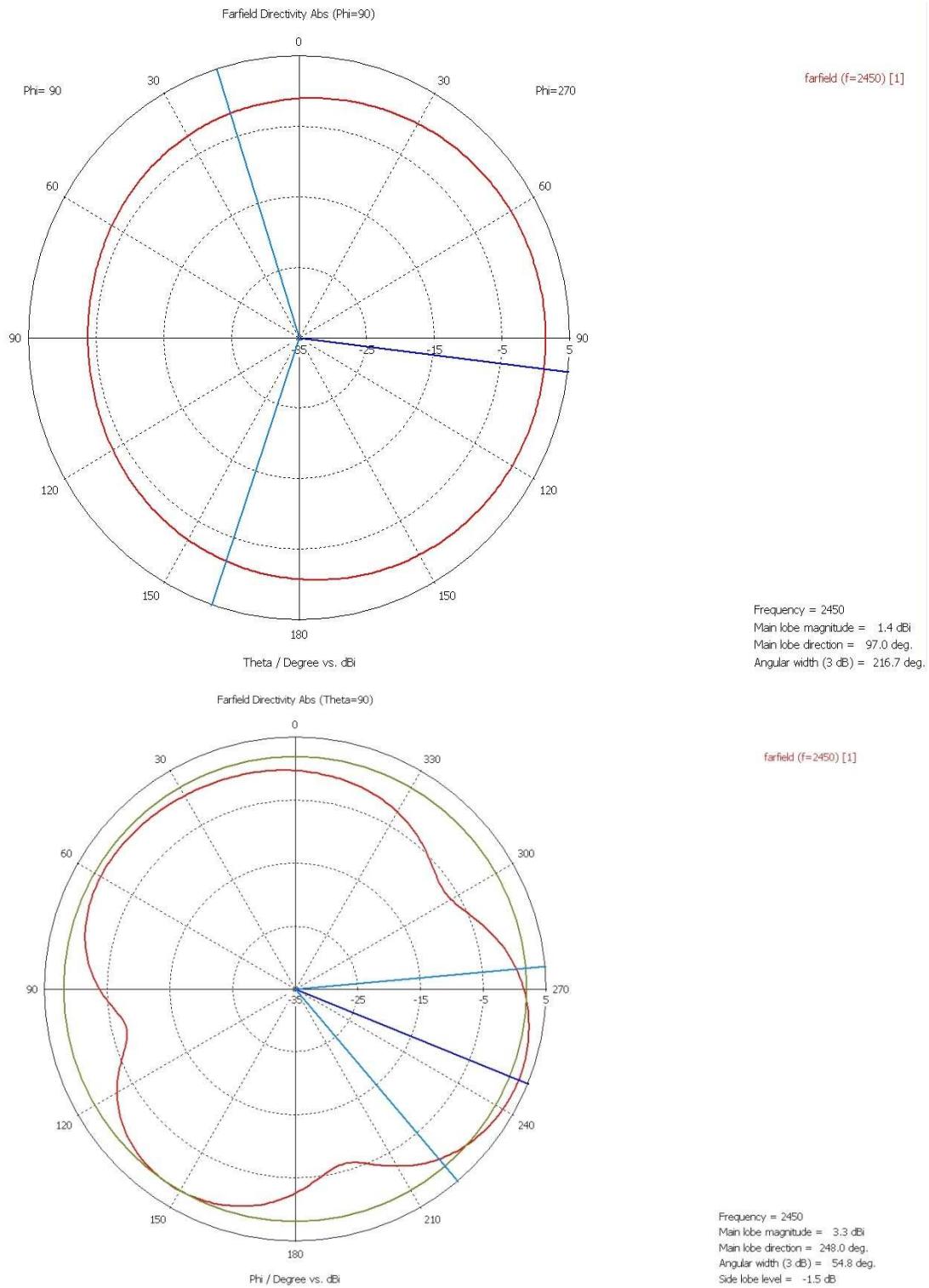

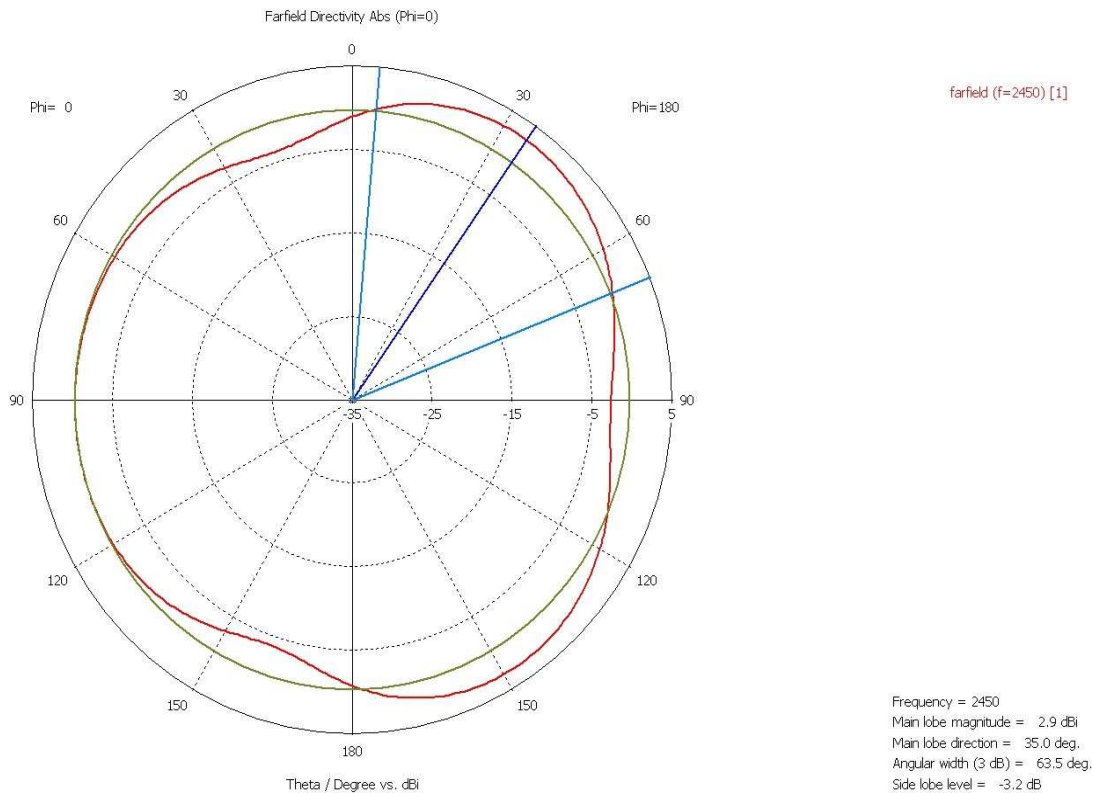

### 13 On Board Processor

The eS-WiFi module is available with ST Microcontroller, F205 family of processors.

ISM43362-M3G-L44 -E	STM32F205 (1 Meg), Flash Microcontroller
ISM43362-M3G-L44-U	STM32F205 (1Meg), Flash Microcontroller

See the STM32F205 specification from ST Microelectronics for UART, SPI (Slave Mode) and USB Device.

<http://www.st.com/st-web-ui/static/active/en/resource/technical/document/datasheet/CD00237391.pdf>

## 14 ISM43362-M3G-L44 FOOTPRINT

### 14.1 Module's dimensions top view (mm)

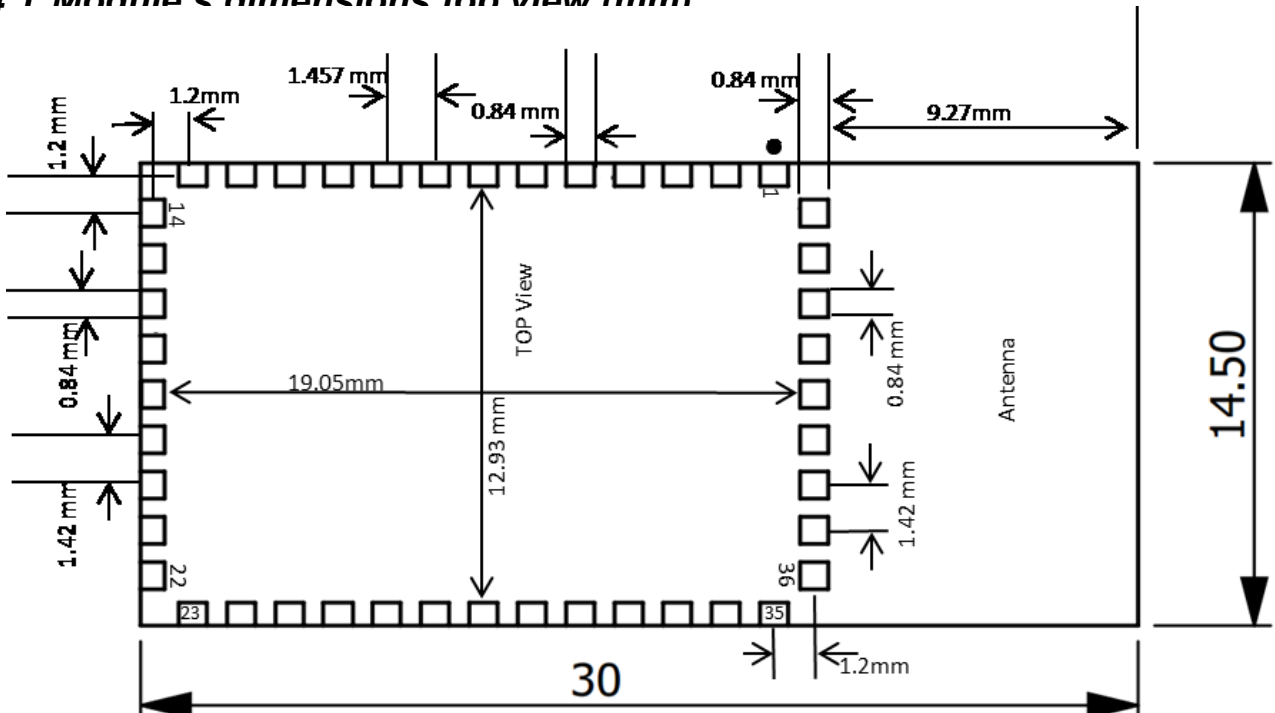

Figure 3 Module Dimensions- Top View

### 14.2 PCB recommended footprint top view (mm)

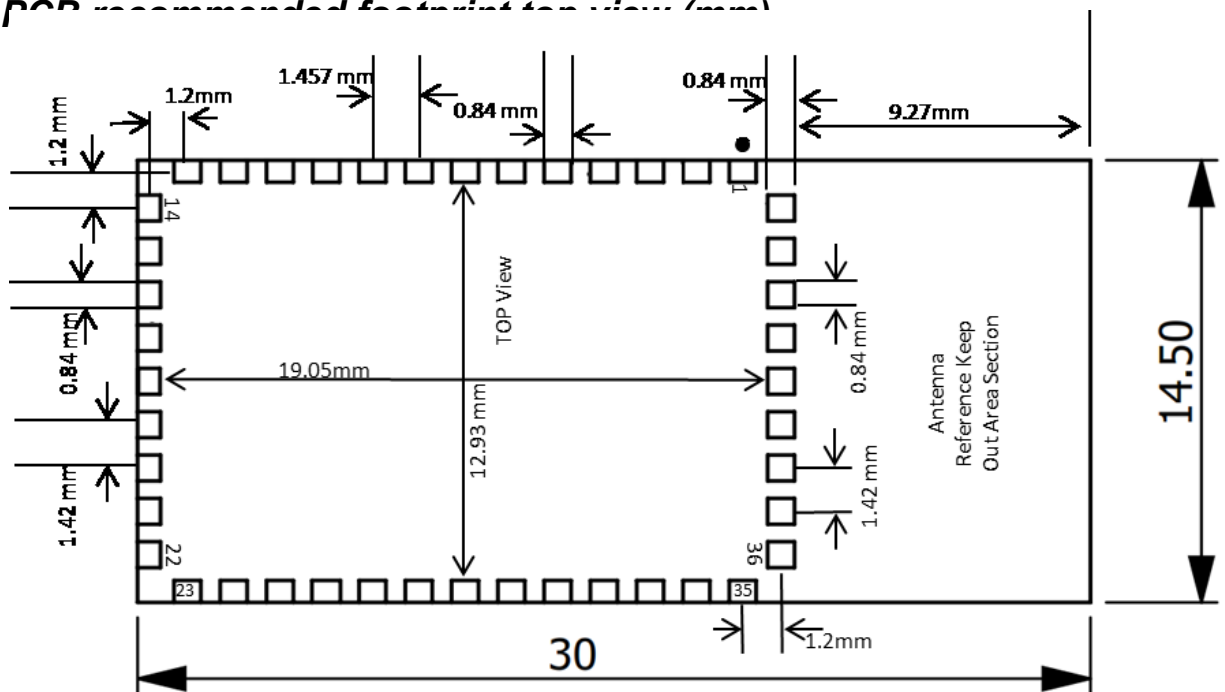
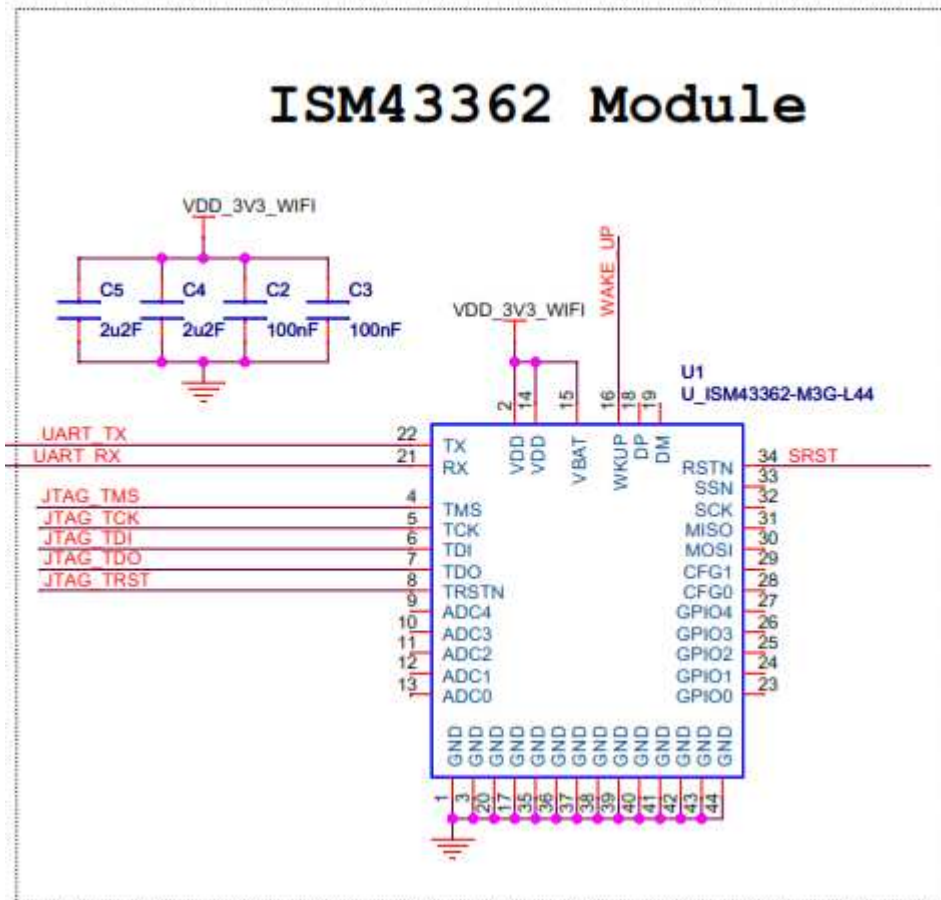

Figure 4 PCB Recommended Foot print - Top View

## 15 Typical Application Circuit

This is the minimum number of wires required to be connected to a host microcontroller for operation in UART mode. It is recommended that the JTAG lines are also brought out for future firmware upgrades.



## 15.1 Reference Schematic (EVB)

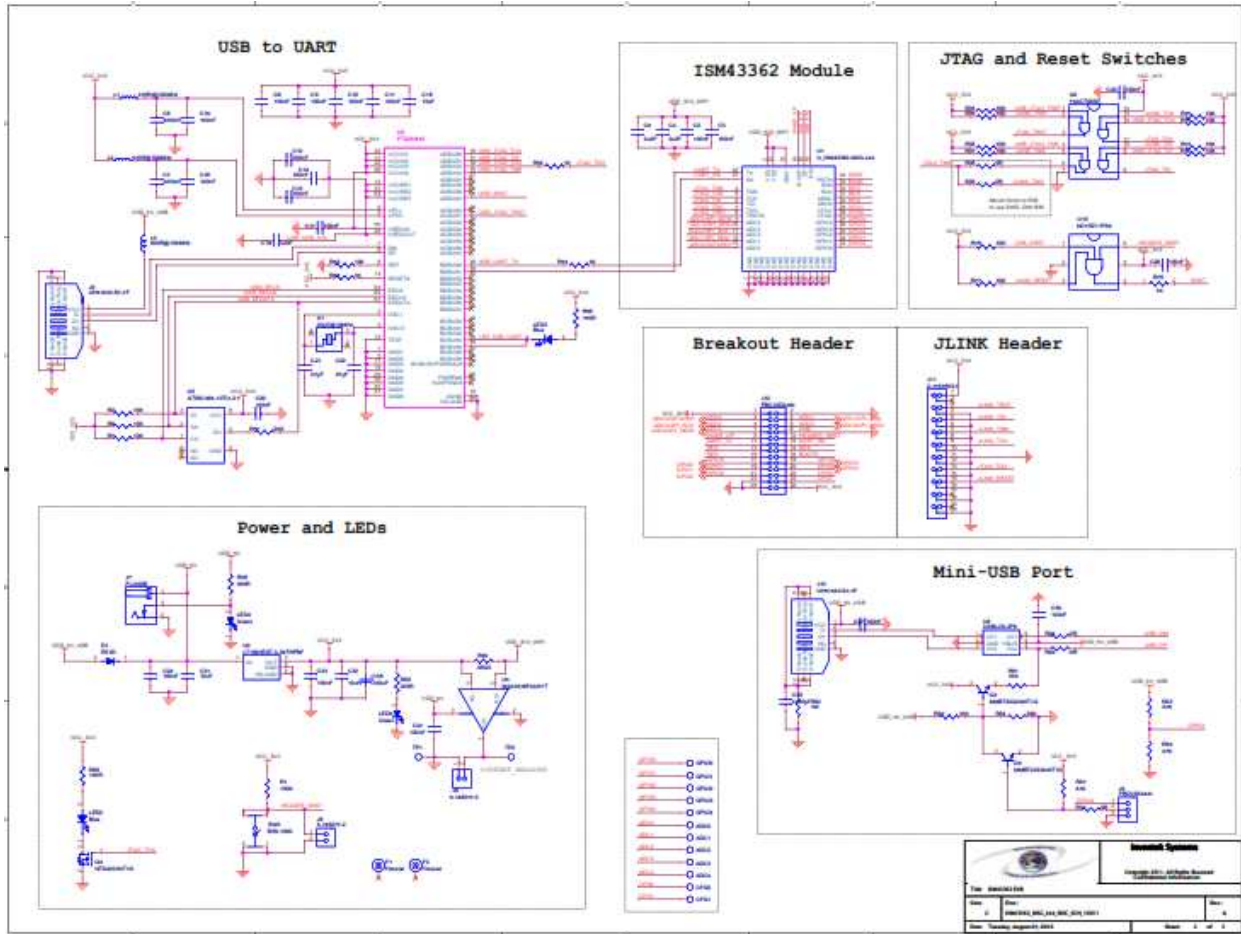

Typical application circuits please refer to schematic below. For a \*.pdf version please visit the Wi-Fi ISM43362 evaluation board website, [www.Inventeksys.com](http://www.Inventeksys.com).

## 15.2 USB to UART

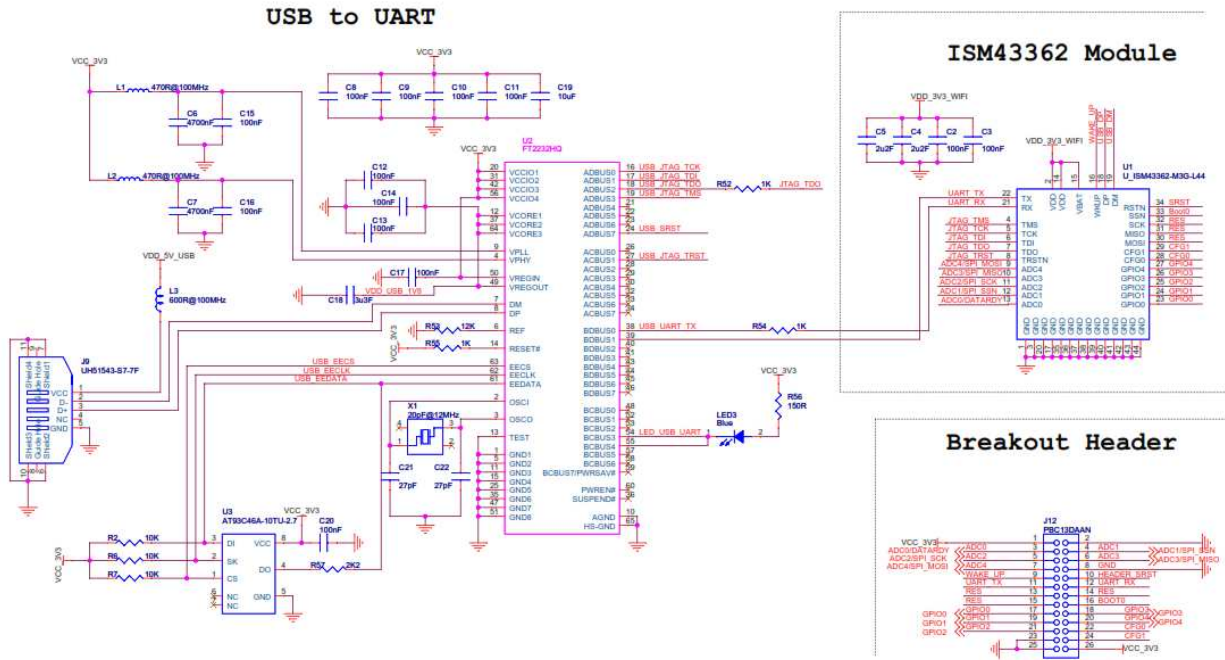



### 15.3 Connecting Microcontroller to eS-WiFi UART

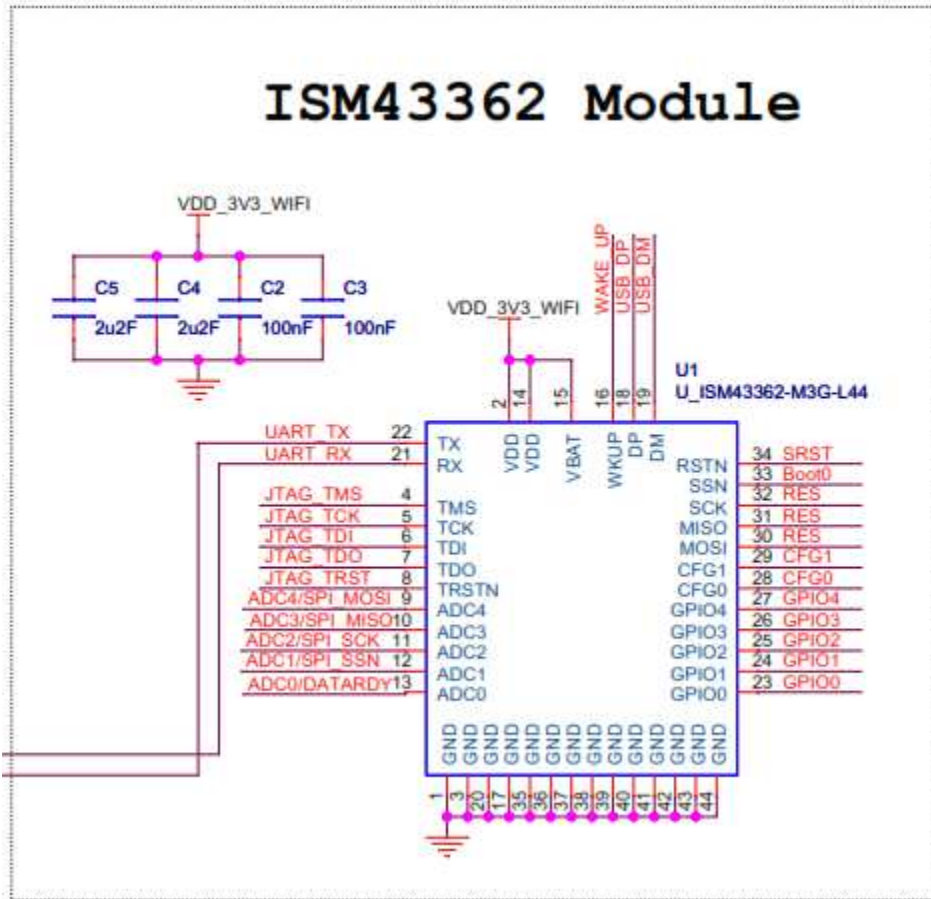

### 15.4 EXTERNAL FLASH FOR OVER THE AIR UPGRADE

(In development, contact Inventek)

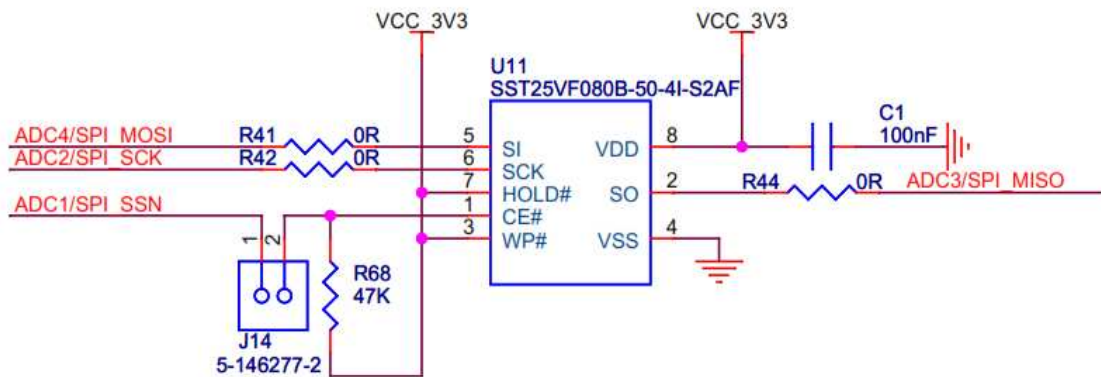

## 15.5 JTAG and Reset Connections

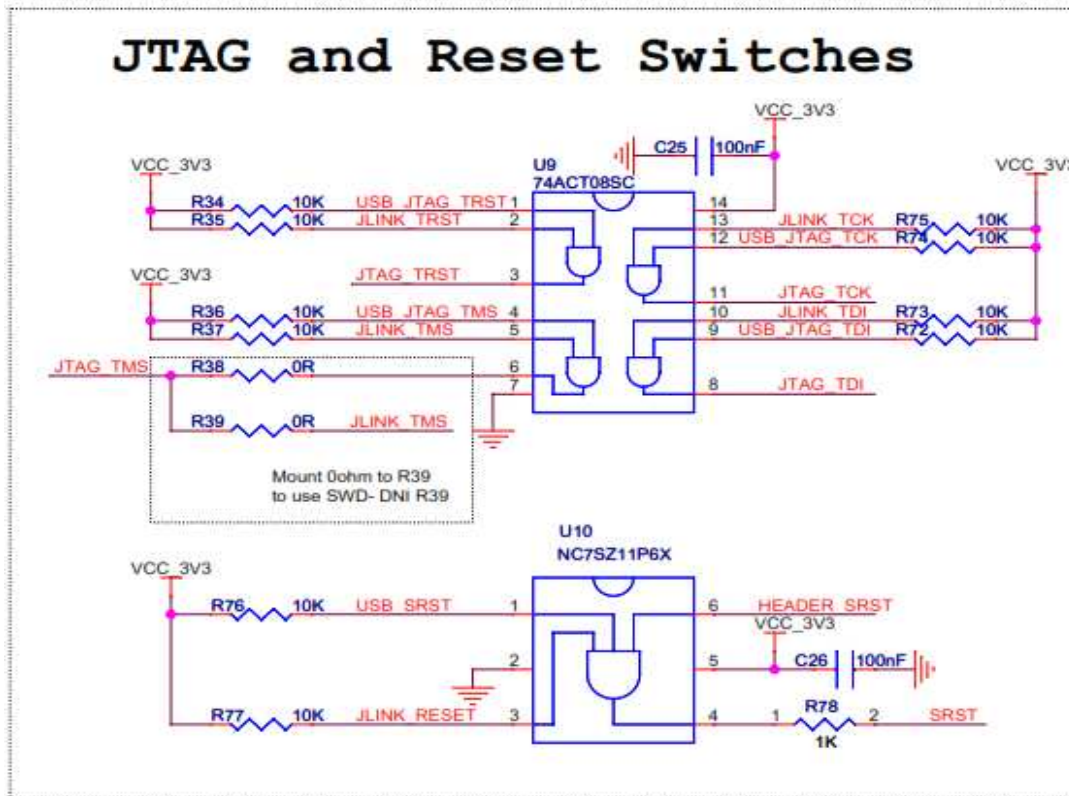

## 15.6 eS-WiFi Programming Options

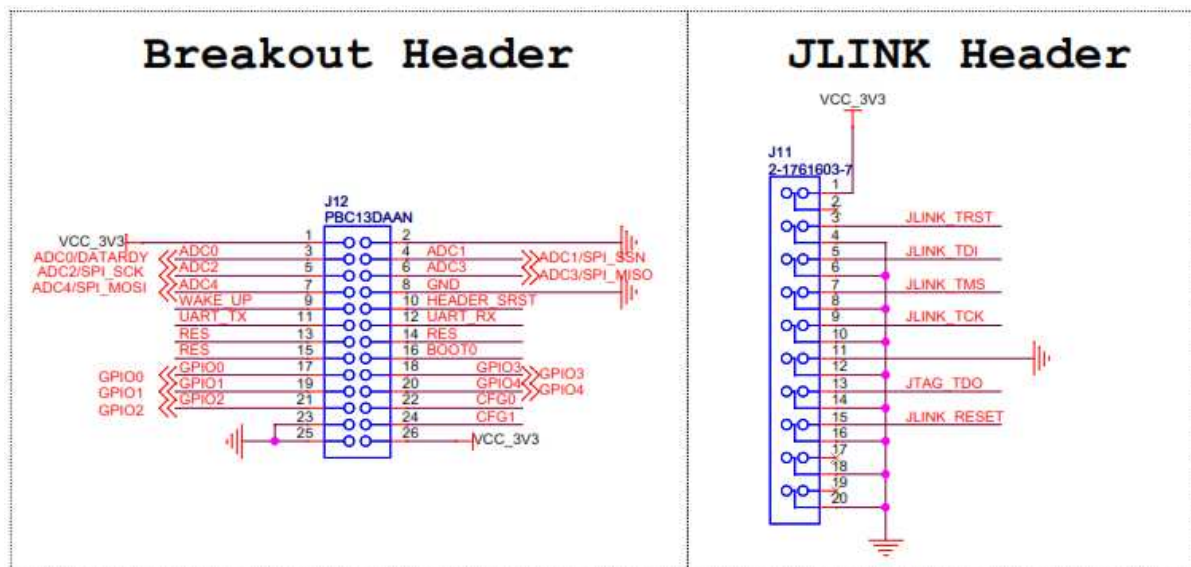



## 15.7 eS-WiFi USB Direct Connection Option

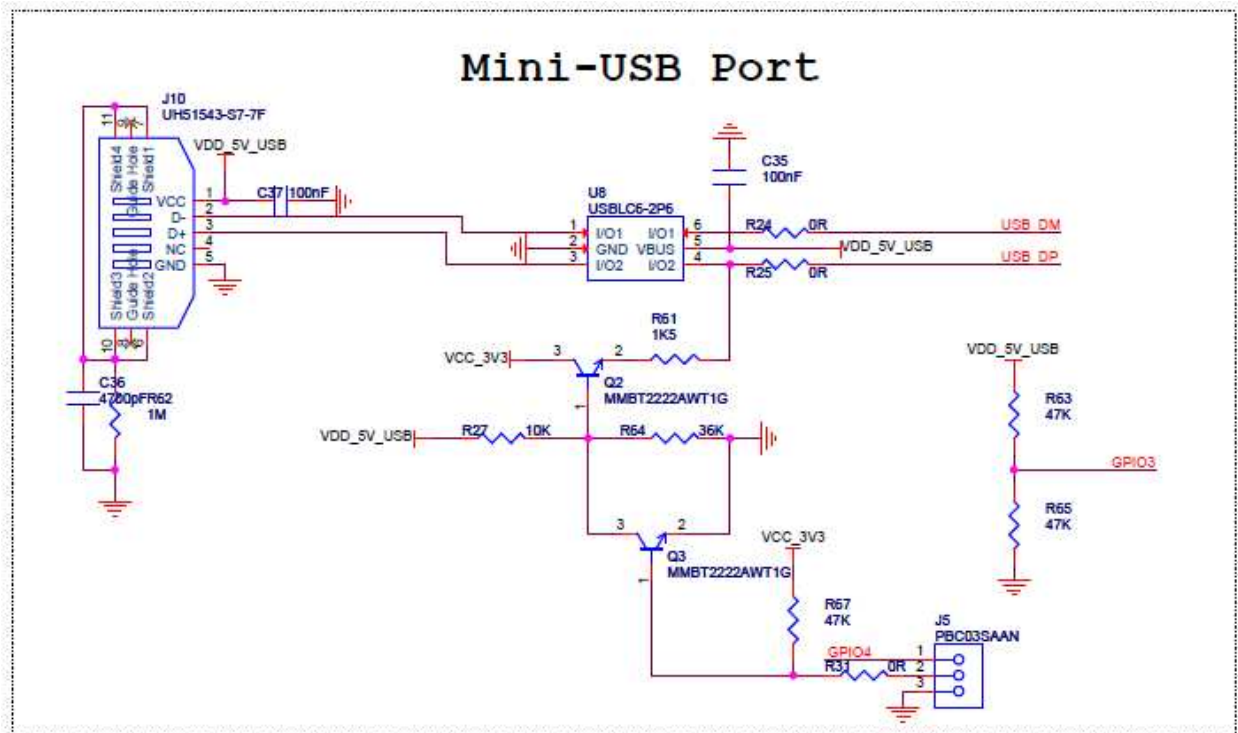

## 16 Product Compliance Considerations

**RoHS:** Restriction of Hazardous Substances (RoHS) directive has come into force since 1st July 2006 all electronic products sold in the EU must be free of hazardous materials, such as lead. Inventek is fully committed to being one of the first to introduce lead-free products while maintaining backwards compatibility and focusing on a continuously high level of product and manufacturing quality.

**EMI/EMC:** The Inventek module design embeds EMI/EMC suppression features and accommodations to allow for higher operational reliability in noisier (RF) environments and easier integration compliance in host (OEM) applications.

**FCC/CE:** The module will be in compliance test for FCC/CE

## 17 Reflow Profile

- Reference the IPC/JEDEC standard.
- Peak Temperature:  $<250^{\circ}\text{C}$
- Number of Times:  $\leq 2$  times

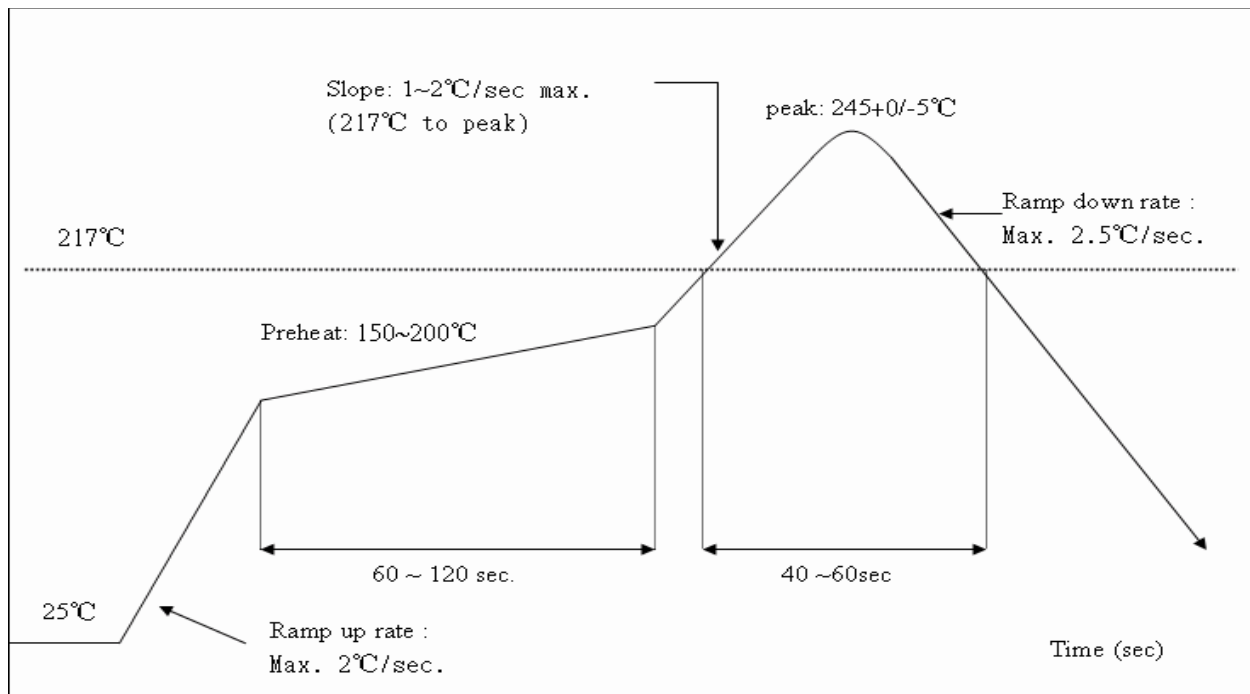

## 18 Packaging Information

### 18.1 MSL Level / Storage Condition

	<h3>Caution</h3> <p>This bag contains</p> <p><b>MOISTURE-SENSITIVE DEVICES</b></p> <p>Do not open except under controlled conditions</p>	<p>LEVEL</p> <div style="border: 1px solid black; padding: 5px; width: 40px; margin: 0 auto;"> <p style="font-size: 24px; margin: 0;">4</p> </div>
	<p>1. Calculated shelf life in sealed bag: 12 months at &lt;math&gt;&lt; 40^{\circ}\text{C}&lt;/math&gt; and &lt;math&gt;&lt; 90\%&lt;/math&gt; relative humidity (RH)</p> <p>2. Peak package body temperature:      <math>225^{\circ}\text{C}</math>   <math>240^{\circ}\text{C}</math>   <math>250^{\circ}\text{C}</math>   <math>260^{\circ}\text{C}</math></p> <p style="margin-left: 100px;"> <input type="checkbox"/>    <input type="checkbox"/>    <input checked="" type="checkbox"/>    <input type="checkbox"/> </p> <p>3. After bag is opened, devices that will be subjected to reflow solder or other high temperature process must</p> <p style="margin-left: 20px;">a) Mounted within: 48 hours of factory conditions &lt;math&gt;&lt; 30^{\circ}\text{C}/60\%&lt;/math&gt; RH, OR</p> <p style="margin-left: 20px;">b) Stored at &lt;math&gt;&lt; 10\%&lt;/math&gt; RH</p> <p>4. Devices require bake, before mounting, if:</p> <p style="margin-left: 20px;">a) Humidity Indicator Card is &gt;10% when read at <math>23 \pm 5^{\circ}\text{C}</math></p> <p style="margin-left: 20px;">b) 3a or 3b not met</p> <p>5. If baking is required, devices may be baked for 24 hours at <math>125 \pm 5^{\circ}\text{C}</math></p> <p>Note : If device containers cannot be subjected to high temperature or shorter bake times are desired, reference IPC/JEDEC J-STD-033 for bake procedure</p> <p>Bag Seal Date: <u>          <b>See-SEAL DATE LABEL</b>          </u></p> <p>Note: Level and body temperature defined by IPC/JEDEC J-STD-020</p>	

## ***18.2 Device baking requirements prior to assembly***

***Boards must be baked prior to rework or assembly to avoid damaging moisture sensitive components during localized reflow. The default bake cycles is 24 hours at 125C.***

Maintaining proper control of moisture uptake in components is critical.

Before opening the shipping bag and attempting solder reflow, you should maintain a minimal out-of-bag time and ensure the highest possible package reliability for the final product.

### ***Module's Assembly Instructions***

**Board Placement:** The ISM43362-M3G-L44 has an optional on board Wi-Fi antenna. The board is designed to be a stuffing option. If you elect to use the on-board antenna, then board placement is critical in your system. Several key items to consider when placing the module are:

- Ensure that the antenna portion of the design is placed so that the antenna has no ground plane under, above or near the antenna. Ideally, the antenna requires clear sky for optimal performance. If you have shields or other material around the antenna, please test for interference and loss of signal strength.

## 19 REVISION CONTROL

Document : ISM43362-M3G-L44	Wi-Fi module
External Release	DOC-DS-20023

Date	Author	Revision	Comment
8/15/2012	FMT	1.0	Preliminary
2/11/2013	FMT	1.1	Updated Ref. Schematic
5/5/2013	FMT	2.0	Updated SPI
7/24/13	FMT	2.1	Added FCC, updated Temperature ,SPI,UART
8/27/2013	FMT	3.0	Updated SPI information and reference schematic Update
9/18/2013	FMT	3.1	Update Ref Schematic
10/17/13	FMT	3.2	Footprint Updated

## 20 CONTACT INFORMATION

Inventek Systems  
 2 Republic Road  
 Billerica Ma, 01862  
 Tel: 978-667-1962  
[Sales@inventeksys.com](mailto:Sales@inventeksys.com)

[www.inventeksys.com](http://www.inventeksys.com)

Inventek Systems reserves the right to make changes without further notice to any products or data herein to improve reliability, function, or design. The information contained within is believed to be accurate and reliable. However Inventek Systems does not assume any liability arising out of the application or use of this information, nor the application or use of any product or circuit described herein, neither does it convey any license under its patent rights nor the rights of others.