

INCH-POUND

MIL-M-38510/350A

26 May 2004

SUPERSEDING

MIL-M-38510/350

24 June 1985

MILITARY SPECIFICATION

MICROCIRCUITS, DIGITAL, BIPOLAR, ADVANCED SCHOTTKY TTL,
QUAD 2-PORT REGISTERS, CASCADABLE, MONOLITHIC SILICON

Reactivated after 26 May 2004 and may be used for either new or existing design acquisition.

This specification is approved for use by all Departments
and Agencies of the Department of Defense.

The requirements for acquiring the product herein shall consist of this specification sheet and MIL-PRF 38535

1. SCOPE

1.1 Scope. This specification covers the detail requirements for monolithic silicon, advanced Schottky TTL, quad 2-port register microcircuits. Two product assurance classes and a choice of case outlines and lead finishes are provided for each type and are reflected in the complete part number. For this product, the requirements of MIL-M-38510 have been superseded by MIL-PRF-38535, (see 6.3).

1.2 Part or Identifying Number (PIN). The PIN is in accordance with MIL-PRF-38535, and as specified herein.

1.2.1 Device types. The device types are as follows:

<u>Device type</u>	<u>Circuit</u>
01	Quad 2-port cascadable register with both inverted and non-inverted outputs
02	Quad 2-port cascadable register with non-inverted outputs

1.2.2 Device class. The device class is the product assurance level as defined in MIL-PRF-38535.

1.2.3 Case outlines. The case outlines are as designated in MIL-STD-1835 and as follows:

<u>Outline letter</u>	<u>Descriptive designator</u>	<u>Terminals</u>	<u>Package style</u>
E	GDIP1-T16 or CDIP2-T16	16	Dual-in-line
F	GDFP2-F16 or CDFP3-F16	16	Flat pack
R	GDIP1-T20 or CDIP2-T20	20	Dual-in-line
S	GDFP2-F20 or CDFP3-F20	20	Flat pack
2	CQCC1-N20	20	Square leadless chip carrier

Comments, suggestions, or questions on this document should be addressed to: Commander, Defense Supply Center Columbus, ATTN: DSCC-VAS, P. O. Box 3990, Columbus, OH 43218-3990, or emailed to bipolar@dsccl.dla.mil. Since contact information can change, you may want to verify the currency of this address information using the ASSIST Online database at www.dodssp.daps.mil.

1.3 Absolute maximum ratings.

Supply voltage range	-0.5 V dc to +7.0 V dc
Input voltage range	-1.2 V dc at -18 mA to +7.0 V dc
Storage temperature range	-65° to +150°C
Maximum power dissipation, per device (P_D) ^{1/}	
Device type 01	209 mW
Device type 02	187 mW
Lead temperature (soldering, 10 seconds)	+300°C
Thermal resistance, junction to case (θ_{JC})	(See MIL-STD-1835)
Junction temperature (T_J) ^{2/}	175°C

1.4 Recommended operating conditions.

Supply voltage (V_{CC})	4.5 V dc minimum to 5.5 V dc maximum
Minimum high level input voltage (V_{IH})	2.0 V dc
Maximum low level input voltage (V_{IL})	0.8 V dc
Normalized fanout (each output) ^{3/} :	
Low level	33 maximum
High level	50 maximum
Case operating temperature range (T_C)	-55° to +125°C
Width of clock pulse high:	
Device type 01, 02	4.0 ns minimum
Width of clock pulse low:	
Device type 01, 02	7.0 ns minimum
Setup time in high to clock pulse:	
Device type 01, 02	4.5 ns minimum
Setup time in low to clock pulse:	
Device type 01, 02	4.5 ns minimum
Setup time S high to clock pulse:	
Device type 01	10.5 ns minimum
Device type 02	9.5 ns minimum
Setup time S low to clock pulse:	
Device type 01	10.5 ns minimum
Device type 02	9.5 ns minimum
Hold time in high to clock pulse:	
Device type 01, 02	1.5 ns minimum
Hold time in low to clock pulse:	
Device type 01, 02	1.5 ns minimum
Hold time S high to clock pulse:	
Device type 01, 02	0 ns minimum
Hold time S low to clock pulse:	
Device type 01, 02	0 ns minimum

2. APPLICABLE DOCUMENTS

2.1 General. The documents listed in this section are specified in sections 3, 4, or 5 of this specification. This section does not include documents cited in other sections of this specification or recommended for additional information or as examples. While every effort has been made to ensure the completeness of this list, document users are cautioned that they must meet all specified requirements of documents cited in sections 3, 4, or 5 of this specification, whether or not they are listed.

^{1/} Must withstand the added P_D due to short-circuit test (e.g., I_{OS}).

^{2/} Maximum junction temperature should not be exceeded except in accordance with allowable short duration burn-in screening condition in accordance with MIL-PRF-38535.

^{3/} The device should fanout in both high and low levels to specified number of inputs of the same device type as that being tested.

2.2 Government documents.

2.2.1 Specifications and Standards. The following specifications and standards form a part of this specification to the extent specified herein. Unless otherwise specified, the issues of these documents are those cited in the solicitation or contract.

DEPARTMENT OF DEFENSE SPECIFICATIONS

MIL-PRF-38535 - Integrated Circuits (Microcircuits) Manufacturing, General Specification for.

DEPARTMENT OF DEFENSE STANDARDS

MIL-STD-883 - Test Method Standard for Microelectronics.
MIL-STD-1835 - Interface Standard Electronic Component Case Outlines

(Copies of these documents are available online at <http://assist.daps.dla.mil/quicksearch/> or www.dodssp.daps.mil or from the Standardization Document Order Desk, 700 Robbins Avenue, Building 4D, Philadelphia, PA 19111-5094.)

2.3 Order of precedence. In the event of a conflict between the text of this specification and the references cited herein, the text of this document takes precedence. Nothing in this document, however, supersedes applicable laws and regulations unless a specific exemption has been obtained.

3. REQUIREMENTS

3.1 Qualification. Microcircuits furnished under this specification shall be products that are manufactured by a manufacturer authorized by the qualifying activity for listing on the applicable qualified manufacturers list before contract award (see 4.3 and 6.4).

3.2 Item requirements. The individual item requirements shall be in accordance with MIL-PRF-38535 and as specified herein or as modified in the device manufacturer's Quality Management (QM) plan. The modification in the QM plan shall not affect the form, fit, or function as described herein.

3.3 Design, construction, and physical dimensions. The design, construction, and physical dimensions shall be as specified in MIL-PRF-38535 and herein.

3.3.1 Terminal connections. The terminal connections shall be as specified on figure 1.

3.3.2 Truth tables. The truth tables shall be as specified on figure 2.

3.3.3 Logic diagrams. The logic diagrams shall be as specified on figure 3.

3.3.4 Schematic circuits. The schematic circuits shall be maintained by the manufacturer and made available to the qualifying activity and the preparing activity upon request.

3.3.3 Case outlines. The case outlines shall be as specified in 1.2.3.

3.4 Lead material and finish. The lead material and finish shall be in accordance with MIL-PRF-38535 (see 6.6).

3.5 Electrical performance characteristics. The electrical performance characteristics are as specified in table I, and apply over the full recommended case operating temperature range, unless otherwise specified.

3.6 Electrical test requirements. The electrical test requirements for each device class shall be the subgroups specified in table II. The electrical tests for each subgroup are described in table III.

3.7 Marking. Marking shall be in accordance with MIL-PRF-38535.

3.8 Microcircuit group assignment. The devices covered by this specification shall be in microcircuit group number 12 (see MIL-PRF-38535, appendix A).

4. VERIFICATION

4.1 Sampling and inspection. Sampling and inspection procedures shall be in accordance with MIL-PRF-38535 or as modified in the device manufacturer's Quality Management (QM) plan. The modification in the QM plan shall not effect the form, fit, or function as described herein.

4.2 Screening. Screening shall be in accordance with MIL-PRF-38535 and shall be conducted on all devices prior to qualification and conformance inspection. The following additional criteria shall apply:

- a. The burn-in test duration, test condition, and test temperature, or approved alternatives shall be as specified in the device manufacturer's QM plan in accordance with MIL-PRF-38535. The burn-in test circuit shall be maintained under document control by the device manufacturer's Technology Review Board (TRB) in accordance with MIL-PRF-38535 and shall be made available to the acquiring or preparing activity upon request. The test circuit shall specify the inputs, outputs, biases, and power dissipation, as applicable, in accordance with the intent specified in test method 1015 of MIL-STD-883.
- b. Interim and final electrical test parameters shall be as specified in table II, except interim electrical parameters test prior to burn-in is optional at the discretion of the manufacturer.
- c. Additional screening for space level product shall be as specified in MIL-PRF-38535.

4.3 Qualification inspection. Qualification inspection shall be in accordance with MIL-PRF-38535.

4.4 Technology Conformance inspection (TCI). Technology conformance inspection shall be in accordance with MIL-PRF-38535 and herein for groups A, B, C, and D inspections (see 4.4.1 through 4.4.4).

4.4.1 Group A inspection. Group A inspection shall be in accordance with table III of MIL-PRF-38535 and as follows:

- a. Tests shall be as specified in table II herein.
- b. Subgroups 4, 5, and 6 shall be omitted.

MIL-M-38510/350A

TABLE I. Electrical performance characteristics.

Test	Symbol	Conditions -55°C ≤ T _C ≤ +125°C unless otherwise specified	Device type	Limits		Unit
				Min	Max	
High level output voltage	V _{OH}	V _{CC} = 4.5 V, V _{IL} = 0.8 V, I _{OH} = -1.0 mA, V _{IH} = 2.0 V	All	2.5		V
Low level output voltage	V _{OL}	V _{CC} = 4.5 V, I _{OL} = 20 mA, V _{IH} = 2.0 V, V _{IL} = 0.8 V	All		0.5	V
Input clamp voltage	V _{IC}	V _{CC} = 4.5 V, I _{IN} = -18 mA, T _C = +25°C	All		-1.2	V
High level input current	I _{IH1}	V _{CC} = 5.5 V, V _{IN} = 2.7 V	All		20	μA
	I _{IH2}	V _{CC} = 5.5 V, V _{IN} = 7.0 V	All		100	μA
Low level input current	I _{IL}	V _{CC} = 5.5 V, V _{IN} = 0.5 V	All	-.03	-.60	mA
Short circuit output current <u>1/</u>	I _{OS}	V _{CC} = 5.5 V, V _{IN} = 0 V	All	-60	-150	mA
Output drive current	I _{OD}	V _{CC} = 4.5 V, V _{OUT} = 2.5 V V _{IN} = 5.5 V	All	60		mA
Supply current	I _{CC}	V _{CC} = 5.5 V, V _{IN} = GND	01		38	mA
			02		34	
Propagation delay time low to high level		V _{CC} = 5.0 V, C _L = 50 pF ± 10%, R _L = 500 Ω				
CP to Q, \bar{Q}	t _{PLH}		01	1.5	9.5	ns
CP to Q	t _{PLH}		02	1.5	9.5	ns
Propagation delay time high to low level						
CP to Q, \bar{Q}	t _{PHL}		01	1.5	11.5	ns
	t _{PHL}		02	1.5	11.5	ns
CP to Q						
Input clock frequency	f _{MAX}			All	80	

1/ Not more than one output should be shorted at a time.

TABLE II. Electrical test requirements.

MIL-PRF-38535 test requirements	Subgroups (see table III)	
	Class S devices	Class B devices
Interim electrical parameters	1	1
Final electrical test parameters	1*, 2, 3, 9,	1*, 2, 3, 7, 9
Group A test requirements	1, 2, 3, 7, 8, 9, 10, 11	1, 2, 3, 7, 8, 9, 10, 11
Group B electrical test parameters when using the method 5005 QCI option	1, 2, 3, 7, 8, 9, 10, 11	N/A
Group C end-point electrical parameters	1, 2, 3, 7, 8, 9, 10, 11	1, 2, 3
Group D end-point electrical parameters	1, 2, 3	1, 2, 3

*PDA applies to subgroup 1.

4.4.2 Group B inspection. Group B inspection shall be in accordance with table II of MIL-PRF-38535.

4.4.3 Group C inspection. Group C inspection shall be in accordance with table IV of MIL-PRF-38535 and as follows:

- a. End-point electrical parameters shall be as specified in table II herein.
- b. The steady-state life test duration, test condition, and test temperature, or approved alternatives shall be as specified in the device manufacturer's QM plan in accordance with MIL-PRF-38535. The burn-in test circuit shall be maintained under document control by the device manufacturer's Technology Review Board (TRB) in accordance with MIL-PRF-38535 and shall be made available to the acquiring or preparing activity upon request. The test circuit shall specify the inputs, outputs, biases, and power dissipation, as applicable, in accordance with the intent specified in test method 1005 of MIL-STD-883.

4.4.4 Group D inspection. Group D inspection shall be in accordance with table V of MIL-PRF-38535. End-point electrical parameters shall be as specified in table II herein.

4.5 Methods of inspection. Methods of inspection shall be specified as follows:

4.5.1 Voltage and current. All voltages given are referenced to the microcircuit ground terminal. Currents given are conventional and positive when flowing into the referenced terminal.

Terminal number	Device type 01	Device type 02	
	Cases R, S, and 2	Cases E and F	Case 2
1	S	S	N/C
2	QA	QA	S
3	\overline{QA}	I0A	QA
4	I0A	I1A	I0A
5	I1A	I1B	I1A
6	I1B	I0B	N/C
7	I0B	QB	I1B
8	\overline{QB}	GND	I0B
9	QB	CP	QB
10	GND	QC	GND
11	CP	I0C	N/C
12	QC	I1C	CP
13	\overline{QC}	I1D	QC
14	I0C	I0D	I0C
15	I1C	QD	I1C
16	I1D	V _{CC}	N/C
17	I0D		I1D
18	\overline{QD}		I0D
19	QD		QD
20	V _{CC}		V _{CC}

FIGURE 1. Terminal connections.

Device type 01

TRUTH TABLE EACH REGISTER				
INPUTS			OUTPUTS	
S	I0	I1	Q	\bar{Q}
l	l	X	L	H
l	h	X	H	L
h	X	l	L	H
h	X	h	H	L

l = Low voltage level one setup time prior to the low to high clock transition

h = High voltage level one setup time prior to the low to high clock transition

L = Low voltage level.

H = High voltage level.

X = Immaterial

Device type 02

TRUTH TABLE EACH REGISTER			
INPUTS			OUTPUTS
S	I0	I1	Q
l	l	X	L
l	h	X	H
h	X	l	L
h	X	h	H

l = Low voltage level one setup time prior to the low to high clock transition

h = High voltage level one setup time prior to the low to high clock transition

L = Low voltage level.

H = High voltage level.

X = Immaterial

FIGURE 2. Truth tables.

DEVICE TYPE 01

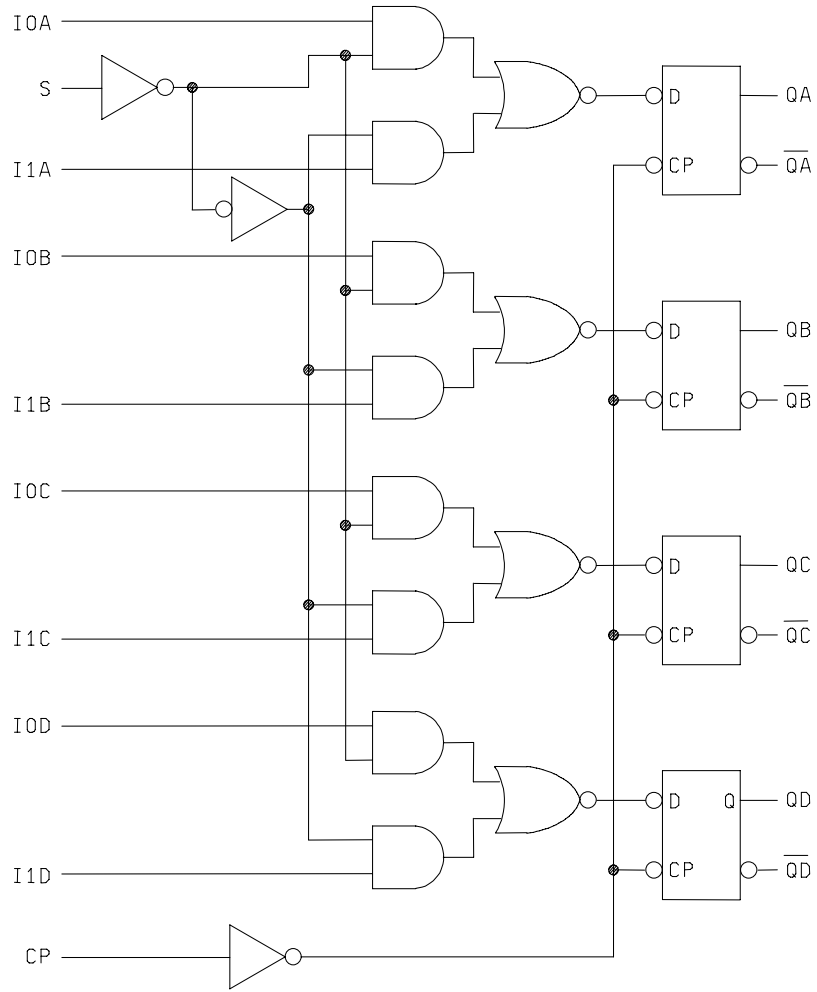

FIGURE 3. Logic diagram.

DEVICE TYPE 02

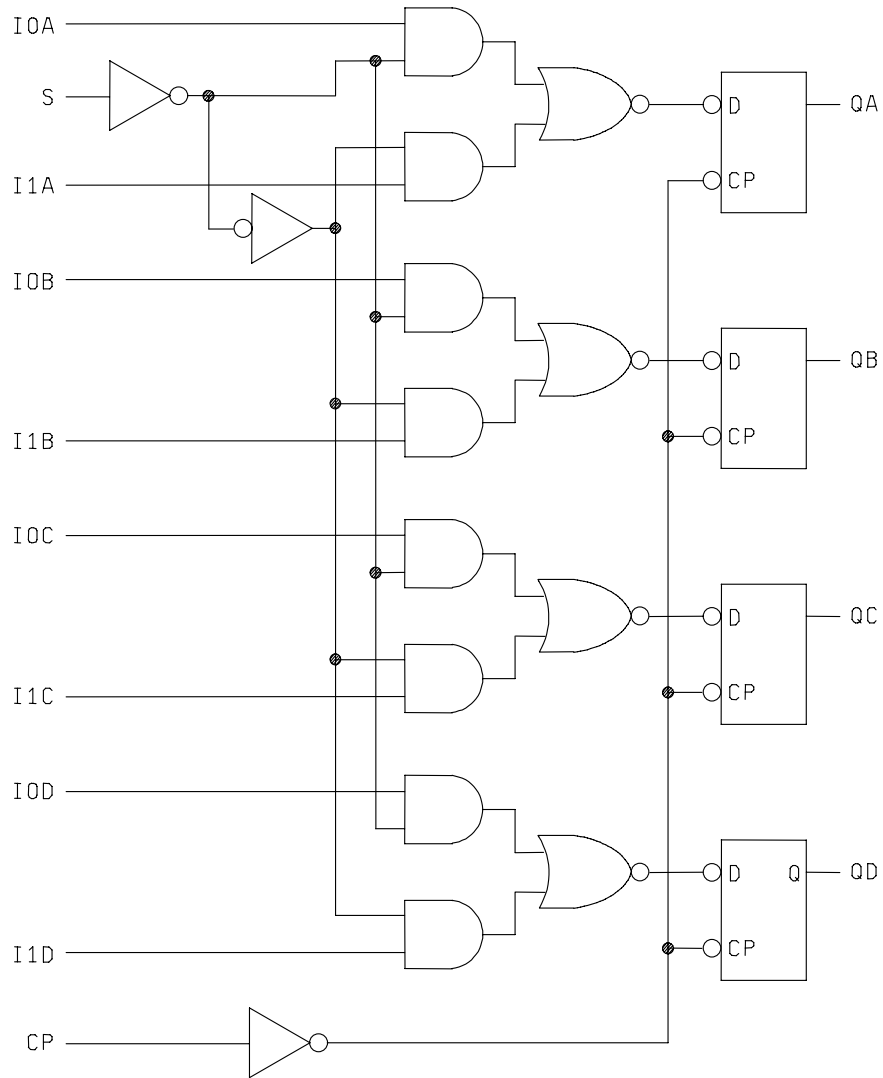

FIGURE 3. Logic diagram - Continued.

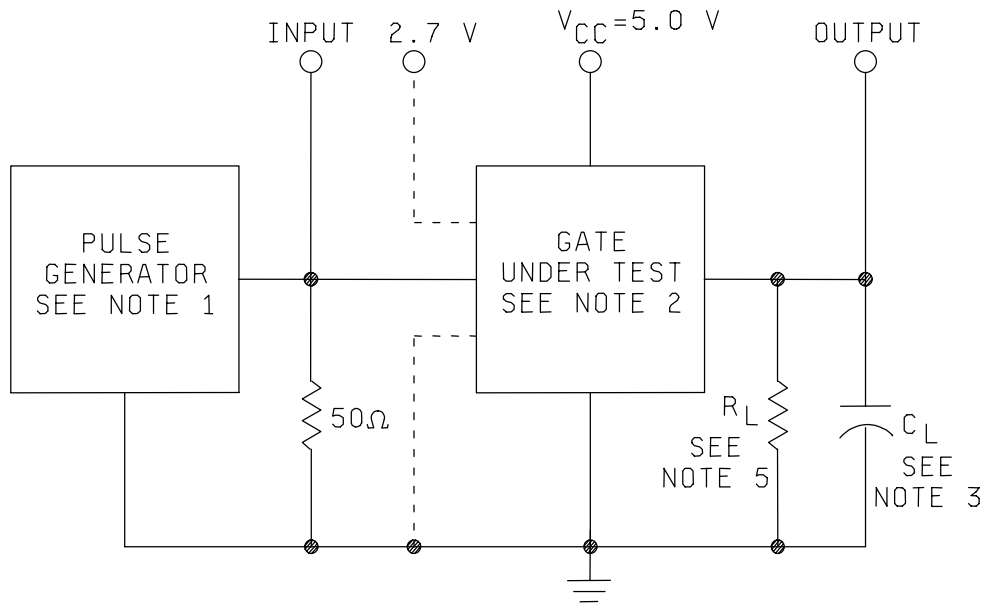
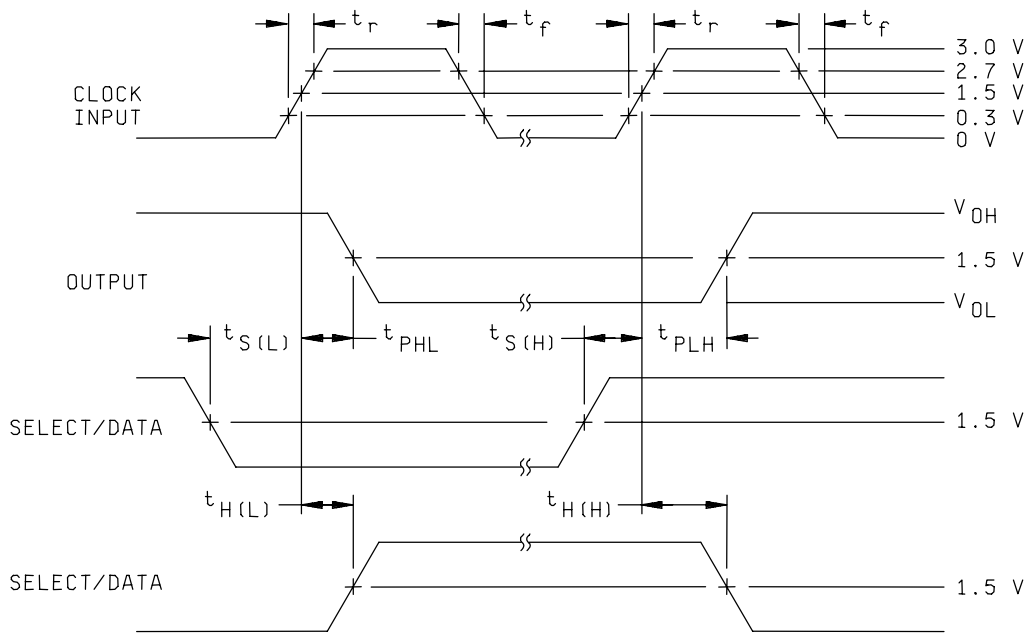

FIGURE 4. Switching test circuit.



NOTES:

1. Pulse generator has the following characteristics: $t_r = t_f \leq 2.5$ ns, $PRR \leq 1$ MHz, $Z_{OUT} \approx 50\Omega$.
2. Inputs not under test are at 2.7 V or GND as specified in table III.
3. $C_L = 50$ pF $\pm 10\%$, including scope, probe, wiring, and stray capacitance, without package in test fixture.
4. Voltage measurements are to be made with respect to network ground terminal.
5. $R_L = 500\Omega \pm 5\%$.
6. Setup and hold times, rising-edge clock for select input and data input.

FIGURE 4. Switching test circuit - Continued.

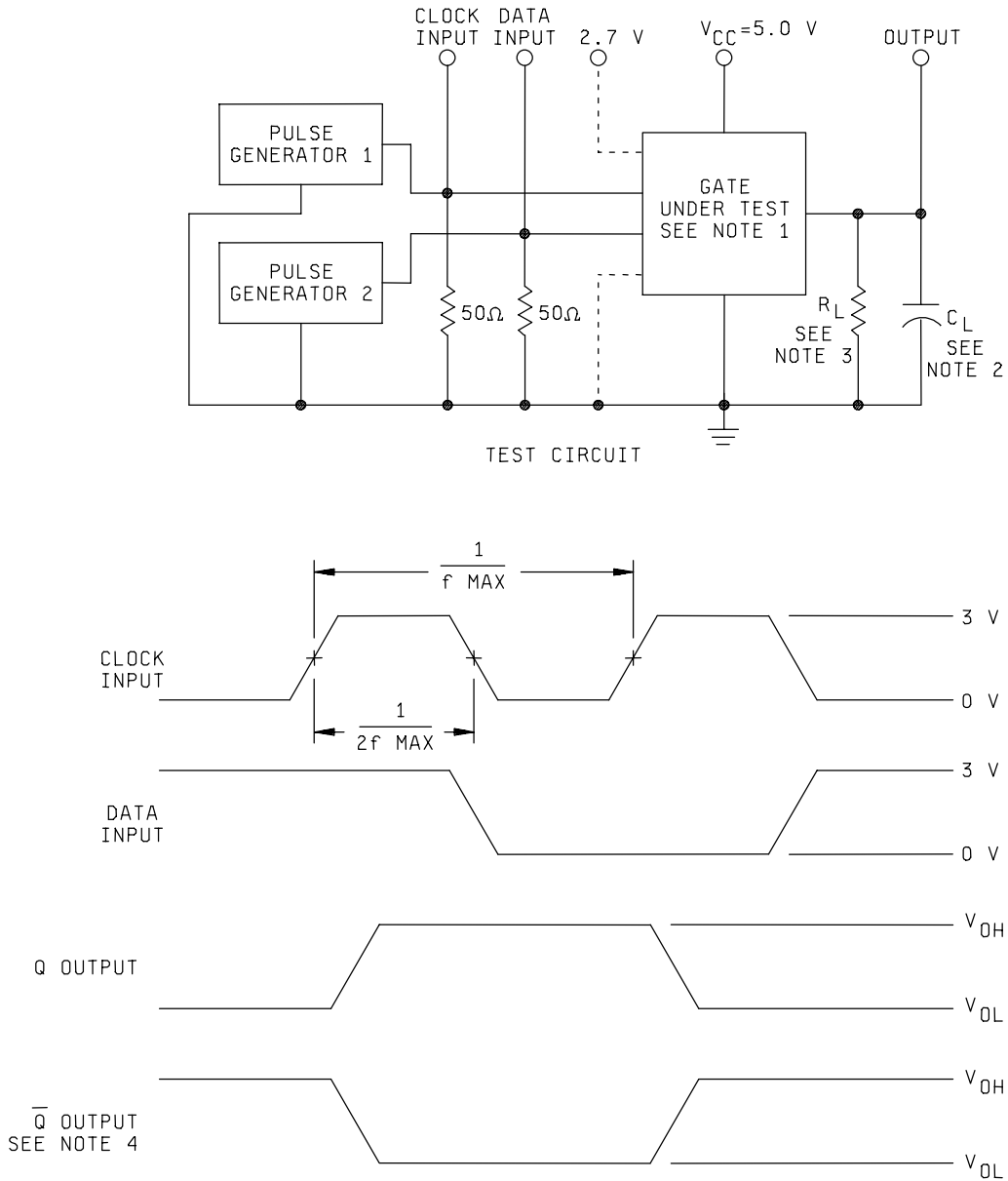

NOTES:

1. Inputs not under test are at 2.7 V or GND as specified in table III.
2. C_L = 50 pF ±10% including scope, probe, wiring, and stray capacitance, without package in test fixture.
3. R_L = 500Ω ±5%.
4. Device type 01 only.

FIGURE 5. Input clock frequency test circuit (all device types).

TABLE III. Group A inspection for device type 01.
Terminal conditions (pins not designated may be high ≥ 2.0 V; low ≤ 0.8 V; or open).

Subgroup	Symbol	MIL-STD-883 method	Cases R, S, 2 Test no.	1	2	3	4	5	6	7	8	9	10	11	12	13	14	15	16	17	18	19	20	Measured terminal	Test limits		Unit				
				S	QA	\overline{QA}	I0A	I1A	I1B	I0B	\overline{QB}	QB	GND	CP	QC	\overline{QC}	I0C	I1C	I1D	I0D	\overline{QD}	QD	V _{CC}		Min	Max					
1	V _{OH}	3006	1	0.8 V		-1 mA	0.8 V	5.5 V	5.5 V	5.5 V			GND	1/			5.5 V	5.5 V	5.5 V	5.5 V			4.5 V	\overline{QA}	2.5		V				
			2				0.0 V				0.8 V	-1 mA						5.5 V							\overline{QB}						
			3									0.0 V						-1 mA	0.8 V							\overline{QC}					
			4																0.0 V			0.8 V	-1 mA			\overline{QD}					
			5		-1 mA		2.0 V	0.0 V	0.0 V											0.0 V	0.0 V	0.0 V				QA					
			6				5.5 V					2.0 V		-1 mA													QB				
			7										5.5 V				-1 mA			2.0 V							QC				
			8																5.5 V			2.0 V		-1 mA			QD				
			9			2.0 V		-1 mA		0.8 V	5.5 V										5.5 V	5.5 V	5.5 V				\overline{QA}				
			10							0.0 V	0.8 V			-1 mA							5.5 V						\overline{QB}				
			11								0.0 V								-1 mA		0.8 V						\overline{QC}				
			12																		5.5 V	0.8 V		-1 mA			\overline{QD}				
			13				-1 mA			0.0 V	2.0 V	0.0 V								0.0 V	0.0 V	0.0 V	0.0 V				QA				
			14								5.5 V	2.0 V			-1 mA						0.0 V						QB				
			15									5.5 V									2.0 V						QC				
			16																		5.5 V	2.0 V			-1 mA		QD				
	17	V _{OL}	3007	17	0.8 V	20 mA		0.8 V			5.5 V							5.5 V	5.5 V	5.5 V	5.5 V				QA		0.5				
	18						0.0 V			0.8 V			20 mA						5.5 V							QB					
	19											0.0 V					20 mA			0.8 V							QC				
	20																			0.0 V			0.8 V		20 mA		QD				
	21						20 mA			2.0 V	0.0 V	0.0 V									0.0 V	0.0 V	0.0 V				QA				
	22									5.5 V			2.0 V	20 mA														QB			
	23												5.5 V						20 mA	2.0 V								QC			
	24																			5.5 V			2.0 V	20 mA			QD				
	25					2.0 V	20 mA			0.8 V	5.5 V										5.5 V	5.5 V	5.5 V				QA				
	26									0.0 V	0.8 V				20 mA						5.5 V							QB			
	27										0.0 V							20 mA			0.8 V							QC			
	28																				0.0 V	0.8 V			20 mA		QD				
	29						20 mA			0.0 V	2.0 V		0.0 V							0.0 V		0.0 V	0.0 V					QA			
	30										5.5 V	2.0 V		20 mA														QB			
	31											5.5 V								20 mA		2.0 V						QC			
	32											5.5 V									5.5 V	2.0 V		20 mA				QD			
	33	V _{IC}		33	-18 mA																				S	-1.2					
	34						-18 mA																			I0A					
	35								-18 mA																		I1A				
	36										-18 mA																	I1B			
	37												-18 mA															I0B			
	38																-18 mA											CP			
	39																			-18 mA								I0C			
	40																				-18 mA							I1C			
	41																					-18 mA						I1D			
	42																						-18 mA					I0D			

See footnotes at end of device type 01.

TABLE III. Group A inspection for device type 01.
Terminal conditions (pins not designated may be high ≥ 2.0 V; low ≤ 0.8 V; or open).

Subgroup	Symbol	MIL-STD-883 method	Cases R, S, 2	1	2	3	4	5	6	7	8	9	10	11	12	13	14	15	16	17	18	19	20	Measured terminal	Test limits		Unit										
																									Test no.	S		QA	\overline{QA}	I0A	I1A	I1B	I0B	\overline{QB}	QB	GND	CP
1 T _c = 25°C	I _{IH1}	3010	43	2.7 V																				5.5 V	S		20	μA									
			44				2.7 V																														
			45	0.0 V				2.7 V																													
			46	0.0 V						2.7 V																											
			47								2.7 V																										
			48									2.7 V																									
			49													2.7 V																					
			50	0.0 V																																	
			51	0.0 V																																	
			52																																		
			53	7.0 V																																	
			54						7.0 V																												
			55	0.0 V						7.0 V																											
	56	0.0 V							7.0 V																												
	57									7.0 V																											
	58										7.0 V																										
	59																																				
	60	0.0 V																																			
	61	0.0 V																																			
	62																																				
	63	0.5 V																																			
	64	0.0 V						0.5 V																													
	65	5.5 V							0.5 V																												
	66	5.5 V								0.5 V																											
	67	0.0 V									0.5 V																										
	68	5.5 V										0.5 V																									
	69	0.0 V																																			
	70	5.5 V																																			
	71	5.5 V																																			
	72	0.0 V																																			
	73				0.0 V			5.5 V	5.5 V						1/																						
	74					0.0 V		0.0 V	0.0 V																												
	75									0.0 V	0.0 V	0.0 V																									
	76									5.5 V	5.5 V		0.0 V																								
	77														0.0 V			5.5 V	5.5 V																		
	78															0.0 V	0.0 V	0.0 V																			
	79																				0.0 V	0.0 V	0.0 V														
	80																				5.5 V	5.5 V															
	81				2.5 V			0.0 V	0.0 V																												
	82					2.5 V		5.5 V	5.5 V																												
	83									5.5 V	5.5 V	2.5 V																									
	84									0.0 V	0.0 V		2.5 V																								
	85																																				
	86																	2.5 V	2.5 V	0.0 V	0.0 V																
	87																																				
	88																																				
	89							5.5 V	5.5 V	5.5 V	5.5 V							5.5 V	5.5 V	0.0 V	0.0 V																
	I _{CC}		3006																																		
	2	Same tests, terminal conditions, and limits as subgroup 1, except T _c = +125°C and V _{Ic} tests are omitted.																																			
	3	Same tests, terminal conditions, and limits as subgroup 1, except T _c = -55°C and V _{Ic} tests are omitted.																																			

See footnotes at end of device type 01.

TABLE III. Group A inspection for device type 01.
Terminal conditions (pins not designated may be high ≥ 2.0 V; low ≤ 0.8 V; or open).

Subgroup	Symbol	MIL-STD-883 method	Cases R, S, 2 Test no.	1	2	3	4	5	6	7	8	9	10	11	12	13	14	15	16	17	18	19	20	Measured terminal	Test limits		Unit					
				S	QA	\overline{QA}	I0A	I1A	I1B	I0B	\overline{QB}	QB	GND	CP	QC	\overline{QC}	I0C	I1C	I1D	I0D	\overline{QD}	QD	V _{CC}		Min	Max						
7 T _c = 25°C	Functional tests 3/	3014	90	B		\overline{QA}	B	A	A	B	\overline{QB}		GND	B			B	A	A	B	\overline{QD}			2/								
			91	"	L	H	"	"	"	"	"	H	L	"	A	L	H	"	"	"	"	H	L	"								
			92	"	"	"	"	"	"	"	"	"	"	"	"	B	"	"	"	"	"	"	"	"	"							
			93	"	"	"	"	A	B	"	"	"	"	"	"	B	"	"	"	"	"	"	"	"	"							
			94	"	H	L	"	"	"	"	"	"	"	"	"	A	"	"	"	"	"	"	"	"	"							
			95	"	"	"	"	"	"	"	"	"	"	"	"	B	"	"	"	"	"	"	"	"	"							
			96	"	"	"	"	B	A	B	A	"	"	"	"	B	"	"	"	"	"	"	"	"	"							
			97	"	L	H	"	"	"	"	"	"	"	"	"	A	"	"	"	"	"	"	"	"	"							
			98	"	"	"	"	"	"	"	"	"	"	"	"	B	"	"	"	"	"	"	"	"	"							
			99	"	"	"	"	"	"	"	A	B	"	"	"	B	"	"	A	B	"	"	"	"	"							
			100	"	"	"	"	"	"	"	"	"	H	L	"	A	H	L	"	"	"	"	"	"	"							
			101	"	"	"	"	"	"	"	"	"	"	"	"	B	"	"	"	"	"	"	"	"	"							
			102	"	"	"	"	"	"	"	"	"	"	"	"	B	"	"	"	B	A	B	A	"	"							
			103	"	"	"	"	"	"	"	"	"	"	"	"	A	L	H	"	"	"	"	"	L	H	"						
			104	"	"	"	"	"	"	"	"	"	"	"	"	B	"	"	"	"	"	"	"	"	"							
			105	"	"	"	"	"	"	"	"	"	"	"	"	B	"	"	"	"	A	B	"	"	"							
			106	"	"	"	"	"	"	"	"	"	"	"	"	A	"	"	"	"	"	"	"	H	L	"						
			107	"	"	"	"	"	"	"	"	"	"	"	"	B	"	"	"	"	"	"	"	"	"							
			108	"	A	"	"	"	"	"	"	"	"	"	"	B	"	"	"	"	"	"	"	"	"							
			109	"	"	H	L	"	"	"	"	"	"	L	H	"	A	H	L	"	"	"	"	L	H	"						
			110	"	"	"	"	"	"	"	"	"	"	"	"	B	"	"	"	"	"	"	"	"	"							
			111	"	"	"	"	A	B	B	A	"	"	"	"	B	"	"	"	A	B	B	A	"	"							
			112	"	L	H	A	"	B	A	H	L	"	"	"	A	L	H	"	A	B	B	A	H	L	"						
			113	"	"	"	"	B	A	A	B	"	"	"	"	A	"	"	"	B	A	A	B	"	"							
			114	"	"	"	"	"	"	"	"	"	"	"	"	B	"	"	"	"	"	"	"	"	"							
115	"	"	H	L	"	"	"	"	"	"	L	H	"	A	H	L	"	"	"	"	"	"										
116	"	"	"	"	A	B	B	A	"	"	"	"	A	"	"	"	A	B	B	A	"	"										
117	"	"	"	"	"	"	"	"	"	"	"	"	B	"	"	"	"	"	"	"	"	"										
118	"	"	L	H	"	"	"	"	"	"	H	L	"	A	L	H	"	"	"	"	"	"										
119	"	B	"	"	"	"	"	"	"	"	"	"	A	"	"	"	"	"	"	"	"	"										
120	"	"	"	"	"	"	"	"	"	"	"	"	B	"	"	"	"	"	"	"	"	"										
121	"	"	H	L	"	"	"	"	"	"	L	H	"	A	H	L	"	"	"	"	"	"										
122	"	"	"	"	B	A	A	B	"	"	"	"	A	"	"	"	B	A	A	B	"	"										
123	"	"	"	"	"	"	"	"	"	"	"	"	B	"	"	"	"	"	"	"	"	"										
124	"	"	L	H	"	"	"	"	"	"	H	L	"	A	L	H	"	"	"	"	"	"										
125	"	"	L	H	"	"	"	"	"	"	H	L	"	B	L	H	"	"	"	"	"	"										
8	Same tests, terminal conditions, and limits as for subgroup 7, except T _c = +125°C and T _c = -55°C.																															
9 T _c = 25°C	t _{PLH}	3003 Fig. 4	126	0.0 V	OUT		2.7 V	0.0 V	0.0 V	0.0 V			GND	IN				0.0 V	0.0 V	0.0 V	0.0 V			5.0 V	QA	1.5	7.5	ns				
			127	"	"	OUT		0.0 V	"	"	0.0 V	"	"	"	"	"	"	"	"	"	"	"	"	"	"	"	\overline{QA}	"	"	"		
			128	"	"	"	"	"	"	"	"	2.7 V	"	OUT	"	"	"	"	"	"	"	"	"	"	"	"	"	QB	"	"	"	
			129	"	"	"	"	"	"	"	"	0.0 V	"	OUT	"	"	"	"	"	"	"	"	"	"	"	"	"	\overline{QB}	"	"	"	
			130	"	"	"	"	"	"	"	"	"	"	"	"	"	"	OUT	"	2.7 V	"	"	"	"	"	"	"	QC	"	"	"	
			131	"	"	"	"	"	"	"	"	"	"	"	"	"	"	"	OUT	0.0 V	"	"	"	"	"	"	"	\overline{QC}	"	"	"	
			132	"	"	"	"	"	"	"	"	"	"	"	"	"	"	"	"	"	"	"	2.7 V	"	OUT	"	"	QD	"	"	"	
			133	"	"	"	"	"	"	"	"	"	"	"	"	"	"	"	"	"	"	"	0.0 V	"	OUT	"	"	\overline{QD}	"	"	"	
			134	"	2.7 V	OUT	"	"	2.7 V	"	"	"	"	"	"	"	"	"	"	"	"	"	"	0.0 V	"	"	"	QA	"	"	"	
			135	"	"	"	OUT	"	0.0 V	"	"	"	"	"	"	"	"	"	"	"	"	"	"	"	"	"	"	\overline{QA}	"	"	"	
			136	"	"	"	"	"	"	2.7 V	"	"	"	"	OUT	"	"	"	"	"	"	"	"	"	"	"	"	"	QB	"	"	"
			137	"	"	"	"	"	"	0.0 V	"	"	"	OUT	"	"	"	"	"	"	"	"	"	"	"	"	"	"	\overline{QB}	"	"	"
			138	"	"	"	"	"	"	"	"	"	"	"	"	"	"	OUT	"	"	2.7 V	"	"	"	"	"	"	"	QC	"	"	"
			139	"	"	"	"	"	"	"	"	"	"	"	"	"	"	"	OUT	"	0.0 V	"	"	"	"	"	"	"	\overline{QC}	"	"	"
			140	"	"	"	"	"	"	"	"	"	"	"	"	"	"	"	"	"	"	2.7 V	"	"	OUT	"	"	"	QD	"	"	"
141	"	"	"	"	"	2.7 V	"	"	"	"	"	"	"	"	"	"	"	"	0.0 V	"	"	OUT	"	"	"	\overline{QD}	"	"	"			

See footnotes at end of device type 01.

TABLE III. Group A inspection for device type 01.
Terminal conditions (pins not designated may be high ≥ 2.0 V; low ≤ 0.8 V; or open).

Subgroup	Symbol	MIL-STD-883 method	Cases R, S, 2	1	2	3	4	5	6	7	8	9	10	11	12	13	14	15	16	17	18	19	20	Measured terminal	Test limits		Unit		
																									S	QA		\overline{QA}	I0A
9 T _c = 25°C	f _{PHL}	3003 Fig. 4	142	0.0 V	OUT		0.0 V	0.0 V	0.0 V	2.7 V			GND	IN			2.7 V	0.0 V	0.0 V	2.7 V			5.0 V	QA	1.5	9.5	ns		
			143	"		OUT	2.7 V	"	"	2.7 V				"	"			"	"	"	"			"	\overline{QA}	"	"	"	
			144	"			"	"	"	0.0 V			OUT	"	"			"	"	"	"			"	QB	"	"	"	
			145	"			"	"	"	2.7 V		OUT	"	"				"	"	"	"			"	QB	"	"	"	
			146	"			"	"	"	"	"					OUT		0.0 V	"	"	"			"	QC	"	"	"	
			147	"			"	"	"	"	"						OUT	2.7 V	"	"	"			"	\overline{QC}	"	"	"	
			148	"			"	"	"	"	"					"	"	"	"	"	0.0 V		OUT	"	QD	"	"	"	
			149	"			"	"	"	"	"					"	"	"	"	"	2.7 V		OUT	"	QD	"	"	"	
			150	2.7 V	OUT		0.0 V	"	2.7 V	0.0 V						"	"		0.0 V	2.7 V	2.7 V	0.0 V			"	QA	"	"	"
			151	"		OUT		2.7 V	2.7 V							"	"		"	"	"	"			"	QA	"	"	"
			152	"			"	"	0.0 V	"			OUT	"	"			"	"	"	"	"			"	QB	"	"	"
			153	"			"	"	2.7 V	"			OUT	"	"			"	"	"	"	"			"	\overline{QB}	"	"	"
			154	"			"	"	"	"	"					OUT		"	0.0 V	"	"	"			"	QC	"	"	"
			155	"			"	"	"	"	"						OUT	"	2.7 V	"	"	"			"	QC	"	"	"
			156	"			"	"	"	"	"							"	"	0.0 V	"	"		OUT	"	QD	"	"	"
			157	"			"	"	"	"	"							"	"	2.7 V	"	"		OUT	"	QD	"	"	"
			10	f _{MAX} 5/	3003 Fig. 5	158	0.0 V	OUT		IN2	0.0 V	0.0 V	"				IN1			"	0.0 V	0.0 V	"			5.0 V	QA	100	
159	"					OUT	IN2	"	"	"					"	"		"	"	"	"			"	\overline{QA}	"	"	"	
160	"						0.0 V	"	"	IN2	OUT				"	"		"	"	"	"			"	QB	"	"	"	
161	"						"	"	"	IN2		OUT	"	"				"	"	"	"	"			"	QB	"	"	"
162	"						"	"	"	0.0 V					OUT			IN2	"	"	"	"			"	QC	"	"	"
163	"						"	"	"	"	"						OUT	IN2	"	"	"	"			"	QC	"	"	"
164	"						"	"	"	"	"							0.0 V	"	"	IN2	OUT			"	QD	"	"	"
165	"						"	"	"	"	"							"	"	"	IN2		OUT		"	QD	"	"	"
166	2.7 V	OUT					"	IN2	"	"	"	"						"	"	"	"	0.0 V			"	QA	"	"	"
167	"					OUT		IN2	"	"	"	"						"	"	"	"	"			"	QA	"	"	"
168	"						"	0.0 V	IN2	"	OUT							"	"	"	"	"			"	QB	"	"	"
169	"			"	"	IN2	"			OUT	"	"			"	"	"	"	"			"	QB	"	"	"			
170	"			"	"	0.0 V	"						OUT		"	IN2	"	"	"			"	QC	"	"	"			
171	"			"	"	"	"	"						OUT	"	IN2	"	"	"			"	\overline{QC}	"	"	"			
172	"			"	"	"	"	"							"	0.0 V	IN2	"	OUT			"	QD	"	"	"			
173	"			"	"	"	"	"							"	0.0 V	IN2	"			OUT	"	QD	"	"	"			
10	Same tests as subgroup 9, except T _c = +125°C and use limits from table I.																												
11	Same tests as subgroup 9, except T _c = -55°C and use limits from table I.																												

- 1/ Apply all voltages, then apply 3.0 V, 0.0 V, 3.0 V to CP then make measurement.
- 2/ Perform function sequence at V_{CC} = 4.5 V and repeat at V_{CC} = 5.5 V.
- 3/ A = 3.0 V, B = 0.0 V or GND; H > 1.5 V, L < 1.5 V.
- 4/ I_{IL} limits (mA) min/max values for circuit shown:

Test	Min/Max limits in mA		
	CKT A	B	C
I _{IL}	-.25/-.60	-.03/-.60	

- 5/ f_{MAX} shall be measured only under the conditions of initial qualification and after process or design changes which may affect this parameter. For all other conditions, f_{MAX} shall be guaranteed, if not tested, to the limits specified in table III, herein.

TABLE III. Group A inspection for device type 02.
Terminal conditions (pins not designated may be high ≥ 2.0 V; low ≤ 0.8 V; or open).

Subgroup	Symbol	MIL-STD-883 method	Cases E, F	1	2	3	4	5	6	7	8	9	10	11	12	13	14	15	16	Measured terminal	Limits		Unit				
			Case 2 1/	2	3	4	5	7	8	9	10	12	13	14	15	17	18	19	20		Min	Max					
			Test no.	S	QA	I0A	I1A	I1B	I0B	QB	GND	CP	QC	I0C	I1C	I1D	I0D	QD	V _{CC}								
1 Tc = 25°C	V _{OH}	3006	1	0.8 V	-1 mA	2.0 V	0.8 V													4.5 V	QA	2.5		V			
			2	2.0 V	-1 mA	0.8 V	2.0 V																QA				
			3	0.8 V				0.8 V	2.0 V	-1 mA														QB			
			4	2.0 V				2.0 V	0.8 V	-1 mA														QB			
			5	0.8 V																				QC			
			6	2.0 V											-1 mA	2.0 V	0.8 V							QC			
			7	0.8 V																				QD			
			8	2.0 V														0.8 V	2.0 V	-1 mA				QD			
	V _{OL}	3007	9	0.8 V	20 mA	0.8 V	2.0 V																QA		0.5		
			10	2.0 V	20 mA	2.0 V	0.8 V																	QA			
			11	0.8 V				2.0 V	0.8 V	20 mA														QB			
			12	2.0 V				0.8 V	2.0 V	20 mA														QB			
			13	0.8 V											20 mA	0.8 V	2.0 V							QC			
			14	2.0 V											20 mA	2.0 V	0.8 V							QC			
			15	0.8 V														2.0 V	0.8 V	20 mA				QD			
			16	2.0 V														0.8 V	2.0 V	20 mA				QD			
	V _{Ic}		17	-18 mA																			S		-1.2		
			18			-18 mA																		I0A			
			19				-18 mA																	I1A			
			20					-18 mA																I1B			
			21						-18 mA															I0B			
			22							-18 mA														CP			
			23									-18 mA												I0C			
			24												-18 mA									I1C			
			25														-18 mA							I1D			
			26																-18 mA					I0D			
	I _{IH1}	3010	27	2.7 V																	5.5 V		S		20	μA	
			28			2.7 V																		I0A			
			29	0.0 V			2.7 V																	I1A			
			30	0.0 V				2.7 V																I1B			
			31						2.7 V															I0B			
			32										2.7 V											CP			
			33												2.7 V									I0C			
			34	0.0 V													2.7 V							I1C			
			35	0.0 V														2.7 V						I1D			
			36																	2.7 V				I0D			
	I _{IH2}		37	7.0 V																			S		100		
			38			7.0 V																		I0A			
			39	0.0 V			7.0 V																	I1A			
			40	0.0 V				7.0 V																I1B			
			41						7.0 V															I0B			
			42										7.0 V											CP			
			43												7.0 V									I0C			
			44	0.0 V													7.0 V							I1C			
			45	0.0 V														7.0 V						I1D			
			46																	7.0 V				I0D			
	I _{IL}	3009	47	0.5 V																			S	5/	5/	mA	
			48	0.0 V		0.5 V																		I0A			
			49	5.5 V			0.5 V																	I1A			
			50	5.5 V				0.5 V																I1B			
			51	0.0 V					0.5 V		0.5 V													I0B			
			52	5.5 V										0.5 V										CP			
			53	0.0 V											0.5 V									I0C			
			54	5.5 V												0.5 V								I1C			
			55	5.5 V													0.5 V							I1D			
			56	0.0 V														0.5 V						I0D			

See footnotes at end of device type 02.

TABLE III. Group A inspection for device type 02.
Terminal conditions (pins not designated may be high ≥ 2.0 V; low ≤ 0.8 V; or open).

Subgroup	Symbol	MIL-STD-883 method	Cases E, F	1	2	3	4	5	6	7	8	9	10	11	12	13	14	15	16	Measured terminal	Limits		Unit					
			Case 2 1/	2	3	4	5	7	8	9	10	12	13	14	15	17	18	19	20		V _{CC}	Min		Max				
			Test no.	S	QA	I0A	I1A	I1B	I0B	QB	GND	CP	QC	I0C	I1C	I1D	I0D	QD										
1	T _c = 25°C	I _{OS}	3011	57	0.0 V	5.5 V	5.5 V													5.5 V	QA	-60	-150	mA				
			"	58					5.5 V	5.5 V	0.0 V	"	"								"	QB	"	"	"			
			"	59										0.0 V	5.5 V	5.5 V					"	QC	"	"	"			
			"	60													5.5 V	5.5 V	0.0 V		"	QD	"	"	"			
			I _{OD}	61	2.5 V	0.0 V	0.0 V															4.5 V	QA	60		"		
				62					0.0 V	0.0 V	2.5 V	"	"										"	QB	"	"	"	
	63												2.5 V	0.0 V	0.0 V					"	QC	"	"	"				
	64														0.0 V	0.0 V	2.5 V			"	QD	"	"	"				
	I _{CC}	3005	65		5.5 V	5.5 V	5.5 V	5.5 V	"	"				5.5 V	5.5 V	5.5 V	5.5 V	5.5 V	5.5 V	V _{CC}			34	"				
	2	Same tests, terminal conditions, and limits as subgroup 1, except T _c = +125°C and V _{IC} tests are omitted.																										
3	Same tests, terminal conditions, and limits as subgroup 1, except T _c = -55°C and V _{IC} tests are omitted.																											
7	T _c = 25°C	Functional test 4/	3014	66	B	B	A	A	B		GND	B		B	A	A	B			3/								
				67	"	L	"	"	"	"	"	"	"	A	L	"	"	"	"	"	"	"	"	"	"	"		
				68	"	"	"	"	"	"	"	"	"	"	"	"	"	"	"	"	"	"	"	"	"	"	"	
				69	"	"	A	B	"	"	"	"	"	B	"	"	"	"	"	"	"	"	"	"	"	"	"	
				70	"	H	"	"	"	"	"	"	"	A	"	"	"	"	"	"	"	"	"	"	"	"	"	
				71	"	"	"	"	"	"	"	"	"	B	"	"	"	"	"	"	"	"	"	"	"	"	"	
				72	"	"	B	A	B	A	"	"	"	B	"	"	"	"	"	"	"	"	"	"	"	"	"	
				73	"	L	"	"	"	"	"	"	"	A	"	"	"	"	"	"	"	"	"	"	"	"	"	"
				74	"	"	"	"	"	"	"	"	"	B	"	"	"	"	"	"	"	"	"	"	"	"	"	"
				75	"	"	"	"	"	A	B	"	"	B	"	"	A	B	"	"	"	"	"	"	"	"	"	"
				76	"	"	"	"	"	"	"	"	"	A	H	"	"	"	"	"	"	"	"	"	"	"	"	"
				77	"	"	"	"	"	"	"	"	"	"	B	"	"	"	"	"	"	"	"	"	"	"	"	"
				78	"	"	"	"	"	"	"	"	"	"	B	"	B	A	B	A	"	"	"	"	"	"	"	"
				79	"	"	"	"	"	"	"	"	"	"	A	L	"	"	"	"	"	"	"	"	H	"	"	"
				80	"	"	"	"	"	"	"	"	"	"	B	"	"	"	"	"	"	"	"	"	"	"	"	"
				81	"	"	"	"	"	"	"	"	"	"	B	"	"	"	A	B	"	"	"	"	"	"	"	"
				82	"	"	"	"	"	"	"	"	"	"	A	"	"	"	"	"	"	"	"	"	"	L	"	"
				83	"	"	"	"	"	"	"	"	"	"	B	"	"	"	"	"	"	"	"	"	"	"	"	"
				84	A	"	"	"	"	"	"	"	"	"	B	"	"	"	"	"	"	"	"	"	"	"	"	"
				85	"	H	"	"	"	"	"	"	"	"	A	H	"	"	"	"	"	"	"	"	"	H	"	"
				86	"	"	"	"	"	"	"	"	"	"	B	"	"	"	"	"	"	"	"	"	"	"	"	"
87	"	"	A	B	B	A	"	"	"	"	B	"	A	B	B	A	"	"	"	"	"	"	"	"				
88	"	L	A	B	B	A	L	"	"	"	A	L	A	B	B	A	L	"	"	"	"	"	"	"				
89	"	"	B	A	A	B	"	"	"	"	A	"	B	A	A	B	"	"	"	"	"	"	"	"				
90	"	"	"	"	"	"	"	"	"	"	B	"	"	"	"	"	"	"	"	"	"	"	"	"				
91	"	"	H	"	"	"	"	"	"	"	A	H	"	"	"	"	"	"	"	"	"	H	"	"				
92	"	"	A	B	B	A	H	"	"	"	A	"	A	B	B	A	"	"	"	"	"	"	"	"				
93	"	"	"	"	"	"	"	"	"	"	"	"	"	"	"	"	"	"	"	"	"	"	"	"				
94	"	L	"	"	"	"	"	"	"	"	A	L	"	"	"	"	"	"	"	"	"	L	"	"				
95	B	"	"	"	"	"	"	"	"	"	A	"	"	"	"	"	"	"	"	"	"	"	"	"				
96	"	"	"	"	"	"	"	"	"	"	B	"	"	"	"	"	"	"	"	"	"	"	"	"				
97	"	"	H	"	"	"	"	"	"	"	A	H	"	"	"	"	"	"	"	"	"	"	H	"				
98	"	"	B	A	A	B	"	"	"	"	A	"	B	A	A	B	"	"	"	"	"	"	"	"				
99	"	"	"	"	"	"	"	"	"	"	"	"	"	"	"	"	"	"	"	"	"	"	"	"				
100	"	"	L	"	"	"	"	"	"	"	A	L	"	"	"	"	"	"	"	"	"	L	"	"				
101	"	"	L	"	"	"	"	"	"	"	B	L	"	"	"	"	"	"	"	"	"	L	"	"				
8	Same tests, terminal conditions, and limits as for subgroup 7, except T _c = +125°C and T _c = -55°C.																											

See footnotes at end of device type 02.

TABLE III. Group A inspection for device type 02.
Terminal conditions (pins not designated may be high ≥ 2.0 V; low ≤ 0.8 V; or open).

Subgroup	Symbol	MIL-STD-883 method	Cases E, F																Measured terminal	Limits		Unit			
			1	2	3	4	5	6	7	8	9	10	11	12	13	14	15	16		Min	Max				
			Case 2 1/	2	3	4	5	7	8	9	10	12	13	14	15	17	18	19		20					
9 T _c = 25°C	t _{PLH}	3004 Fig. 4	Test no.	S	QA	I0A	I1A	I1B	I0B	QB	GND	CP	QC	I0C	I1C	I1D	I0D	QD	V _{CC}	QA	Min	Max	ns		
			102	0.0 V	OUT	2.7 V	0.0 V	0.0 V	0.0 V	2.7 V	OUT	"	"	"	0.0 V	0.0 V	0.0 V	0.0 V	"	5.0 V	"	1.5	7.5	"	
			103	"	"	"	"	"	"	"	"	"	"	OUT	2.7 V	"	"	"	"	"	"	QB	"	"	"
			104	"	"	"	"	"	"	"	"	"	"	"	2.7 V	"	"	"	"	"	"	QC	"	"	"
			105	"	"	0.0 V	"	"	"	"	"	"	"	"	2.7 V	"	"	2.7 V	OUT	"	"	QD	"	"	"
			106	2.7 V	OUT	"	2.7 V	"	0.0 V	"	"	"	"	"	"	0.0 V	"	"	0.0 V	"	"	QA	"	"	"
			107	"	"	"	"	2.7 V	"	"	OUT	"	"	"	"	"	"	"	"	"	"	QB	"	"	"
			108	"	"	"	"	"	"	"	"	"	"	OUT	"	2.7 V	"	"	"	"	"	QC	"	"	"
			109	"	"	"	"	"	"	"	"	"	"	"	"	2.7 V	2.7 V	"	OUT	"	"	QD	"	"	"
			110	0.0 V	OUT	0.0 V	0.0 V	0.0 V	2.7 V	"	"	"	"	"	"	2.7 V	0.0 V	0.0 V	2.7 V	"	"	QA	"	9.5	"
	111	"	"	"	"	"	0.0 V	OUT	"	"	"	"	"	2.7 V	"	"	"	"	"	QB	"	"	"		
	112	"	"	"	"	"	"	"	"	"	"	OUT	0.0 V	"	"	"	"	"	"	QC	"	"	"		
	113	"	"	2.7 V	"	"	"	"	"	"	"	"	"	"	"	0.0 V	OUT	"	"	QD	"	"	"		
	114	2.7 V	OUT	0.0 V	"	2.7 V	"	"	"	"	"	"	"	"	2.7 V	2.7 V	"	"	"	QA	"	"	"		
	115	"	"	"	"	0.0 V	"	"	OUT	"	"	"	"	"	2.7 V	"	"	"	"	QB	"	"	"		
	116	"	"	"	"	"	"	"	"	"	"	"	OUT	"	0.0 V	"	"	"	"	QC	"	"	"		
	117	"	"	"	"	"	"	"	"	"	"	"	"	"	0.0 V	0.0 V	"	OUT	"	QD	"	"	"		
	118	0.0 V	OUT	IN2	0.0 V	0.0 V	0.0 V	"	"	IN1	"	"	"	0.0 V	0.0 V	0.0 V	0.0 V	"	"	QA	100	"	MHz		
	119	"	"	0.0 V	"	"	IN2	OUT	"	"	"	"	"	0.0 V	"	"	"	"	"	QB	"	"	"		
	120	"	"	"	"	"	0.0 V	"	"	"	"	"	OUT	IN2	"	"	"	"	"	QC	"	"	"		
	121	"	"	"	"	"	"	"	"	"	"	"	"	0.0 V	"	"	IN2	OUT	"	QD	"	"	"		
	122	2.7 V	OUT	"	IN2	"	"	"	"	"	"	"	"	"	"	"	0.0 V	"	"	QA	"	"	"		
	123	"	"	"	0.0 V	IN2	"	OUT	"	"	"	"	"	"	"	"	"	"	"	QB	"	"	"		
	124	"	"	"	"	0.0 V	"	"	"	"	"	"	OUT	"	IN2	"	"	"	"	QC	"	"	"		
	125	"	"	"	"	0.0 V	"	"	"	"	"	"	"	"	0.0 V	IN2	"	OUT	"	QD	"	"	"		
10	Same tests, terminal conditions, and limits as for subgroup 9, except T _c = +125°C and use limits from table I.																								
11	Same tests, terminal conditions and limits as for subgroup 9, except T _c = -55°C and use limits from table I.																								

- 1/ For case 2, pins not referenced are NC.
- 2/ Apply all voltages, then apply 3.0 V, 0.0 V, 3.0 V to CP then make measurement.
- 3/ Perform function sequence at V_{CC} = 4.5 V and repeat at V_{CC} = 5.5 V.
- 4/ A = 3.0 V, B = 0.0 V or GND; H > 1.5 V, L < 1.5 V.
- 5/ I_{IL} limits (mA) min/max values for circuit shown:

Test	Min/Max limits in mA		
	CKT A	B	C
I _{IL}	-0.25/-0.60	-0.03/-0.60	

- 6/ f_{MAX} shall be measured only under the conditions of initial qualification and after process or design changes which may affect this parameter. For all other conditions, f_{MAX} shall be guaranteed, if not tested, to the limits specified in table III, herein.

5. PACKAGING

5.1 Packaging requirements. For acquisition purposes, the packaging requirements shall be as specified in the contract or order (see 6.2). When actual packaging of materiel is to be performed by DoD or in-house contractor personnel, these personnel need to contact the responsible packaging activity to ascertain packaging requirements. Packaging requirements are maintained by the Inventory Control Point's packaging activity within the Military Service or Defense Agency, or within the military service's system command. Packaging data retrieval is available from the managing Military Department's or Defense Agency's automated packaging files, CD-ROM products, or by contacting the responsible packaging activity.

6. NOTES

6.1 Intended use. Microcircuits conforming to this specification are intended for original equipment design applications and logistic support of existing equipment.

6.2 Acquisition requirements. Acquisition documents should specify the following:

- a. Title, number, and date of the specification.
- b. PIN and compliance identifier, if applicable (see 1.2).
- c. Requirements for delivery of one copy of the conformance inspection data pertinent to the device inspection lot to be supplied with each shipment by the device manufacturer, if applicable.
- d. Requirements for certificate of compliance, if applicable.
- e. Requirements for notification of change of product or process to contracting activity in addition to notification to the qualifying activity, if applicable.
- f. Requirements for failure analysis (including required test condition of method 5003 of MIL-STD-883), corrective action, and reporting of results, if applicable.
- g. Requirements for product assurance options.
- h. Requirements for special carriers, lead lengths, or lead forming, if applicable. These requirements should not affect the part number. Unless otherwise specified, these requirements will not apply to direct purchase by or direct shipment to the Government.
- i. Requirements for "JAN" marking.
- j. Packaging requirements (see 5.1).

6.3 Superseding information. The requirements of MIL-M-38510 have been superseded to take advantage of the available Qualified Manufacturer Listing (QML) system provided by MIL-PRF-38535. Previous references to MIL-M-38510 in this document have been replaced by appropriate references to MIL-PRF-38535. All technical requirements now consist of this specification and MIL-PRF-38535. The MIL-M-38510 specification sheet number and PIN have been retained to avoid adversely impacting existing government logistics systems and contractor's parts lists.

6.4 Qualification. With respect to products requiring qualification, awards will be made only for products which are, at the time of award of contract, qualified for inclusion in Qualified Manufacturers List QML-38535 whether or not such products have actually been so listed by that date. The attention of the contractors is called to these requirements, and manufacturers are urged to arrange to have the products that they propose to offer to the Federal Government tested for qualification in order that they may be eligible to be awarded contracts or purchase orders for the products covered by this specification. Information pertaining to qualification of products may be obtained from DSCC-VQ, 3990 E. Broad Street, Columbus, Ohio 43123-1199.

6.5 Abbreviations, symbols, and definitions. The abbreviations, symbols, and definitions used herein are defined in MIL-PRF-38535, MIL-HDBK-1331, and as follows:

GND Ground zero voltage potential
 I_{IN} Current flowing into an input terminal
 V_{IN} Voltage level at an input terminal

6.6 Logistic support. Lead materials and finishes (see 3.4) are interchangeable. Unless otherwise specified, microcircuits acquired for Government logistic support will be acquired to device class B (see 1.2.2), lead material and finish A (see 3.4). Longer length leads and lead forming should not affect the part number.

6.7 Substitutability. The cross-reference information below is presented for the convenience of users. Microcircuits covered by this specification will functionally replace the listed generic-industry type. Generic-industry microcircuit types may not have equivalent operational performance characteristics across military temperature ranges or reliability factors equivalent to MIL-M-35810 device types and may have slight physical variations in relation to case size. The presence of this information should not be deemed as permitting substitution of generic-industry types for MIL-M-38510 types or as a waiver of any of the provisions of MIL-PRF-38535.

Military device type	Generic-industry type
01	54F398
02	54F399

6.8 Manufacturers' designation. Manufacturers' circuits which form a part of this specification are designated with an "X" as shown in table IV herein.

TABLE IV. Manufacturers' designations.

Device type	Manufacturer's designation		
	Circuit A	Circuit B	Circuit C
	National Semiconductor/ Fairchild Semiconductor	Motorola Inc.	Signetics Corp.
01	X		
02	X		

6.9 Changes from previous issue. Marginal notations are not used in this revision to identify changes with respect to the previous issue due to the extensiveness of the changes.

Custodians:
Army - CR
Navy - EC
Air Force - 11
DLA - CC

Preparing activity:
DLA - CC

(Project 5962-2041)

Review activities:
Army - MI, SM
Navy - AS, CG, MC, SH, TD
Air Force - 03, 19, 99

NOTE: The activities listed above were interested in this document as of the date of this document. Since organizations and responsibilities can change, you should verify the currency of the information above using the ASSIST Online database at www.dodssp.daps.mil.