

MILITARY SPECIFICATION

MICROCIRCUITS, DIGITAL, BIPOLAR, TTL, BUFFERS/DRIVERS OPEN COLLECTOR OUTPUT,
HIGH VOLTAGE, MONOLITHIC SILICON

Inactive for new design after 7 September 1995.

This specification is approved for use by all Departments and Agencies of the Department of Defense.

The requirements for acquiring the product herein shall consist of this specification sheet and MIL-PRF 38535

1. SCOPE

1.1 Scope. This specification covers the detail requirements for monolithic, silicon, TTL, buffers/drivers microcircuits with open collector high voltage outputs. Two product assurance classes and a choice of case outlines and lead finishes are provided for each type and are reflected in the complete part number. For this product, the requirements of MIL-M-38510 have been superseded by MIL-PRF-38535, (see 6.4).

1.2 Part or Identifying Number (PIN). The PIN is in accordance with MIL-PRF-38535, and as specified herein.

1.2.1 Device types. The device types are as follows:

<u>Device type</u>	<u>Circuit</u>
01	Hex inverter buffer/driver, 30-volt output
02	Hex inverter buffer/driver, 15-volt output
03	Hex buffer/driver, 30-volt output
04	Hex buffer/driver, 15-volt output
05	Quad 2 input inverter buffer/driver, 15-volt output

1.2.2 Device class. The device class is the product assurance level as defined in MIL-PRF-38535.

1.2.3 Case outlines. The case outlines are as designated in MIL-STD-1835 and as follows:

<u>Outline letter</u>	<u>Descriptive designator</u>	<u>Terminals</u>	<u>Package style</u>
A	GDFP5-F14 or CDFP6-F14	14	Flat pack
B	GDFP4-14	14	Flat pack
C	GDIP1-T14 or CDIP2-T14	14	Dual-in-line
D	GDFP1-F14 or CDFP2-F14	14	Flat pack

Comments, suggestions, or questions on this document should be addressed to: Commander, Defense Supply Center Columbus, ATTN: DSCC-VAS, P. O. Box 3990, Columbus, OH 43218-3990, or emailed to bipolar@dsc.dla.mil. Since contact information can change, you may want to verify the currency of this address information using the ASSIST Online database at <http://assist.daps.dla.mil>.

1.2.4 Absolute maximum ratings.

Supply voltage range	-0.5 V dc to +7.0 V dc
Input voltage range	-1.5 V dc at -12 mA to +5.5 V dc
Storage temperature range	-65°C to +150°C
Maximum power dissipation per gate, P_D ^{1/}	54 mW dc per buffer
Lead temperature (soldering 10 seconds)	300°C
Thermal resistance, junction-to-case (θ_{JC})	(See MIL-STD-1835)
Junction temperature (T_J) ^{2/}	175°C

1.2.5 Recommended operating conditions.

Supply voltage (V_{CC})	4.5 V dc minimum to 5.5 V dc maximum
Minimum high level input voltage (V_{IH})	2.0 V dc
Maximum low level input voltage (V_{IL})	0.8 V dc
Normalized fanout (each output) ^{3/} :	
Device types 01, 02, 03, and 04	18 maximum
Device type 05	10 maximum
Case operating temperature range (T_C)	-55°C to 125°C

2.0 APPLICABLE DOCUMENTS

2.1 General. The documents listed in this section are specified in sections 3, 4, or 5 of this specification. This section does not include documents cited in other sections of this specification or recommended for additional information or as examples. While every effort has been made to ensure the completeness of this list, document users are cautioned that they must meet all specified requirements of documents cited in sections 3, 4, or 5 of this specification, whether or not they are listed.

2.2 Government documents.

2.2.1 Specifications and standards. The following specifications and standards form a part of this specification to the extent specified herein. Unless otherwise specified, the issues of these documents are those cited in the solicitation or contract.

DEPARTMENT OF DEFENSE SPECIFICATIONS

MIL-PRF-38535 - Integrated Circuits (Microcircuits) Manufacturing, General Specification for.

DEPARTMENT OF DEFENSE STANDARDS

MIL-STD-883 - Test Method Standard for Microelectronics.
MIL-STD-1835 - Interface Standard Electronic Component Case Outlines

(Copies of these documents are available online at <http://assist.daps.dla.mil/quicksearch/> or <http://assist.daps.dla.mil> or from the Standardization Document Order Desk, 700 Robbins Avenue, Building 4D, Philadelphia, PA 19111-5094.)

2.3 Order of precedence. In the event of a conflict between the text of this specification and the references cited herein, the text of this document takes precedence. Nothing in this document, however, supersedes applicable laws and regulations unless a specific exemption has been obtained.

- ^{1/} Must withstand the added P_D due to short circuit condition (e.g. I_{OS}) at one output for 5 seconds duration.
^{2/} Maximum junction temperature should not be exceeded except in accordance with allowable short duration burn-in screening condition in accordance with MIL-PRF-38535.
^{3/} The device will fanout in both high and low levels to the specified number of inputs of the same device type as that being tested.

3. REQUIREMENTS

3.1 Qualification. Microcircuits furnished under this specification shall be products that are manufactured by a manufacturer authorized by the qualifying activity for listing on the applicable qualified manufacturers list before contract award (see 4.3 and 6.3).

3.2 Item requirements. The individual item requirements shall be in accordance with MIL-PRF-38535 and as specified herein or as modified in the device manufacturer's Quality Management (QM) plan. The modification in the QM plan shall not affect the form, fit, or function as described herein.

3.3 Design, construction, and physical dimensions. The design, construction, and physical dimensions shall be as specified in MIL-PRF-38535 and herein.

3.3.1 Logic diagram and terminal connections. The logic diagram and terminal connections shall be as specified on figure 1.

3.3.2 Truth tables and logic equations. The truth tables and logic equations shall be as specified on figure 2.

3.3.3 Schematic circuits. The schematic circuits shall be maintained by the manufacturer and made available to the qualifying activity and the preparing activity upon request.

3.3.4 Case outlines. Case outlines shall be as specified in 1.2.3.

3.4 Lead material and finish. Lead material and finish shall be in accordance with MIL-PRF-38535 (see 6.6).

3.5 Electrical performance characteristics. The electrical performance characteristics are as specified in table 1 and apply over the full recommended case operating temperature range, unless otherwise specified.

3.6 Electrical test requirements. The electrical test requirements for each device class shall be the subgroups specified in table II. The electrical tests for each subgroup are described in table III.

3.7 Marking. Marking shall be in accordance with MIL-PRF-38535.

3.8 Microcircuit group assignment. The devices covered by this specification shall be in microcircuit group number 2 (see MIL-PRF-38535, appendix A).

4. VERIFICATION

4.1 Sampling and inspection. Sampling and inspection procedures shall be in accordance with MIL-PRF-38535 or as modified in the device manufacturer's Quality Management (QM) plan. The modification in the QM plan shall not effect the form, fit, or function as described herein.

4.2 Qualification inspection. Qualification inspection shall be in accordance with MIL-PRF-38535.

4.2 Screening. Screening shall be in accordance with MIL-PRF-38535 and shall be conducted on all devices prior to qualification and conformance inspection. The following additional criteria shall apply:

- a. The burn-in test duration, test condition, and test temperature, or approved alternatives shall be as specified in the device manufacturer's QM plan in accordance with MIL-PRF-38535. The burn-in test circuit shall be maintained under document control by the device manufacturer's Technology Review Board (TRB) in accordance with MIL-PRF-38535 and shall be made available to the acquiring or preparing activity upon request. The test circuit shall specify the inputs, outputs, biases, and power dissipation, as applicable, in accordance with the intent specified in test method 1015 of MIL-STD-883.
- b. Interim and final electrical test parameters shall be as specified in table II, except interim electrical parameters test prior to burn-in is optional at the discretion of the manufacturer.
- c. Additional screening for space level product shall be as specified in MIL-PRF-38535.

TABLE I. Electrical performance characteristics.

Test	Symbol	Conditions -55°C ≤ T _C ≤ +125°C unless otherwise specified	Device type	Limits		
				Min	Max	Unit
High-level output voltage	V _{OH}	1/	01, 03	30		V
			02, 04, 05	15		
Input clamp voltage	V _{IC}	V _{CC} = 4.5 V, I _{IN} = -12 mA, T _A = 25° C	All		-1.5	V
Maximum collector cut-off current	I _{C_{EX}}	V _{CC} = 4.5 V, V _{OH} = MAX 4/	All		250	μA
Low-level output voltage	V _{OL1}	V _{CC} = 4.5 V, I _{OL} = 30 mA, 4/	01, 02 03, 04		0.7	V
Low-level output voltage	V _{OL2}	V _{CC} = 4.5 V, I _{OL} = 16 mA, 4/	All		0.4	V
High-level input current	I _{IH1}	V _{CC} = 5.5 V, V _{IN} = 2.4 V 2/	All		40	μA
High-level input current	I _{IH2}	V _{CC} = 5.5 V, V _{IN} = 5.5 V 2/	All		100	μA
Low-level input current	I _{IL1}	V _{CC} = 5.5 V, V _{IN} = 0.4 V 3/	01, 02 03, 04	-0.4	-1.6	mA
			05	-0.7	-1.6	
High-level supply current	I _{CCH}	V _{CC} = 5.5 V, V _{IN} = 0 V	01, 02		51	mA
		V _{CC} = 5.5 V, V _{IN} = 5.5 V	03, 04		46	mA
		V _{CC} = 5.5 V, V _{IN} = 0 V	05		8	mA
Low-level supply current	I _{CCL}	V _{CC} = 5.5 V, V _{IN} = 5.5 V	01, 02		48	mA
		V _{CC} = 5.5 V, V _{IN} = 0 V	03, 04		32	mA
		V _{CC} = 5.5 V, V _{IN} = 5.5 V	05		22	mA
Propagation delay time high-to-low level	t _{PHL}	C _L = 50 pF ±10% minimum, R _L = 150 Ω ±5%	01, 02	3	30	ns
			03, 04	3	35	ns
		C _L = 50 pF ±10% minimum, R _L = 1 kΩ ±5%	05	3	35	ns
Propagation delay time low-to-high level	t _{PLH}	C _L = 50 pF ±10% minimum, R _L = 150 Ω ±5%	01, 02	3	25	ns
			03, 04	3	20	ns
		C _L = 50 pF ±10% minimum, R _L = 1 kΩ ±5%	05	3	40	ns

*

1/ See I_{C_{EX}}.

2/ All unspecified inputs grounded.

3/ All unspecified input at 5.5 volts.

4/ V_{IL} = 0.7 V at 125°C only as follows:I_{C_{EX}}: device types 01, 02, 05.V_{OL1}, V_{OL2}: device types 03 and 04.

TABLE II. Electrical test requirements.

MIL-PRF-38535 Test requirement	Subgroups (see table III)	
	Class S Devices	Class B Devices
Interim electrical parameters	1	1
Final electrical test parameters	1*, 2, 3, 9, 10, 11	1*, 2, 3, 9
Group A test requirements	1, 2, 3, 9, 10, 11	1, 2, 3 9, 10, 11
Group B electrical test parameters when using the method 5005 QCI option	1, 2, 3, 9, 10, 11	N/A
Groups C end point electrical parameters	1, 2, 3 9, 10, 11	1, 2, 3
Group D end point electrical parameters	1, 2, 3	1, 2, 3

*PDA applies to subgroup 1.

4.3 Qualification inspection. Qualification inspection shall be in accordance with MIL-PRF-38535.

4.4 Technology Conformance Inspection (TCI). Technology conformance inspection shall be in accordance with MIL-PRF-38535 and herein for groups A, B, C, and D inspections (see 4.4.1 through 4.4.4).

4.4.1 Group A inspection. Group A inspection shall be in accordance with table III of MIL-PRF-38535 and as follows:

- a. Tests shall be as specified in table II herein.
- b. Subgroups 4, 5, 6, 7, and 8 shall be omitted.

4.4.2 Group B inspection. Group B inspection shall be in accordance with table II of MIL-PRF-38535.

4.4.3 Group C inspection. Group C inspection shall be in accordance with table IV of MIL-PRF-38535 and as follows:

- a. End point electrical parameters shall be as specified in table II herein.
- b. The steady-state life test duration, test condition, and test temperature, or approved alternatives shall be as specified in the device manufacturer's QM plan in accordance with MIL-PRF-38535. The burn-in test circuit shall be maintained under document control by the device manufacturer's Technology Review Board (TRB) in accordance with MIL-PRF-38535 and shall be made available to the acquiring or preparing activity upon request. The test circuit shall specify the inputs, outputs, biases, and power dissipation, as applicable, in accordance with the intent specified in test method 1005 of MIL-STD-883.

4.4.4 Group D inspection. Group D inspection shall be in accordance with table V of MIL-PRF-38535. End-point electrical parameters shall be as specified in table II herein.

4.5 Methods inspection. Methods of inspection shall be as specified in the appropriate tables and as follows:

4.5.1 Voltage and current. All voltages given are referenced to the microcircuit ground terminal. Currents given are conventional current and positive when flowing into the referenced terminal.

MIL-M-38510/8F

DEVICE TYPES 01 AND 02

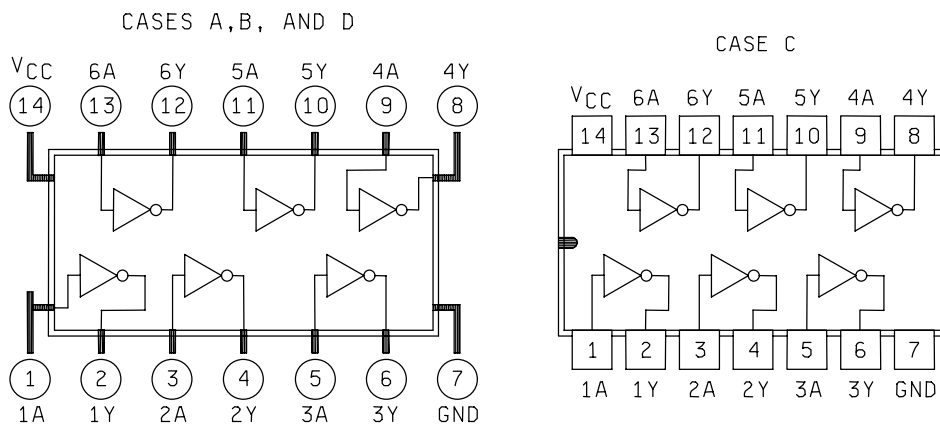

DEVICE TYPES 03 AND 04

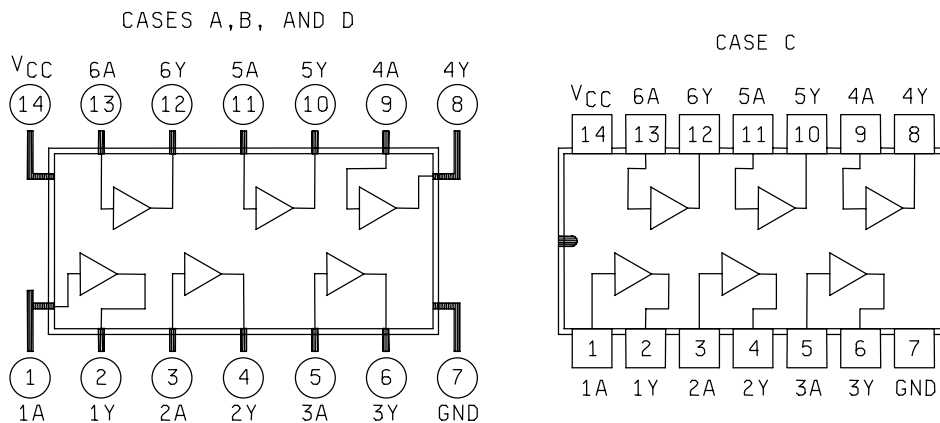

DEVICE TYPE 05

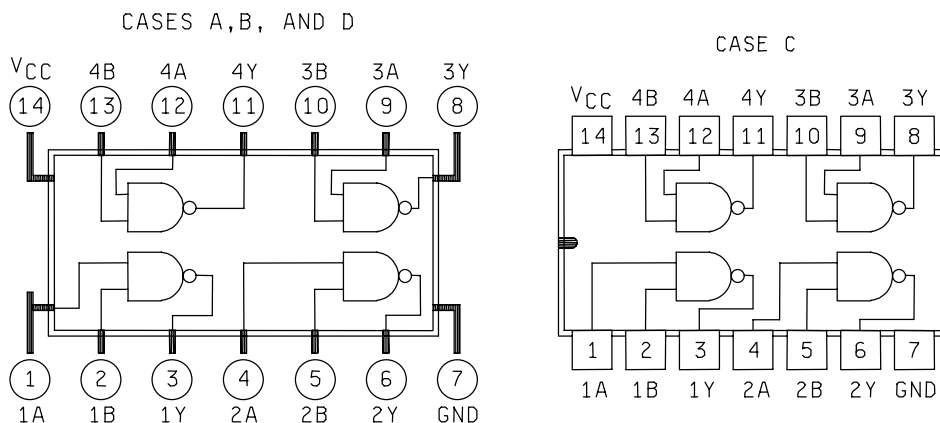

Figure 1. Logic diagram and terminal connections (top views).

Device types 01 and 02

Truth table each gate	
Input	Output
A	Y
L	H
H	L

Positive logic $Y = \bar{A}$

Device type 03 and 04

Truth table each gate	
Input	Output
A	Y
L	L
H	H

Positive logic $Y = A$

Device type 05

Truth table each gate		
Input		Output
A	B	Y
L	L	H
H	L	H
L	H	H
H	H	L

Positive logic $Y = \overline{AB}$

Figure 2. Truth tables and logic equations.

MIL-M-38510/8F

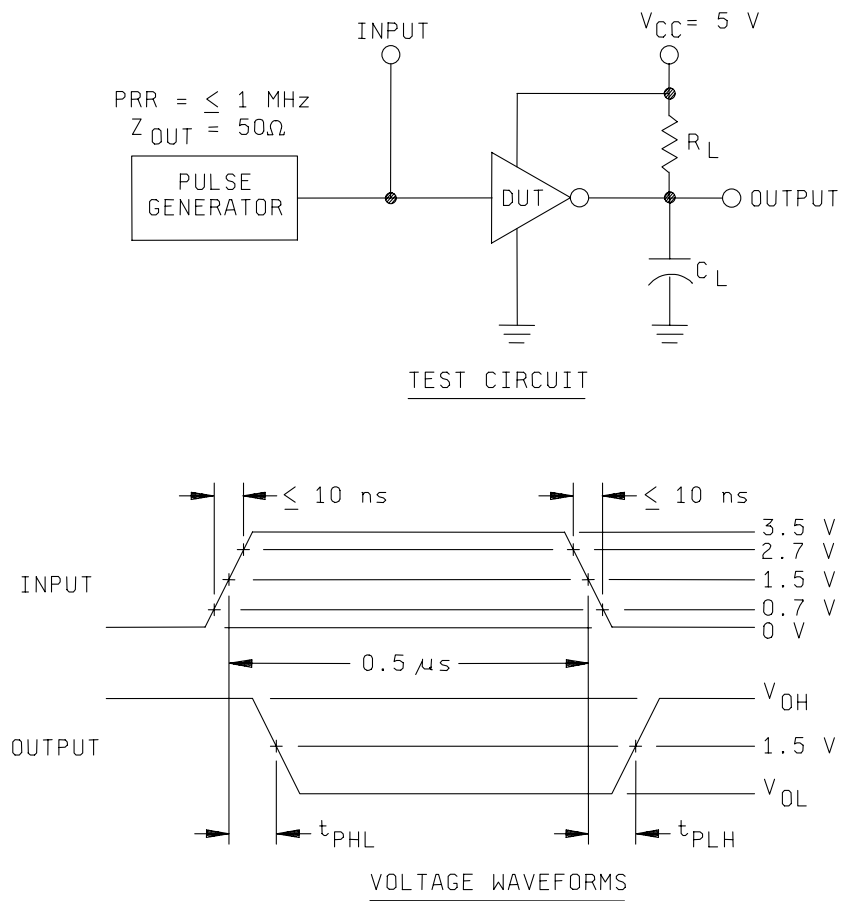

NOTES:

1. $C_L = 50\text{ pF} \pm 10\%$ minimum including scope probe, wiring, and stray capacitance, without package in test fixture.
2. Voltage measurements are to be made with respect to network ground terminal.
3. $R_L = 150\ \Omega \pm 5\%$.

FIGURE 3. Switching time test circuit for device types 01 and 02.

MIL-M-38510/8F

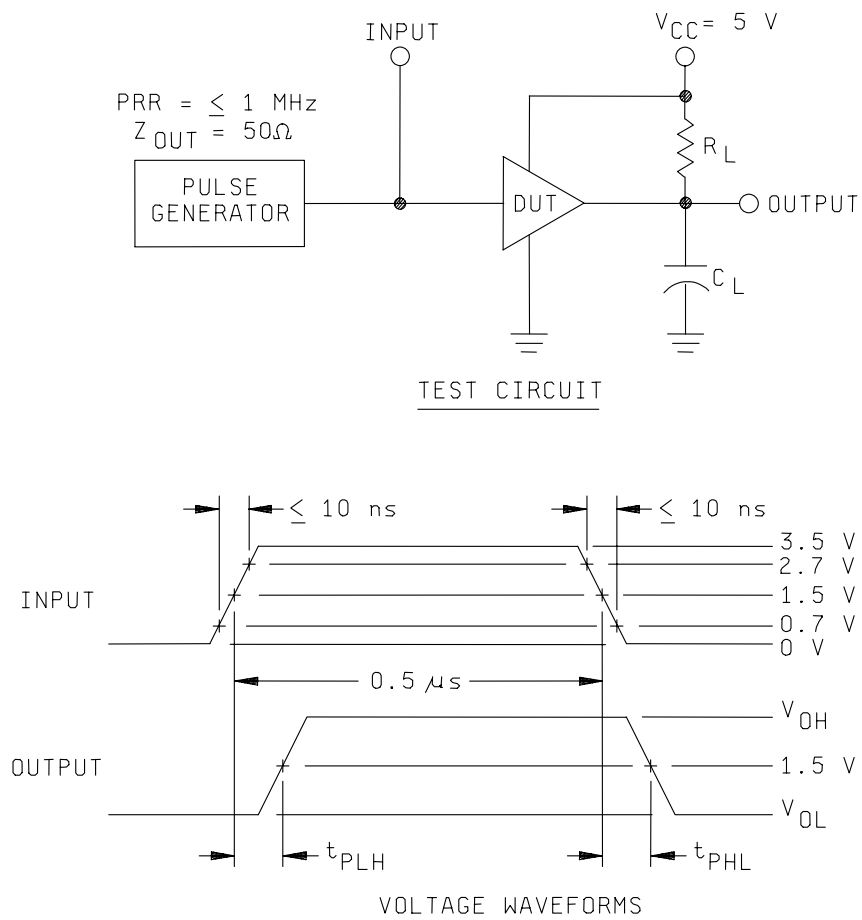

NOTES:

1. $C_L = 50\text{ pF} \pm 10\%$ minimum including scope probe, wiring, and stray capacitance, without package in test fixture.
2. Voltage measurements are to be made with respect to network ground terminal.
3. $R_L = 150\ \Omega \pm 5\%$.

FIGURE 4. Switching time test circuit for device types 03 and 04.

MIL-M-38510/8F

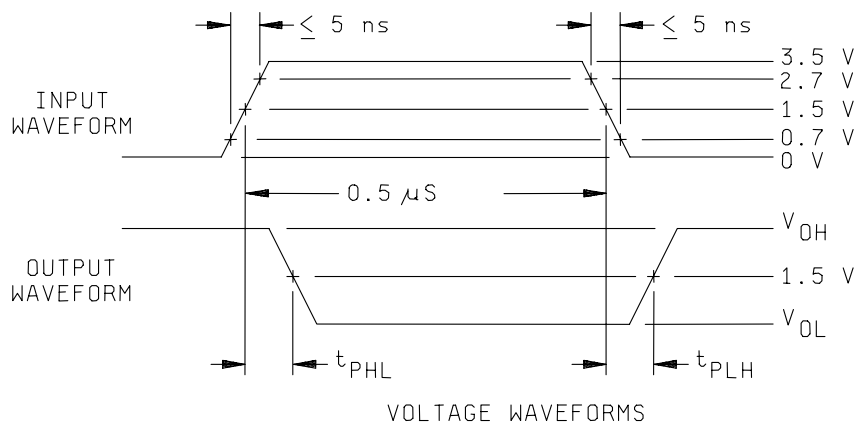
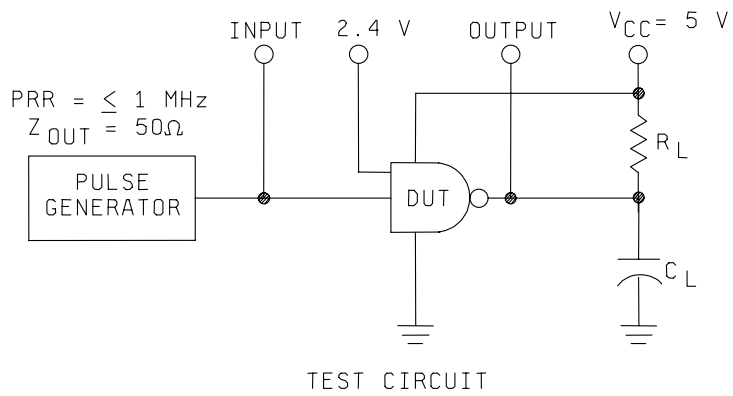

NOTES:

1. $C_L = 50\text{ pF} \pm 10\%$ minimum including scope probe, wiring, and stray capacitance, without package in test fixture.
2. Voltage measurements are to be made with respect to network ground terminal.
3. $R_L = 1\text{ k}\Omega \pm 5\%$.

FIGURE 5. Switching time test circuits for device type 05.

TABLE III. Group A inspection for device type 01 and 02.
Terminal conditions (High ≥ 2.0 V or Low ≤ 0.8 V or open).

Subgroup	Symbol	MIL-STD-883 method	Cases A,B,D	1	2	3	4	5	6	7	8	9	10	11	12	13	14	Meas. terminal	Test limits			
			Case C	1	2	3	4	5	6	7	8	9	10	11	12	13	14		Min	Max	Unit	
			Test No.	1A	1Y	2A	2Y	3A	3Y	GND	4Y	4A	5Y	5A	6Y	6A	V _{CC}					
1 T _C = +25°C	VOL1	3007	1	2.0 V	30 mA	5.5 V		5.5 V		GND		5.5 V		5.5 V		5.5 V	4.5 V	1Y		0.7	V	
	"	"	2	5.5 V		2.0 V	30 mA	5.5 V		"		"		"		"	"	2Y		"	"	
	"	"	3	"		5.5 V		5.5 V	30 mA	"		"		"		"	"	3Y		"	"	
	"	"	4	"		"		"		"	30 mA	2.0 V		"		"	"	4Y		"	"	
	"	"	5	"		"		"		"	"	5.5 V	30 mA	2.0 V		"	"	5Y		"	"	
	"	"	6	"		"		"		"	"	"		5.5 V	30 mA	2.0 V	"	6Y		"	"	
	"	VOL2	"	7	2.0 V	16 mA	"		"		"		"		"		5.5 V	"	1Y		0.4	"
	"	"	"	8	5.5 V		2.0 V	16 mA	"		"		"		"		"	"	2Y		"	"
	"	"	"	9	"		5.5 V		2.0 V	16 mA	"		"		"		"	"	3Y		"	"
	"	"	"	10	"		"		5.5 V		"	16 mA	2.0 V		"		"	"	4Y		"	"
	"	"	"	11	"		"		"		"	"	5.5 V	16 mA	2.0 V		"	"	5Y		"	"
	"	"	"	12	"		"		"		"	"	"		5.5 V	16 mA	2.0 V	"	6Y		"	"
	"	I _{CEX}		13	0.8 V	A	"		"		"		"		"		5.5 V	"	1Y		250	μA
	"	"		14	5.5 V		0.8 V	A	"		"		"		"		"	"	2Y		"	"
	"	"		15	"		5.5 V		0.8 V	A	"		"		"		"	"	3Y		"	"
	"	"		16	"		"		5.5 V		"	A	0.8 V		"		"	"	4Y		"	"
	"	"		17	"		"		"		"	"	5.5 V	A	0.8 V		"	"	5Y		"	"
	"	"		18	"		"		"		"	"	5.5 V		5.5 V	A	0.8 V	"	6Y		"	"
	"	V _{IC}		19	-12 mA						"						"	"	1A		-1.5	V
	"	"		20			-12 mA				"						"	"	2A		"	"
	"	"		21					-12 mA		"						"	"	3A		"	"
	"	"		22							"		-12 mA				"	"	4A		"	"
	"	"		23							"				-12 mA		"	"	5A		"	"
	"	"		24							"					-12 mA	"	"	6A		"	"
	"	I _{IH1}	3010	25	2.4 V		GND		GND		"		GND		GND		GND	5.5 V	1A		40	μA
	"	"	"	26	GND		2.4 V		GND		"		"		"		"	"	2A		"	"
	"	"	"	27	"		GND		2.4 V		"		"		"		"	"	3A		"	"
	"	"	"	28	"		"		GND		"		2.4 V		"		"	"	4A		"	"
	"	"	"	29	"		"		"		"		GND		2.4 V		"	"	5A		"	"
	"	"	"	30	"		"		"		"		"		GND		2.4 V	"	6A		"	"
	"	I _{IH2}	3010	31	5.5 V		"		"		"		"		"		GND	"	1A		100	"
	"	"	"	32	GND		5.5 V		"		"		"		"		"	"	2A		"	"
	"	"	"	33	"		GND		5.5 V		"		"		"		"	"	3A		"	"
	"	"	"	34	"		"		GND		"		5.5 V		"		"	"	4A		"	"
	"	"	"	35	"		"		"		"		GND		5.5 V		"	"	5A		"	"
	"	"	"	36	"		"		"		"		GND		GND		5.5 V	"	6A		"	"

Note: A = 30 volts for device type 01 and 15 volts for device type 02.

TABLE III. Group A inspection for device type 01 and 02. - Continued
Terminal conditions (High ≥ 2.0 V or Low ≤ 0.8 V or open).

Subgroup	Symbol	MIL-STD-883 method	Cases A,B,D	1	2	3	4	5	6	7	8	9	10	11	12	13	14	Meas. terminal	Test limits			
			Case C	1	2	3	4	5	6	7	8	9	10	11	12	13	14		Min	Max	Unit	
			Test No.	1A	1Y	2A	2Y	3A	3Y	GND	4Y	4A	5Y	5A	6Y	6A	V _{CC}					
1 T _C = +25°C	I _{IL}	3009	37 CKT A, C	0.4 V		5.5 V		5.5 V		GND		5.5 V		5.5 V		5.5 V	5.5 V	1A	-7	-1.6	mA	
	"	"	37 CKT B	0.4 V		5.5 V		"		"		"		"		"	"	1A	-4	-1.3	"	
	"	"	38 CKT A, C	5.5 V		0.4 V		"		"		"		"		"	"	2A	-7	-1.6	"	
	"	"	38 CKT B	"		0.4 V		"		"		"		"		"	"	2A	-4	-1.3	"	
	"	"	39 CKT A, C	"		5.5 V		0.4 V		"		"		"		"	"	3A	-7	-1.6	"	
	"	"	39 CKT B	"		"		0.4 V		"		"		"		"	"	3A	-4	-1.3	"	
	"	"	40 CKT A, C	"		"		5.5 V		"		0.4 V		"		"	"	4A	-7	-1.6	"	
	"	"	40 CKT B	"		"		"		"		0.4 V		"		"	"	4A	-4	-1.3	"	
	"	"	41 CKT A, C	"		"		"		"		5.5 V		0.4 V		"	"	5A	-7	-1.6	"	
	"	"	41 CKT B	"		"		"		"		"		0.4 V		"	"	5A	-4	-1.3	"	
	"	"	42 CKT A, C	"		"		"		"		"		5.5 V		0.4 V	"	6A	-7	-1.6	"	
	"	"	42 CKT B	"		"		"		"		"		"		0.4 V	"	6A	-4	-1.3	"	
	"	I _{CCL}	3005	43 CKT A	"		"		"		"		"		"	5.5 V	"	V _{CC}		41	"	"
	"	"	"	43 CKT B	"		"		"		"		"		"	"	"	"		48	"	"
"	"	"	43 CKT C	"		"		"		"		"		"	"	"	"		44	"	"	
"	I _{CCH}	"	44 CKT A	GND		GND		GND		"		GND		GND		GND	"	"		42	"	"
"	"	"	44 CKT B	"		"		"		"		"		"		"	"	"		51	"	"
"	"	"	44 CKT C	"		"		"		"		"		"		"	"	"		48	"	"
2	Same tests, terminal conditions and limits as for subgroup 1, except T _C = 125° C and V _{IC} tests are omitted. V _{IL} = 0.7 V for I _C EX.																					
3	Same tests, terminal conditions and limits as for subgroup 1, except T _C = -55° C and V _{IC} tests are omitted.																					
9 T _C = +25°C	t _{PHL}	3003 (Fig 3)	45	IN	OUT					GND							5.0 V	1A to 1Y	3	25	ns	
	"	"	46							"							"	2A to 2Y	"	"	"	
	"	"	47			IN	OUT			"							"	3A to 3Y	"	"	"	
	"	"	48					IN	OUT	"	OUT	IN					"	4A to 4Y	"	"	"	
	"	"	49							"			OUT	IN			"	5A to 5Y	"	"	"	
	"	"	50							"				OUT	IN		"	6A to 6Y	"	"	"	
	"	t _{PLH}	"	51	IN	OUT					"						"	1A to 1Y	"	20	"	
	"	"	"	52							"						"	2A to 2Y	"	"	"	
	"	"	"	53			IN	OUT			"						"	3A to 3Y	"	"	"	
	"	"	"	54					IN	OUT	"	OUT	IN				"	4A to 4Y	"	"	"	
	"	"	"	55							"			OUT	IN		"	5A to 5Y	"	"	"	
	"	"	"	56							"				OUT	IN	"	6A to 6Y	"	"	"	

TABLE III. Group A inspection for device type 01 and 02. - Continued
Terminal conditions (High ≥ 2.0 V or Low ≤ 0.8 V or open).

Subgroup	Symbol	MIL-STD-883 method	Cases A,B,D	1	2	3	4	5	6	7	8	9	10	11	12	13	14	Meas. terminal	Test limits		
			Case C	1	2	3	4	5	6	7	8	9	10	11	12	13	14		Min	Max	Unit
			Test No.	1A	1Y	2A	2Y	3A	3Y	GND	4Y	4A	5Y	5A	6Y	6A	V _{CC}				
10	t _{PHL}	3003	57	IN	OUT					GND							5.0 V	1A to 1Y	3	30	ns
T _C = +125°C	"	(Fig 3)	58			IN	OUT			"							"	2A to 2Y	"	"	"
"	"	"	59					IN	OUT	"							"	3A to 3Y	"	"	"
"	"	"	60							"	OUT	IN					"	4A to 4Y	"	"	"
"	"	"	61							"			OUT	IN			"	5A to 5Y	"	"	"
"	"	"	62							"				OUT	IN		"	6A to 6Y	"	"	"
"	t _{PLH}	"	63	IN	OUT					"							"	1A to 1Y	"	25	"
"	"	"	64			IN	OUT			"							"	2A to 2Y	"	"	"
"	"	"	65					IN	OUT	"							"	3A to 3Y	"	"	"
"	"	"	66							"	OUT	IN					"	4A to 4Y	"	"	"
"	"	"	67							"			OUT	IN			"	5A to 5Y	"	"	"
"	"	"	68							"				OUT	IN		"	6A to 6Y	"	"	"
11	Same tests, terminal conditions and limits as for subgroup 10, except T _C = -55°C.																				

TABLE III. Group A inspection for device type 03 and 04.
Terminal conditions (High \geq 2.0 V or Low \leq 0.8 V or open).

Subgroup	Symbol	MIL-STD-883 method	Cases A,B,D	1	2	3	4	5	6	7	8	9	10	11	12	13	14	Meas. terminal	Test limits		
			Case C	1	2	3	4	5	6	7	8	9	10	11	12	13	14		Min	Max	Unit
			Test No.	1A	1Y	2A	2Y	3A	3Y	GND	4Y	4A	5Y	5A	6Y	6A	V _{CC}				
1 T _C = +25°C	V _{OL1}	3007	1	0.8 V	30 mA	5.5 V		5.5 V		GND		5.5 V		5.5 V		5.5 V	4.5 V	1Y		0.7	V
	"	"	2	5.5 V		0.8 V	30 mA	5.5 V		"		"		"		"	"	2Y		"	"
	"	"	3	"		5.5 V		0.8 V	30 mA	"		"		"		"	"	3Y		"	"
	"	"	4	"		"		5.5 V		"	30 mA	0.8 V		"		"	"	4Y		"	"
	"	"	5	"		"		"		"		5.5 V	30 mA	0.8 V		"	"	5Y		"	"
	"	"	6	"		"		"		"		"		5.5 V	30 mA	0.8 V	"	6Y		"	"
"	V _{OL2}	"	7	0.8 V	16 mA	"		"		"		"		"		5.5 V	"	1Y		0.4	"
	"	"	8	5.5 V		0.8 V	16 mA	"		"		"		"		"	"	2Y		"	"
	"	"	9	"		5.5 V		0.8 V	16 mA	"		"		"		"	"	3Y		"	"
	"	"	10	"		"		5.5 V		"	16 mA	0.8 V		"		"	"	4Y		"	"
	"	"	11	"		"		"		"		5.5 V	16 mA	0.8 V		"	"	5Y		"	"
	"	"	12	"		"		"		"		"		5.5 V	16 mA	0.8 V	"	6Y		"	"
"	I _{CEX}	"	13	2.0 V	A	"		"		"		"		"		5.5 V	"	1Y		250	μA
	"	"	14	5.5 V		2.0 V	A	"		"		"		"		"	"	2Y		"	"
	"	"	15	"		5.5 V		2.0 V	A	"		"		"		"	"	3Y		"	"
	"	"	16	"		"		5.5 V		"	A	2.0 V		"		"	"	4Y		"	"
	"	"	17	"		"		"		"		5.5 V	A	2.0 V		"	"	5Y		"	"
	"	"	18	"		"		"		"		5.5 V		5.5 V	A	2.0 V	"	6Y		"	"
"	V _{IC}	"	19	-12 mA						"						"	"	1A		-1.5	V
	"	"	20			-12 mA				"						"	"	2A		"	"
	"	"	21					-12 mA		"						"	"	3A		"	"
	"	"	22							"		-12 mA				"	"	4A		"	"
	"	"	23							"				-12 mA		"	"	5A		"	"
	"	"	24							"					-12 mA	"	"	6A		"	"
"	I _{IH1}	3010	25	2.4 V		GND		GND		"		GND		GND		GND	5.5 V	1A		40	μA
	"	"	26	GND		2.4 V		GND		"		"		"		"	"	2A		"	"
	"	"	27	"		GND		2.4 V		"		"		"		"	"	3A		"	"
	"	"	28	"		"		GND		"		2.4 V		"		"	"	4A		"	"
	"	"	29	"		"		"		"		GND		2.4 V		"	"	5A		"	"
	"	"	30	"		"		"		"		"		GND		2.4 V	"	6A		"	"
"	I _{IH2}	3010	31	5.5 V		"		"		"		"		"		GND	"	1A		100	"
	"	"	32	GND		5.5 V		"		"		"		"		"	"	2A		"	"
	"	"	33	"		GND		5.5 V		"		"		"		"	"	3A		"	"
	"	"	34	"		"		GND		"		5.5 V		"		"	"	4A		"	"
	"	"	35	"		"		"		"		GND		5.5 V		"	"	5A		"	"
	"	"	36	"		"		"		"		GND		GND		5.5 V	"	6A		"	"

Note: A = 30 volts for device type 03 and 15 for device type 04.

TABLE III. Group A inspection for device type 03 and 04. - Continued
Terminal conditions (High ≥ 2.0 V or Low ≤ 0.8 V or open).

Subgroup	Symbol	MIL-STD-883 method	Cases A,B,D	1	2	3	4	5	6	7	8	9	10	11	12	13	14	Meas. terminal	Test limits			
			Case C	1	2	3	4	5	6	7	8	9	10	11	12	13	14		Min	Max	Unit	
			Test No.	1A	1Y	2A	2Y	3A	3Y	GND	4Y	4A	5Y	5A	6Y	6A	V _{CC}					
1 T _C = +25°C	I _L	3009	37 CKT A, C	0.4 V		5.5 V		5.5 V		GND		5.5 V		5.5 V		5.5 V	5.5 V	1A	-7	-1.6	mA	
	"	"	37 CKT B	0.4 V		5.5 V		"		"		"		"		"	"	1A	-4	-1.3	"	
	"	"	38 CKT A, C	5.5 V		0.4 V		"		"		"		"		"	"	2A	-7	-1.6	"	
	"	"	38 CKT B	"		0.4 V		"		"		"		"		"	"	2A	-4	-1.3	"	
	"	"	39 CKT A, C	"		5.5 V		0.4 V		"		"		"		"	"	3A	-7	-1.6	"	
	"	"	39 CKT B	"		"		0.4 V		"		"		"		"	"	3A	-4	-1.3	"	
	"	"	40 CKT A, C	"		"		5.5 V		"		0.4 V		"		"	"	4A	-7	-1.6	"	
	"	"	40 CKT B	"		"		"		"		0.4 V		"		"	"	4A	-4	-1.3	"	
	"	"	41 CKT A, C	"		"		"		"		5.5 V		0.4 V		"	"	5A	-7	-1.6	"	
	"	"	41 CKT B	"		"		"		"		"		0.4 V		"	"	5A	-4	-1.3	"	
	"	"	42 CKT A, C	"		"		"		"		"		5.5 V		0.4 V	"	6A	-7	-1.6	"	
	"	"	42 CKT B	"		"		"		"		"		"		0.4 V	"	6A	-4	-1.3	"	
	"	I _{CCL}	3005	43 CKT A, B	"		"		"		"		"			5.5 V	"	V _{CC}		42	"	"
	"	I _{CCL}	"	43 CKT C	"		"		"		"		"			5.5 V	"	"		46	"	"
"	I _{CCCH}	"	44 CKT A, B	GND		GND		GND		"		GND		GND		GND	"	"		30	"	"
"	I _{CCCH}	"	44 CKT C	GND		GND		GND		"		GND		GND		GND	"	"		32	"	"
2	Same tests, terminal conditions and limits as for subgroup 1, except T _C = 125° C and V _{IC} tests are omitted. V _{IL} = 0.7 V for VOL1 and VOL2.																					
3	Same tests, terminal conditions and limits as for subgroup 1, except T _C = -55° C and V _{IC} tests are omitted.																					
9 T _C = +25°C	t _{PHL}	3003	45	IN	OUT					GND							5.0 V	1A to 1Y	3	26	ns	
	"	(Fig 4)	46			IN	OUT			"							"	2A to 2Y	"	"	"	
	"	"	47					IN	OUT	"							"	3A to 3Y	"	"	"	
	"	"	48							"	OUT	IN					"	4A to 4Y	"	"	"	
	"	"	49							"			OUT	IN			"	5A to 5Y	"	"	"	
	"	"	50							"				OUT	IN		"	6A to 6Y	"	"	"	
	"	t _{PLH}	"	51	IN	OUT					"						"	1A to 1Y	"	15	"	
	"	"	"	52			IN	OUT			"						"	2A to 2Y	"	"	"	
	"	"	"	53					IN	OUT	"						"	3A to 3Y	"	"	"	
	"	"	"	54							"	OUT	IN				"	4A to 4Y	"	"	"	
"	"	"	55							"			OUT	IN		"	5A to 5Y	"	"	"		
"	"	"	56							"				OUT	IN	"	6A to 6Y	"	"	"		

TABLE III. Group A inspection for device type 03 and 04. - Continued
Terminal conditions (High ≥ 2.0 V or Low ≤ 0.8 V or open).

Subgroup	Symbol	MIL-STD-883 method	Cases A,B,D	1	2	3	4	5	6	7	8	9	10	11	12	13	14	Meas. terminal	Test limits		
			Case C	1	2	3	4	5	6	7	8	9	10	11	12	13	14		Min	Max	Unit
			Test No.	1A	1Y	2A	2Y	3A	3Y	GND	4Y	4A	5Y	5A	6Y	6A	V _{CC}				
10	t _{PHL}	3003	57	IN	OUT					GND							5.0 V	1A to 1Y	3	35	ns
T _C = +125°C	"	(Fig 4)	58			IN	OUT			"							"	2A to 2Y	"	"	"
"	"	"	59					IN	OUT	"							"	3A to 3Y	"	"	"
"	"	"	60							"	OUT	IN					"	4A to 4Y	"	"	"
"	"	"	61							"			OUT	IN			"	5A to 5Y	"	"	"
"	"	"	62							"				OUT	IN		"	6A to 6Y	"	"	"
"	t _{PLH}	"	63	IN	OUT					"							"	1A to 1Y	"	20	"
"	"	"	64			IN	OUT			"							"	2A to 2Y	"	"	"
"	"	"	65					IN	OUT	"							"	3A to 3Y	"	"	"
"	"	"	66							"	OUT	IN					"	4A to 4Y	"	"	"
"	"	"	67							"			OUT	IN			"	5A to 5Y	"	"	"
"	"	"	68							"				OUT	IN		"	6A to 6Y	"	"	"
11	Same tests, terminal conditions and limits as for subgroup 10, except T _C = -55°C.																				

*

TABLE III. Group A inspection for device type 05.
Terminal conditions (High ≥ 2.0 V or Low ≤ 0.8 V or open).

Subgroup	Symbol	MIL-STD-883 method	Cases A,B,D	1	2	3	4	5	6	7	8	9	10	11	12	13	14	Meas. terminal	Test limits		
			Case C	1	2	3	4	5	6	7	8	9	10	11	12	13	14		Min	Max	Unit
			Test No.	1A	1B	1Y	2A	2B	2Y	GND	3Y	3A	3B	4Y	4A	4B	V _{CC}				
1	V _{OL2}	3007	1	2.0 V	2.0 V	16 mA	5.5 V	5.5 V		GND		5.5 V	5.5 V		5.5 V	5.5 V	4.5 V	1Y		0.4	V
"	"	"	2	5.5 V	5.5 V		2.0 V	2.0 V	16 mA	"		5.5 V	5.5 V		"	"	"	2Y		"	"
"	"	"	3	"	"		5.5 V	5.5 V		"	16 mA	2.0 V	2.0 V		"	"	"	3Y		"	"
"	"	"	4	"	"		"	"		"		5.5 V	5.5 V	16 mA	2.0 V	2.0 V	"	4Y		"	"
"	I _{CEX}		5	0.8 V	2.0 V	15.0 V	"	"		"		"	"		5.5 V	5.5 V	"	1Y		250	μ A
"	"		6	2.0 V	0.8 V	15.0 V	"	"		"		"	"		"	"	"	1Y		"	"
"	"		7	5.5 V	5.5 V		0.8 V	2.0 V	15.0 V	"		"	"		"	"	"	2Y		"	"
"	"		8	"	"		2.0 V	0.8 V	15.0 V	"		"	"		"	"	"	2Y		"	"
"	"		9	"	"		5.5 V	5.5 V		"	15.0 V	0.8 V	2.0 V		"	"	"	3Y		"	"
"	"		10	"	"		"	"		"	15.0 V	2.0 V	0.8 V		"	"	"	3Y		"	"
"	"		11	"	"		"	"		"		5.5 V	5.5 V	15.0 V	0.8 V	2.0 V	"	4Y		"	"
"	"		12	"	"		"	"		"		5.5 V	5.5 V	15.0 V	2.0 V	0.8 V	"	4Y		"	"
"	V _{IC}		13	-12 mA						"							"	1A		-1.5	V
"	"		14		-12 mA					"							"	1B		"	"
"	"		15				-12 mA			"							"	2A		"	"
"	"		16					-12 mA		"							"	2B		"	"
"	"		17							"		-12 mA					"	3A		"	"
"	"		18							"			-12 mA				"	3B		"	"
"	"		19							"				-12 mA			"	4A		"	"
"	"		20							"					-12 mA		"	4B		"	"
"	I _{IH1}	3010	21	2.4 V	GND		GND	GND		"		GND	GND		GND	GND	5.5 V	1A		40	μ A
"	"	"	22	GND	2.4 V		GND	"		"		"	"		"	"	"	1B		"	"
"	"	"	23	"	GND		2.4 V	"		"		"	"		"	"	"	2A		"	"
"	"	"	24	"	"		GND	2.4 V		"		"	"		"	"	"	2B		"	"
"	"	"	25	"	"		"	GND		"		2.4 V	"		"	"	"	3A		"	"
"	"	"	26	"	"		"	"		"		GND	2.4 V		"	"	"	3B		"	"
"	"	"	27	"	"		"	"		"		"	GND		2.4 V	"	"	4A		"	"
"	"	"	28	"	"		"	"		"		"	"		GND	2.4 V	"	4B		"	"
"	I _{IH2}	3010	29	5.5 V	"		"	"		"		"	"		"	GND	"	1A		100	"
"	"	"	30	GND	5.5 V		"	"		"		"	"		"	"	"	1B		"	"
"	"	"	31	"	GND		5.5 V	"		"		"	"		"	"	"	2A		"	"
"	"	"	32	"	"		GND	5.5 V		"		"	"		"	"	"	2B		"	"
"	"	"	33	"	"		"	GND		"		5.5 V	"		"	"	"	3A		"	"
"	"	"	34	"	"		"	"		"		GND	5.5 V		"	"	"	3B		"	"
"	"	"	35	"	"		"	"		"		"	GND		5.5 V	"	"	4A		"	"
"	"	"	36	"	"		"	"		"		"	GND		GND	5.5 V	"	4B		"	"

TABLE III. Group A inspection for device type 05. - Continued
Terminal conditions (High ≥ 2.0 V or Low ≤ 0.8 V or open).

Subgroup	Symbol	MIL-STD-883 method	Cases A,B,D	1	2	3	4	5	6	7	8	9	10	11	12	13	14	Meas. terminal	Test limits		
			Case C	1	2	3	4	5	6	7	8	9	10	11	12	13	14		Min	Max	Unit
			Test No.	1A	1B	1Y	2A	2B	2Y	GND	3Y	3A	3B	4Y	4A	4B	V _{CC}				
1 T _C = +25°C	I _{IL}	3009	37	0.4 V	5.5 V		5.5 V	5.5 V		GND		5.5 V	5.5 V		5.5 V	5.5 V	5.5 V	1A	-7	-1.6	mA
	"	"	38	5.5 V	0.4 V		5.5 V	"		"		"	"		"	"	"	1B	"	"	"
	"	"	39	"	5.5 V		0.4 V	"		"		"	"		"	"	"	2A	"	"	"
	"	"	40	"	"		5.5 V	0.4 V		"		"	"		"	"	"	2B	"	"	"
	"	"	41	"	"		"	5.5 V		"		0.4 V	"		"	"	"	3A	"	"	"
	"	"	42	"	"		"	"		"		5.5 V	0.4 V		"	"	"	3B	"	"	"
	"	"	43	"	"		"	"		"		"	5.5 V		0.4 V	"	"	4A	"	"	"
	"	"	44	"	"		"	"		"		"	"		5.5 V	0.4 V	"	4B	"	"	"
	"	I _{CCL}	3005	45	"	"		"	"		"		"	"	5.5 V	5.5 V	"	V _{CC}		22	"
	"	I _{CCH}	3005	46	GND	GND		GND	GND		"		GND	GND		GND	GND	"	V _{CC}		8
2	Same tests, terminal conditions and limits as for subgroup 1, except T _C = 125° C and V _{IC} tests are omitted. V _{IL} = 0.7 V for I _{CEX} .																				
3	Same tests, terminal conditions and limits as for subgroup 1, except T _C = -55° C and V _{IC} tests are omitted.																				
9 T _C = +25°C	t _{PHL}	3003	47	IN	2.4 V	OUT				GND							5.0 V	1A to 1Y	3	25	ns
	"	(Fig 5)	48				IN	2.4 V	OUT	"	OUT	IN	2.4 V				"	2A to 2Y	"	"	"
	"	"	49							"				OUT	IN	2.4 V	"	3A to 3Y	"	"	"
	"	"	50							"							"	4A to 4Y	"	"	"
	t _{PLH}	"	51	IN	2.4 V	OUT				"							"	1A to 1Y	"	30	"
	"	"	52				IN	2.4 V	OUT	"							"	2A to 2Y	"	"	"
	"	"	53							"	OUT	IN	2.4 V				"	3A to 3Y	"	"	"
	"	"	54							"				OUT	IN	2.4 V	"	4A to 4Y	"	"	"
10 T _C = +125°C	t _{PHL}	"	55	IN	2.4 V	OUT				"							"	1A to 1Y	"	35	"
	"	"	56				IN	2.4 V	OUT	"							"	2A to 2Y	"	"	"
	"	"	57							"	OUT	IN	2.4 V				"	3A to 3Y	"	"	"
	"	"	58							"				OUT	IN	2.4 V	"	4A to 4Y	"	"	"
	t _{PLH}	"	59	IN	2.4 V	OUT				"							"	1A to 1Y	"	40	"
	"	"	60				IN	2.4 V	OUT	"							"	2A to 2Y	"	"	"
"	"	61							"	OUT	IN	2.4 V				"	3A to 3Y	"	"	"	
"	"	62							"				OUT	IN	2.4 V	"	4A to 4Y	"	"	"	
11	Same tests, terminal conditions and limits as for subgroup 10, except T _C = -55°C.																				

5. PACKAGING

5.1 Packaging requirements. For acquisition purposes, the packaging requirements shall be as specified in the contract or order (see 6.2). When packaging of materiel is to be performed by DoD or in-house contractor personnel, these personnel need to contact the responsible packaging activity to ascertain packaging requirements. Packaging requirements are maintained by the Inventory Control Point's packaging activity within the Military Service or Defense Agency, or within the military service's system command. Packaging data retrieval is available from the managing Military Department's or Defense Agency's automated packaging files, CD-ROM products, or by contacting the responsible packaging activity. *

6. NOTES

(This section contains information of a general or explanatory nature that may be helpful, but is not mandatory)

6.1 Intended use. Microcircuits conforming to this specification are intended for logistic support of existing equipment. *

6.2 Acquisition requirements. Acquisition documents should specify the following:

- a. Title, number, and date of the specification.
- b. PIN and compliance identifier, if applicable (see 1.2).
- c. Requirements for delivery of one copy of the conformance inspection data pertinent to the device inspection lot to be supplied with each shipment by the device manufacturer, if applicable.
- d. Requirement for certificate of compliance, if applicable.
- e. Requirements for notification of change of product or process to acquiring activity in addition to notification to the qualifying activity, if applicable.
- f. Requirements for failure analysis (including required test condition of method 5003), corrective action and reporting of results, if applicable.
- g. Requirements for product assurance options.
- h. Requirements for carriers, special lead lengths or lead forming, if applicable. These requirements shall not affect the part number. Unless otherwise specified, these requirements will not apply to direct purchase by or direct shipment to the Government.
- i. Requirements for "JAN" marking.
- j. Packaging requirements (see 5.1).

6.3 Qualification. With respect to products requiring qualification, awards will be made only for products which are, at the time of award of contract, qualified for inclusion in Qualified Manufacturers List QML-38535 whether or not such products have actually been so listed by that date. The attention of the contractors is called to these requirements, and manufacturers are urged to arrange to have the products that they propose to offer to the Federal Government tested for qualification in order that they may be eligible to be awarded contracts or purchase orders for the products covered by this specification. Information pertaining to qualification of products may be obtained from DSCC-VQ, 3990 E. Broad Street, Columbus, Ohio 43123-1199.

6.4 Superseding information. The requirements of MIL-M-38510 have been superseded to take advantage of the available Qualified Manufacturer Listing (QML) system provided by MIL-PRF-38535. Previous references to MIL-M-38510 in this document have been replaced by appropriate references to MIL-PRF-38535. All technical requirements now consist of this specification and MIL-PRF-38535. The MIL-M-38510 specification sheet number and PIN have been retained to avoid adversely impacting existing government logistics systems and contractor's parts lists.

6.5 Abbreviations, symbols and definitions. The abbreviations, symbols, and definitions used herein are defined in MIL-PRF-38535 and MIL-HDBK-1331, and as follows:

- GND Ground zero voltage potential.
- V_{IN} Voltage level at an input terminal.
- V_{IC} Input clamp voltage.
- I_{IN} Current-flowing into an input terminal.

6.6 Logistic support. Lead materials and finishes (see 3.3) are interchangeable. Unless otherwise specified, microcircuits acquired for Government logistic support will be acquired to device class B (see 1.2.2), lead material and finish A (see 3.4). Longer lead lengths and lead forming should not affect the part number.

6.7 Substitutability. The cross-reference information below is presented for the convenience of users. Microcircuits covered by this specification will functionally replace the listed generic-industry type. Generic-industry microcircuit types may not have equivalent operational performance characteristics across military temperature ranges or reliability factors equivalent to MIL-M-35810 device types and may have slight physical variations in relation to case size. The presence of this information should not be deemed as permitting substitution of generic-industry types for MIL-M-38510 types or as a waiver of any of the provisions of MIL-PRF-38535.

<u>Device type</u>	<u>Commercial type</u>
01	5406
02	5416
03	5407
04	5417
05	5426

6.8 Supersession information. MIL-M-38510/8F supersedes MIL-M-38510/8E. MIL-M-0038510/8C(19) was issued as an "in lieu of" document for MIL-M-38510/8B and was superseded by MIL-M-38510/8D.

6.9 Changes from previous issue. The margins of this specification are marked with asterisks to indicate where changes from the previous issue were made. This was done as a convenience only and the Government assumes no liability whatsoever for any inaccuracies in these notations. Bidders and contractors are cautioned to evaluate the requirements of this document based on the entire content irrespective of the marginal notations and relationship to the last previous issue.

Custodians:
 Army - CR
 Navy - EC
 Air Force - 11
 DLA - CC

Preparing activity:
 DLA - CC

 (Project 5962-2005-005)

Review activities:
 Army - MI, SM
 Navy - AS, CG, MC, SH, TD
 Air Force - 03, 19, 99

NOTE: The activities listed above were interested in this document as of the date of this document. Since organizations and responsibilities can change, you should verify the currency of the information above using the ASSIST Online database at <http://assist.daps.dla.mil>.