

REVISIONS

LTR	DESCRIPTION	DATE (YR-MO-DA)	APPROVED
A	Complete revision; conversion to Approved Source format.	82-12-09	N. A. HAUCK
B	Page 2, paragraph 1.3 and 1.4, change low limit for ambient operating temperature range. Page 4, table I, change reverse breakdown voltage, reverse dynamic impedance, reverse leakage current, forward voltage drop, and breakdown voltage temperature coefficient. Engineering and editorial changes throughout.	84-11-13	N. A. HAUCK
C	Change to military drawing format. Table I, change V_{RB} specification. Editorial changes throughout.	87-05-04	N. A. HAUCK
D	Change in absolute maximum rating for operating temperature range. Delete 4.3.1c. Change code ident. no. to 67268. Remove subgroups 5 and 6 from table II.	87-09-17	N. A. HAUCK
E	Add vendor CAGE 34333 to device types 01, 05, and 11. Add vendor CAGE 15818 to device type 01. Delete vendor 27014 for device types 01, 02, 03, 04, 05, 10, 11, 12, and 13. Editorial changes throughout. Device types 02, 03, 04, and 10 inactive for new design.	88-09-26	M. A. FRYE
F	Drawing updated to reflect current requirements. Replaced reference to MIL-STD-973 with reference to MIL-PRF-38535. - rrp	03-12-16	R. MONNIN
G	Correction to marking paragraph 3.5. Editorial changes throughout. - drw	05-02-16	R. MONNIN
H	Update boilerplate paragraphs to current MIL-PRF-38535 requirements. - ro	11-06-07	C. SAFFLE

CURRENT CAGE CODE 67268

THE ORIGINAL FIRST SHEET OF THIS DRAWING HAS BEEN REPLACED.

REV																				
SHEET																				
REV																				
SHEET																				
REV STATUS	REV	H	H	H	H	H	H	H	H	H	H									
OF SHEETS	SHEET	1	2	3	4	5	6	7	8	9										
PMIC N/A	PREPARED BY WILLIAM E. SHOUP	<p align="center">DLA LAND AND MARITIME COLUMBUS, OHIO 43218-3990 http://www.dsc.dla.mil</p> <p align="center">MICROCIRCUIT, LINEAR, VOLTAGE REFERENCE, MONOLITHIC SILICON</p>																		
<p align="center">STANDARD MICROCIRCUIT DRAWING</p> <p align="center">THIS DRAWING IS AVAILABLE FOR USE BY ALL DEPARTMENTS AND AGENCIES OF THE DEPARTMENT OF DEFENSE</p>	CHECKED BY C. R. JACKSON																			
	APPROVED BY N. A. HAUCK																			
	DRAWING APPROVAL DATE 77-09-16																			
AMSC N/A	REVISION LEVEL H	SIZE A	CAGE CODE 14933	77028																
			SHEET 1 OF 9																	

1. SCOPE

1.1 Scope. This drawing describes device requirements for MIL-STD-883 compliant, non-JAN class level B microcircuits in accordance with MIL-PRF-38535, appendix A.

1.2 Part or Identifying Number (PIN). The complete PIN is as shown in the following example:

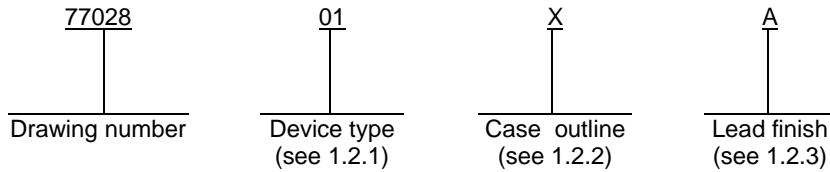

1.2.1 Device type(s). The device type(s) identify the circuit function as follows:

Device type	Generic number	Circuit function	V_B at $I_R = 1 \text{ mA}$
01	LM103H-1.8	Voltage reference	1.8 V
02	LM103H-2.0	Voltage reference	2.0 V
03	LM103H-2.2	Voltage reference	2.2 V
04	LM103H-2.4	Voltage reference	2.4 V
05	LM103H-2.7	Voltage reference	2.7 V
06	LM103H-3.0	Voltage reference	3.0 V
07	LM103H-3.3	Voltage reference	3.3 V
08	LM103H-3.6	Voltage reference	3.6 V
09	LM103H-3.9	Voltage reference	3.9 V
10	LM103H-4.3	Voltage reference	4.3 V
11	LM103H-4.7	Voltage reference	4.7 V
12	LM103H-5.1	Voltage reference	5.1 V
13	LM103H-5.6	Voltage reference	5.6 V

1.2.2 Case outline(s). The case outline(s) are as designated in MIL-STD-1835 and as follows:

<u>Outline letter</u>	<u>Descriptive designator</u>	<u>Terminals</u>	<u>Package style</u>
X	See figure 1	2	Modified can (TO-46)

1.2.3 Lead finish. The lead finish is as specified in MIL-PRF-38535, appendix A.

1.3 Absolute maximum ratings.

Power dissipation (P_D) ^{1/}	250 mW
Reverse current (I_R)	20 mA
Forward current (I_F)	100 mA
Storage temperature range	-65°C to +150°C
Lead temperature (60 seconds)	+300°C
Junction temperature (T_J)	+150°C/W

^{1/} Operation at elevated temperature requires device derating based on +150°C maximum junction temperature, thermal resistance of 80°C/W junction to case or +440°C/W junction to ambient.

STANDARD MICROCIRCUIT DRAWING DLA LAND AND MARITIME COLUMBUS, OHIO 43218-3990	SIZE A		77028
		REVISION LEVEL H	SHEET 2

1.4 Recommended operating conditions.

Ambient operating temperature range (T_A) -55°C to +125°C

2. APPLICABLE DOCUMENTS

2.1 Government specification, standards, and handbooks. The following specification, standards, and handbooks form a part of this drawing to the extent specified herein. Unless otherwise specified, the issues of these documents are those cited in the solicitation or contract.

DEPARTMENT OF DEFENSE SPECIFICATION

MIL-PRF-38535 - Integrated Circuits, Manufacturing, General Specification for.

DEPARTMENT OF DEFENSE STANDARDS

MIL-STD-883 - Test Method Standard Microcircuits.
MIL-STD-1835 - Interface Standard Electronic Component Case Outlines.

DEPARTMENT OF DEFENSE HANDBOOKS

MIL-HDBK-103 - List of Standard Microcircuit Drawings.
MIL-HDBK-780 - Standard Microcircuit Drawings.

(Copies of these documents are available online at <https://assist.daps.dla.mil/quicksearch/> or from the Standardization Document Order Desk, 700 Robbins Avenue, Building 4D, Philadelphia, PA 19111-5094.)

2.2 Order of precedence. In the event of a conflict between the text of this drawing and the references cited herein, the text of this drawing takes precedence. Nothing in this document, however, supersedes applicable laws and regulations unless a specific exemption has been obtained.

3. REQUIREMENTS

3.1 Item requirements. The individual item requirements shall be in accordance with MIL-PRF-38535, appendix A for non-JAN class level B devices and as specified herein. Product built to this drawing that is produced by a Qualified Manufacturer Listing (QML) certified and qualified manufacturer or a manufacturer who has been granted transitional certification to MIL-PRF-38535 may be processed as QML product in accordance with the manufacturers approved program plan and qualifying activity approval in accordance with MIL-PRF-38535. This QML flow as documented in the Quality Management (QM) plan may make modifications to the requirements herein. These modifications shall not affect form, fit, or function of the device. These modifications shall not affect the PIN as described herein. A "Q" or "QML" certification mark in accordance with MIL-PRF-38535 is required to identify when the QML flow option is used.

3.2 Design, construction, and physical dimensions. The design, construction, and physical dimensions shall be as specified in MIL-PRF-38535, appendix A and herein.

3.2.1 Case outline. The case outline shall be in accordance with 1.2.2 and figure 1 herein.

3.2.2 Terminal connections. The terminal connections shall be as specified on figure 2.

3.3 Electrical performance characteristics. Unless otherwise specified herein, the electrical performance characteristics are as specified in table I and shall apply over the full ambient operating temperature range.

3.4 Electrical test requirements. The electrical test requirements shall be the subgroups specified in table II. The electrical tests for each subgroup are described in table I.

STANDARD MICROCIRCUIT DRAWING DLA LAND AND MARITIME COLUMBUS, OHIO 43218-3990	SIZE A		77028
		REVISION LEVEL H	SHEET 3

TABLE I. Electrical performance characteristics.

Test	Symbol	Conditions ^{1/} -55°C ≤ T _A ≤ +125°C unless otherwise specified	Group A subgroups	Device type	Limits		Unit
					Min	Max	
Reference breakdown voltage	V _B	400 μA ≤ I _R ≤ 3.0 mA, T _A = +25°C	1	01	1.62	1.98	V
				02	1.80	2.20	
				03	1.98	2.42	
				04	2.16	2.64	
				05	2.43	2.97	
				06	2.70	3.30	
				07	2.97	3.63	
				08	3.24	3.96	
				09	3.51	4.29	
				10	3.87	4.73	
				11	4.23	5.17	
				12	4.59	5.61	
				13	5.04	6.16	
Reference breakdown voltage change	ΔV _B / ΔI _R	10 μA ≤ I _R ≤ 100 μA	1	All		120	mV
			2,3			200	
		100 μA ≤ I _R ≤ 1 mA	1			50	
			2			70	
			3			60	
		1 mA ≤ I _R ≤ 5 mA	1			150	
			2,3			200	
		Reverse breakdown ^{2/} voltage temperature coefficient	ΔV _B / Δt			100 μA ≤ I _R ≤ 1 mA	
Reverse leakage current	I _L	V _R = V _B - 0.2 V	1	All		5.0	μA
			2,3			50	
Forward voltage drop	V _F	I _F = 5 mA	1	All	-0.7	-1.0	V
			2,3		-0.05	-1.5	
Reverse dynamic ^{3/} resistance	R _R	I _{R1} = 3.15 mA, I _{R2} = 2.85 mA, T _A = +25°C	4	All		25	Ω

^{1/} Unless otherwise stated, -55°C ≤ T_A ≤ +125°C. The diode should not be operated with shunt capacitance between 100 pF and 0.01 μF unless isolated by at least 270 Ω resistor or oscillation may occur.

^{2/} If not tested shall be guaranteed to specified limits herein.

^{3/} Reverse dynamic resistance (R_R) is defined as (V_{B1} - V_{B2}) / (I_{R1} - I_{R2}) where V_{B1} is voltage across the device under test when reverse current is equal to I_{R1} and V_{B2} is voltage across the device under test when reverse current is equal to I_{R2}.

**STANDARD
MICROCIRCUIT DRAWING**
DLA LAND AND MARITIME
COLUMBUS, OHIO 43218-3990

SIZE
A

77028

REVISION LEVEL
H

SHEET
4

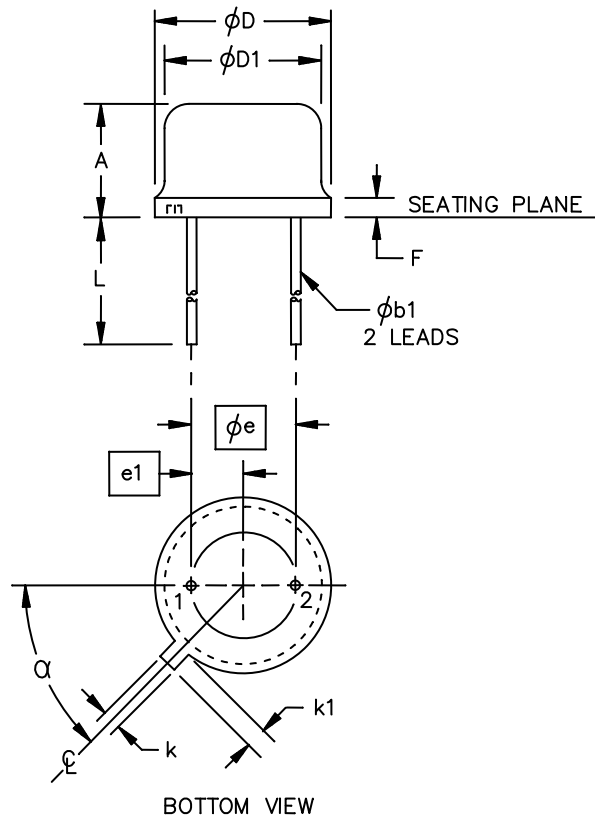

Symbol	Inches		Millimeters	
	Min	Max	Min	Max
A	.080	.105	2.03	2.67
ϕb_1	.012	.019	0.30	0.48
ϕD	.209	.230	5.31	5.84
ϕD_1	.178	.195	4.52	4.95
ϕe	.100 BSC		2.54 BSC	
e_1	.050 BSC		1.27 BSC	
F	---	.040	---	1.02
k	.036	.046	0.91	1.17
k_1	.028	.048	0.71	1.22
L	.500	.750	12.70	19.05
α	45° BSC		45° BSC	

NOTES:

1. Dimensions are in inches.
2. Metric equivalents are given for general information only.

FIGURE 1. Case outline.

**STANDARD
MICROCIRCUIT DRAWING**
DLA LAND AND MARITIME
COLUMBUS, OHIO 43218-3990

SIZE
A

77028

REVISION LEVEL
H

SHEET
5

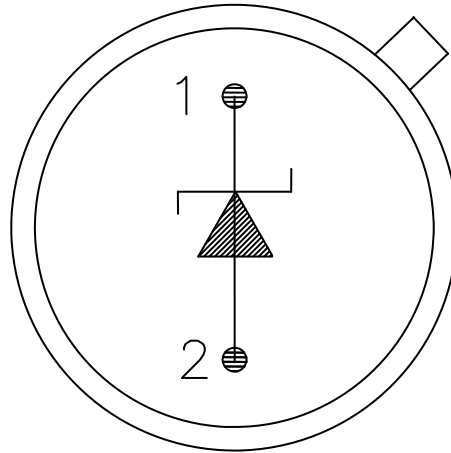

TOP VIEW

NOTE: Pin 2 is connected to case.

FIGURE 2. Terminal connections.

STANDARD MICROCIRCUIT DRAWING DLA LAND AND MARITIME COLUMBUS, OHIO 43218-3990	SIZE A		77028
		REVISION LEVEL H	SHEET 6

3.5 Marking. Marking shall be in accordance with MIL-PRF-38535, appendix A. The part shall be marked with the PIN listed in 1.2 herein. In addition, the manufacturer's PIN may also be marked.

3.5.1 Certification/compliance mark. A compliance indicator "C" shall be marked on all non-JAN devices built in compliance to MIL-PRF-38535, appendix A. The compliance indicator "C" shall be replaced with a "Q" or "QML" certification mark in accordance with MIL-PRF-38535 to identify when the QML flow option is used.

3.6 Certificate of compliance. A certificate of compliance shall be required from a manufacturer in order to be listed as an approved source of supply in MIL-HDBK-103 (see 6.6 herein). The certificate of compliance submitted to DLA Land and Maritime -VA prior to listing as an approved source of supply shall affirm that the manufacturer's product meets the requirements of MIL-PRF-38535, appendix A and the requirements herein.

3.7 Certificate of conformance. A certificate of conformance as required in MIL-PRF-38535, appendix A shall be provided with each lot of microcircuits delivered to this drawing.

3.8 Notification of change. Notification of change to DLA Land and Maritime -VA shall be required for any change that affects this drawing.

3.9 Verification and review. DLA Land and Maritime, DLA Land and Maritime 's agent, and the acquiring activity retain the option to review the manufacturer's facility and applicable required documentation. Offshore documentation shall be made available onshore at the option of the reviewer.

4. VERIFICATION

4.1 Sampling and inspection. Sampling and inspection procedures shall be in accordance with MIL-PRF-38535, appendix A.

4.2 Screening. Screening shall be in accordance with method 5004 of MIL-STD-883, and shall be conducted on all devices prior to quality conformance inspection. The following additional criteria shall apply:

a. Burn-in test, method 1015 of MIL-STD-883.

(1) Test condition A, B, C, or D. The test circuit shall be maintained by the manufacturer under document revision level control and shall be made available to the preparing or acquiring activity upon request. The test circuit shall specify the inputs, outputs, biases, and power dissipation, as applicable, in accordance with the intent specified in method 1015 of MIL-STD-883.

(2) $T_A = +125^{\circ}\text{C}$, minimum.

b. Interim and final electrical test parameters shall be as specified in table II herein, except interim electrical parameter tests prior to burn-in are optional at the discretion of the manufacturer.

4.3 Quality conformance inspection. Quality conformance inspection shall be in accordance with method 5005 of MIL-STD-883 including groups A, B, C, and D inspections. The following additional criteria shall apply.

4.3.1 Group A inspection.

a. Tests shall be as specified in table II herein.

b. Subgroups 5, 6, 7, 8, 9, 10, and 11 in table I, method 5005 of MIL-STD-883 shall be omitted.

STANDARD MICROCIRCUIT DRAWING DLA LAND AND MARITIME COLUMBUS, OHIO 43218-3990	SIZE A		77028
		REVISION LEVEL H	SHEET 7

TABLE II. Electrical test requirements.

MIL-STD-883 test requirements	Subgroups (in accordance with MIL-STD-883, method 5005, table I)
Interim electrical parameters (method 5004)	1
Final electrical test parameters (method 5004)	1*, 2, 3, 4
Group A test requirements (method 5005)	1, 2, 3, 4
Groups C and D end-point electrical parameters (method 5005)	1

* PDA applies to subgroup 1.

4.3.2 Groups C and D inspections.

- a. End-point electrical parameters shall be as specified in table II herein.
- b. Steady-state life test conditions, method 1005 of MIL-STD-883.
 - (1) Test condition A, B, C, or D. The test circuit shall be maintained by the manufacturer under document revision level control and shall be made available to the preparing or acquiring activity upon request. The test circuit shall specify the inputs, outputs, biases, and power dissipation, as applicable, in accordance with the intent specified in method 1005 of MIL-STD-883.
 - (2) $T_A = +125^{\circ}\text{C}$, minimum.
 - (3) Test duration: 1,000 hours, except as permitted by method 1005 of MIL-STD-883.

5. PACKAGING

5.1 Packaging requirements. The requirements for packaging shall be in accordance with MIL-PRF-38535, appendix A.

6. NOTES

6.1 Intended use. Microcircuits conforming to this drawing are intended for use for Government microcircuit applications (original equipment), design applications, and logistics purposes.

6.2 Replaceability. Microcircuits covered by this drawing will replace the same generic device covered by a contractor-prepared specification or drawing.

6.3 Configuration control of SMD's. All proposed changes to existing SMD's will be coordinated with the users of record for the individual documents. This coordination will be accomplished using DD Form 1692, Engineering Change Proposal.

6.4 Record of users. Military and industrial users shall inform DLA Land and Maritime when a system application requires configuration control and the applicable SMD to that system. DLA Land and Maritime will maintain a record of users and this list will be used for coordination and distribution of changes to the drawings. Users of drawings covering microelectronics devices (FSC 5962) should contact DLA Land and Maritime -VA, telephone (614) 692-0544.

STANDARD MICROCIRCUIT DRAWING DLA LAND AND MARITIME COLUMBUS, OHIO 43218-3990	SIZE A		77028
		REVISION LEVEL H	SHEET 8

6.5 Comments. Comments on this drawing should be directed to DLA Land and Maritime -VA, Columbus, Ohio 43218-3990, or telephone (614) 692-0540.

6.6 Approved sources of supply. Approved sources of supply are listed in MIL-HDBK-103. The vendors listed in MIL-HDBK-103 have agreed to this drawing and a certificate of compliance (see 3.6 herein) has been submitted to and accepted by DLA Land and Maritime -VA.

STANDARD MICROCIRCUIT DRAWING DLA LAND AND MARITIME COLUMBUS, OHIO 43218-3990	SIZE A		77028
		REVISION LEVEL H	SHEET 9

STANDARD MICROCIRCUIT DRAWING BULLETIN

DATE: 11-06-07

Approved sources of supply for SMD 77028 are listed below for immediate acquisition information only and shall be added to MIL-HDBK-103 and QML-38535 during the next revision. MIL-HDBK-103 and QML-38535 will be revised to include the addition or deletion of sources. The vendors listed below have agreed to this drawing and a certificate of compliance has been submitted to and accepted by DLA Land and Maritime -VA. This information bulletin is superseded by the next dated revision of MIL-HDBK-103 and QML-38535. DLA Land and Maritime maintains an online database of all current sources of supply at <http://www.dsccl.dla.mil/Programs/Smcr/>.

Standard microcircuit drawing PIN <u>1/</u>	Vendor CAGE number	Vendor similar PIN <u>2/</u>
7702801XA	<u>3/</u>	SG103Z-1.8
	<u>3/</u>	TSC103H-1.8MRM
7702802XA	<u>3/</u>	LM103H-2.0
7702803XA	<u>3/</u>	LM103H-2.2
7702804XA	<u>3/</u>	LM103H-2.4
7702805XA	<u>3/</u>	SG103Z-2.7
7702806XA	3V146	LM103H-3.0/883
7702807XA	3V146	LM103H-3.3/883
7702808XA	<u>3/</u>	LM103H-3.6
7702809XA	<u>3/</u>	LM103H-3.9
7702810XA	<u>3/</u>	LM103H-4.3
7702811XA	<u>3/</u>	SG103Z-4.7
7702812XA	<u>3/</u>	LM103H-5.1
7702813XA	<u>3/</u>	LM103H-5.6

- 1/ The lead finish shown for each PIN representing a hermetic package is the most readily available from the manufacturer listed for that part. If the desired lead finish is not listed contact the vendor to determine its availability.
- 2/ Caution. Do not use this number for item acquisition. Items acquired to this number may not satisfy the performance requirements of this drawing.
- 3/ Not available from an approved source of supply.

Vendor CAGE
number

3V146

Vendor name
and address

Rochester Electronics Inc.
16 Malcolm Hoyt Drive
Newburyport, MA 01950

The information contained herein is disseminated for convenience only and the Government assumes no liability whatsoever for any inaccuracies in the information bulletin.