

REVISIONS

LTR	DESCRIPTION	DATE (YR-MO-DA)	APPROVED
A	Update drawing to current requirements. Editorial changes throughout. - drw	05-06-08	Raymond Monnin

THE FIRST SHEET OF THIS DRAWING HAS BEEN REPLACED.

REV																				
SHEET																				
REV																				
SHEET																				

REV STATUS	REV	A	A	A	A	A	A	A	A	A	A	A	A	A	A	A	A	A	A	
OF SHEETS	SHEET	1	2	3	4	5	6	7	8	9	10									

PMIC N/A <p style="text-align: center;">STANDARD MICROCIRCUIT DRAWING</p> <p style="text-align: center;">THIS DRAWING IS AVAILABLE FOR USE BY ALL DEPARTMENTS AND AGENCIES OF THE DEPARTMENT OF DEFENSE</p> <p style="text-align: center;">AMSC N/A</p>	PREPARED BY <p style="text-align: center;">Joseph A. Kerby</p> <hr/> CHECKED BY <p style="text-align: center;">Charles Reusing</p> <hr/> APPROVED BY <p style="text-align: center;">Michael A. Frye</p> <hr/> DRAWING APPROVAL DATE <p style="text-align: center;">88-01-15</p> <hr/> REVISION LEVEL <p style="text-align: center;">A</p>	<p>DEFENSE SUPPLY CENTER COLUMBUS COLUMBUS, OHIO 43218-3990 http://www.dsccl.dla.mil</p> <hr/> <p>MICROCIRCUIT, LINEAR, QUAD THREE-STATE LINE DRIVER, MONOLITHIC SILICON</p> <hr/> <table style="width: 100%; border-collapse: collapse;"> <tr> <td style="width: 15%; text-align: center;">SIZE A</td> <td style="width: 25%; text-align: center;">CAGE CODE 67268</td> <td style="width: 60%; text-align: center;">5962-87670</td> </tr> </table> <hr/> SHEET 1 OF 10	SIZE A	CAGE CODE 67268	5962-87670
SIZE A	CAGE CODE 67268	5962-87670			

1. SCOPE

1.1 Scope. This drawing describes device requirements for MIL-STD-883 compliant, non-JAN class level B microcircuits in accordance with MIL-PRF-38535, appendix A.

1.2 Part or Identifying Number (PIN). The complete PIN is as shown in the following example:

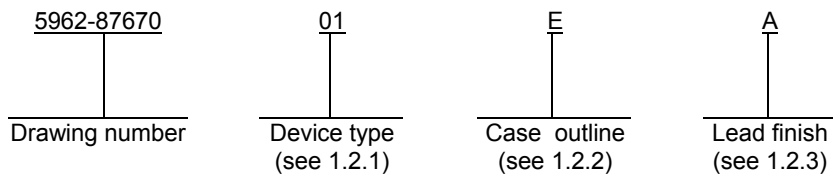

1.2.1 Device type. The device type identify the circuit function as follows:

<u>Device type</u>	<u>Generic number</u>	<u>Circuit function</u>
01	26LS29	Quad three-state RS-423 line driver

1.2.2 Case outlines. The case outlines are as designated in MIL-STD-1835 and as follows:

<u>Outline letter</u>	<u>Descriptive designator</u>	<u>Terminals</u>	<u>Package style</u>
E	GDIP1-T16 or CDIP2-T16	16	Dual-in-line
F	GDFP2-F16 or CDFP3-F16	16	Flat pack

1.2.3 Lead finish. The lead finish is as specified in MIL-PRF-38535, appendix A.

1.3 Absolute maximum ratings.

Supply voltage range (V_{CC})	-0.5 V dc to +7.0 V dc
Supply voltage range (V_{EE})	+0.5 V dc to -7.0 V dc
Input voltage range	-1.5 V dc to +15.0 V dc
Storage temperature range	-65°C to +150°C
Maximum power dissipation P_D ^{1/}	600 mW
Lead temperature (soldering, 10 seconds)	+300°C
Thermal resistance, junction-to-case (θ_{JC}):	
Cases E and F	See MIL-STD-1835
Junction temperature (T_J)	+175°C
Thermal resistance, junction-to-ambient (θ_{JA}):	
Cases E and F	89°C/W maximum

1.4 Recommended operating conditions.

Supply voltage (V_{CC})	+4.75 V dc to +5.5 V dc
Supply voltage (V_{EE})	-4.75 V dc to -5.5 V dc
Minimum high level input voltage (V_{IH})	2.0 V dc
Maximum low level input voltage (V_{IL})	0.8 V dc
Ambient operating temperature range (T_A)	-55°C to +125°C

^{1/} Must withstand the added P_D due to short circuit test; e.g., I_{OS} .

STANDARD MICROCIRCUIT DRAWING DEFENSE SUPPLY CENTER COLUMBUS COLUMBUS, OHIO 43218-3990	SIZE A		5962-87670
		REVISION LEVEL A	SHEET 2

2. APPLICABLE DOCUMENTS

2.1 Government specification, standards, and handbooks. The following specification, standards, and handbooks form a part of this drawing to the extent specified herein. Unless otherwise specified, the issues of these documents are those cited in the solicitation or contract.

DEPARTMENT OF DEFENSE SPECIFICATION

MIL-PRF-38535 - Integrated Circuits, Manufacturing, General Specification for.

DEPARTMENT OF DEFENSE STANDARDS

MIL-STD-883 - Test Method Standard Microcircuits.
 MIL-STD-1835 - Interface Standard Electronic Component Case Outlines.

DEPARTMENT OF DEFENSE HANDBOOKS

MIL-HDBK-103 - List of Standard Microcircuit Drawings.
 MIL-HDBK-780 - Standard Microcircuit Drawings.

(Copies of these documents are available online at <http://assist.daps.dla.mil/quicksearch/> or <http://assist.daps.dla.mil> or from the Standardization Document Order Desk, 700 Robbins Avenue, Building 4D, Philadelphia, PA 19111-5094.)

2.2 Order of precedence. In the event of a conflict between the text of this drawing and the references cited herein, the text of this drawing takes precedence. Nothing in this document, however, supersedes applicable laws and regulations unless a specific exemption has been obtained.

3. REQUIREMENTS

3.1 Item requirements. The individual item requirements shall be in accordance with MIL-PRF-38535, appendix A for non-JAN class level B devices and as specified herein. Product built to this drawing that is produced by a Qualified Manufacturer Listing (QML) certified and qualified manufacturer or a manufacturer who has been granted transitional certification to MIL-PRF-38535 may be processed as QML product in accordance with the manufacturers approved program plan and qualifying activity approval in accordance with MIL-PRF-38535. This QML flow as documented in the Quality Management (QM) plan may make modifications to the requirements herein. These modifications shall not affect form, fit, or function of the device. These modifications shall not affect the PIN as described herein. A "Q" or "QML" certification mark in accordance with MIL-PRF-38535 is required to identify when the QML flow option is used.

3.2 Design, construction, and physical dimensions. The design, construction, and physical dimensions shall be as specified in MIL-PRF-38535, appendix A and herein.

3.2.1 Case outlines. The case outlines shall be in accordance with 1.2.2 herein.

3.2.2 Terminal connections. The terminal connections shall be as specified on figure 1

3.2.3 Block diagram. The block diagram shall be as specified on figure 2

3.2.4 Waveforms. The waveforms shall be as specified on figure 3.

3.3 Electrical performance characteristics. Unless otherwise specified herein, the electrical performance characteristics are as specified in table I and shall apply over the full ambient operating temperature range.

3.4 Electrical test requirements. The electrical test requirements shall be the subgroups specified in table II. The electrical tests for each subgroup are described in table I.

3.5 Marking. Marking shall be in accordance with MIL-PRF-38535, appendix A. The part shall be marked with the PIN listed in 1.2 herein. In addition, the manufacturer's PIN may also be marked. For packages where marking of the entire SMD PIN number is not feasible due to space limitations, the manufacturer has the option of not marking the "5962-" on the device.

3.5.1 Certification/compliance mark. A compliance indicator "C" shall be marked on all non-JAN devices built in compliance to MIL-PRF-38535, appendix A. The compliance indicator "C" shall be replaced with a "Q" or "QML" certification mark in accordance with MIL-PRF-38535 to identify when the QML flow option is used.

STANDARD MICROCIRCUIT DRAWING DEFENSE SUPPLY CENTER COLUMBUS COLUMBUS, OHIO 43218-3990	SIZE A		5962-87670
		REVISION LEVEL A	SHEET 3

TABLE I. Electrical performance characteristics.

Test	Symbol	Conditions -55°C ≤ T _A ≤ +125°C +4.75 V ≤ V _{CC} ≤ +5.5 V -4.75 V ≤ V _{EE} ≤ -5.5 V unless otherwise specified 1/		Group A subgroups	Device type	Limits		Unit
						Min	Max	
High level output voltage	V _{OH}	R _L = ∞ 2/	V _{IH} = 2.4 V	1, 2, 3	All	4.0	6.0	V
Low level output voltage	V _{OL}		V _{CC} = V _{EE} = 4.75 V			V _{IL} = 0.4 V	-4.0	
Output voltage 3/	V _T	R _L = 450Ω	V _{IN} = 2.4 V	1, 2, 3	All	3.6		V
	$\overline{V_T}$	V _{CC} = V _{EE} = 4.75 V	V _{IN} = 0.4 V			-3.6		
Output unbalance 3/	$\frac{ V_T - V_T }{ V_T }$	R _L = 450Ω, V _{CC} = V _{EE}		1, 2, 3	All		0.4	V
Output leakage power off	I _{X+}	V _{CC} = V _{EE} = 0 V	V _{OUT} = 10.0 V	1, 2, 3	All		100	μA
	I _{X-}		V _{OUT} = -10.0 V				-100	
Output short circuit current 4/	I _{OS+}	V _{OUT} = 0 V	V _{IN} = 2.4 V	1, 2, 3	All	-20	-150	mA
	I _{OS-}	V _{CC} = V _{EE} = 5.5 V	V _{IN} = 0.4 V			20	150	
Off-state output current (high impedance)	I _{O+}	V _{CC} = V _{EE} = 5.5 V	V _{OUT} = 10.0 V	1, 2, 3	All		100	μA
	I _{O-}		V _{OUT} = -10.0 V				-100	
Positive supply current	I _{CC}	V _{IN} = 0.4 V, R _L = ∞, V _{CC} = V _{EE} = 5.5 V		1, 2, 3	All		30	mA
Negative supply current	I _{EE}	V _{IN} = 0.4 V, R _L = ∞, V _{CC} = V _{EE} = 5.5 V		1, 2, 3	All		-22	mA
Input high current	I _{IH}	V _{CC} = V _{EE} = 5.5 V, V _{IN} = 2.4 V		1, 2, 3	All		40	μA
		V _{CC} = 5.5 V, V _{EE} = -5.0 V, V _{IN} = 15 V					100	
Input low current	I _{IL}	V _{CC} = V _{EE} = 5.5 V, V _{IN} = 0.4 V		1, 2, 3	All		-200	μA
Input clamp voltage	V _{IC}	V _{CC} = 4.75 V, V _{EE} = -4.75 V, I _{IN} = -12 mA		1, 2, 3	All		-1.5	V
Rise time	t _R	R _L = 450Ω, C _L = 500 pF, C _C = 0 pF, See rise time control, figure 3		9 5/	All		300	ns
				10, 11			450	
Fall time	t _F	R _L = 450Ω, C _L = 500 pF, C _C = 0 pF, See rise time control, figure 3		9 5/	All		300	ns
				10, 11			450	

See footnotes at end of table.

STANDARD MICROCIRCUIT DRAWING DEFENSE SUPPLY CENTER COLUMBUS COLUMBUS, OHIO 43218-3990	SIZE A		5962-87670
		REVISION LEVEL A	SHEET 4

TABLE I. Electrical performance characteristics - continued.

Test	Symbol	Conditions -55°C ≤ T _A ≤ +125°C +4.75 V ≤ V _{CC} ≤ +5.5 V -4.75 V ≤ V _{EE} ≤ -5.5 V unless otherwise specified ^{1/}	Group A subgroups	Device type	Limits		Unit
					Min	Max	
Output high propagation delay	t _{PDH}	R _L = 450Ω, C _L = 500 pF, C _C = 0 pF, See rise time control, figure 3	9 ^{5/}	All		300	ns
			10, 11			450	
Output low propagation delay	t _{PDL}	R _L = 450Ω, C _L = 500 pF, C _C = 0 pF, See rise time control, figure 3	9 ^{5/}	All		300	ns
			10, 11			450	
Output enable to output delay	t _{LZ}	R _L = 100Ω, C _L = 500 pF, C _C = 0 pF	9 ^{5/}	All		300	ns
			10, 11			400	
	t _{HZ}		9 ^{5/}			350	
			10, 11			400	
	t _{ZL}		9 ^{5/}			350	
			10, 11			400	
	t _{ZH}		9 ^{5/}			300	
			10, 11			400	

^{1/} Symbols and definition correspond to EIA RS-423 where applicable.

^{2/} Output voltage is +3.9 V minimum for V_{OH} and -3.9 V minimum for V_{OL} at -55°C.

^{3/} This parameter is tested by forcing an equivalent current.

^{4/} Not more than one output should be shorted at a time and the duration of the short circuit condition should not exceed one second.

^{5/} Supply voltage V_{CC} 5.0 V, supply voltage V_{EE} = -5.0 V.

STANDARD MICROCIRCUIT DRAWING DEFENSE SUPPLY CENTER COLUMBUS COLUMBUS, OHIO 43218-3990	SIZE A		5962-87670
		REVISION LEVEL A	SHEET 5

Device type	01
Case outlines	E and F
Terminal number	Terminal symbol
1	V_{CC}
2	INPUT A
3	INPUT B
4	$\overline{\text{ENABLE}}$
5	GND
6	INPUT C
7	INPUT D
8	V_{EE}
9	SLEW RATE CONTROL D
10	OUTPUT D
11	OUTPUT C
12	SLEW RATE CONTROL C
13	SLEW RATE CONTROL B
14	OUTPUT B
15	OUTPUT A
16	SLEW RATE CONTROL A

FIGURE 1. Terminal connections.

STANDARD MICROCIRCUIT DRAWING DEFENSE SUPPLY CENTER COLUMBUS COLUMBUS, OHIO 43218-3990	SIZE A		5962-87670
		REVISION LEVEL A	SHEET 6

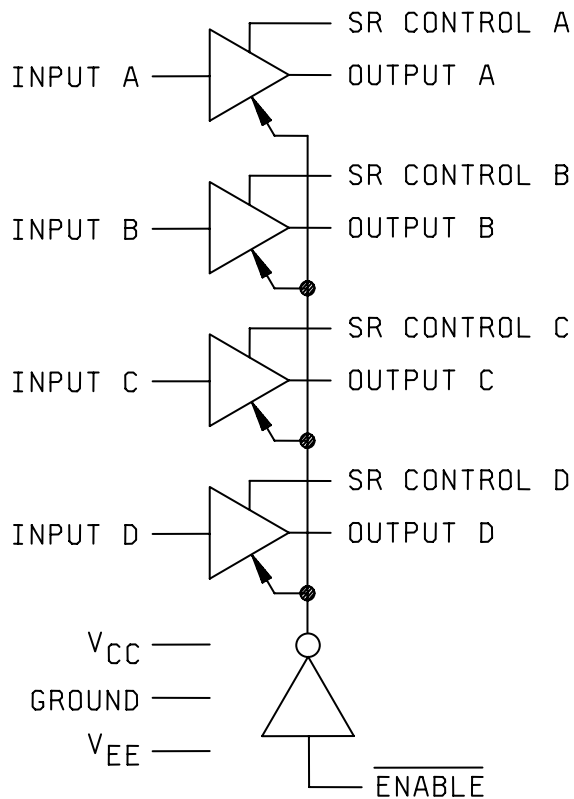
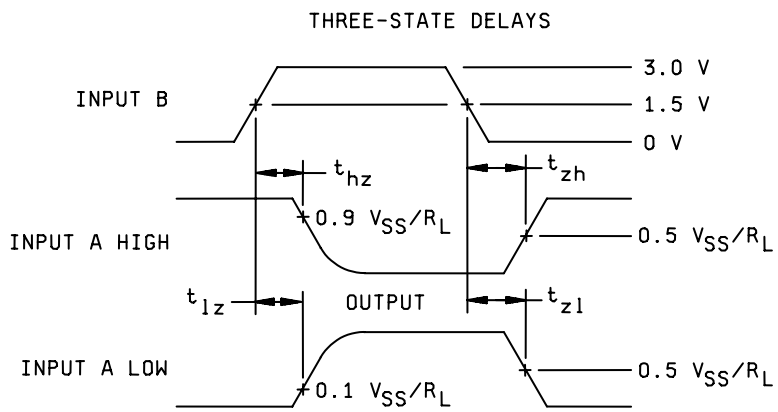
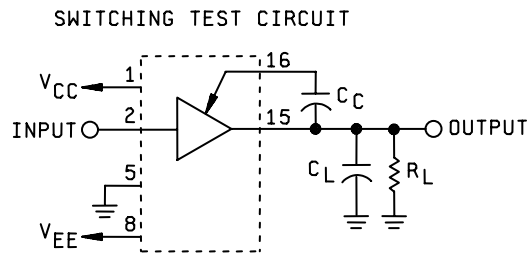
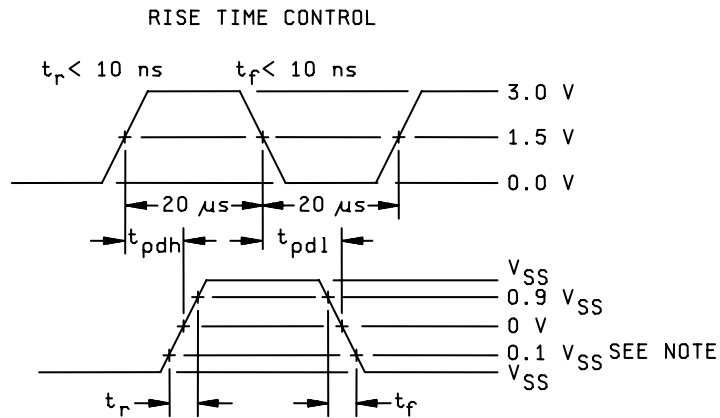

FIGURE 2. Block diagram.

STANDARD MICROCIRCUIT DRAWING DEFENSE SUPPLY CENTER COLUMBUS COLUMBUS, OHIO 43218-3990	SIZE A		5962-87670
		REVISION LEVEL A	SHEET 7



NOTE: V_{SS} means steady-state swing voltage and is defined as equal to $|\overline{V_T} - \underline{V_T}|$.

FIGURE 3. Waveforms.

STANDARD MICROCIRCUIT DRAWING DEFENSE SUPPLY CENTER COLUMBUS COLUMBUS, OHIO 43218-3990	SIZE A		5962-87670
		REVISION LEVEL A	SHEET 8

3.6 Certificate of compliance. A certificate of compliance shall be required from a manufacturer in order to be listed as an approved source of supply in MIL-HDBK-103 (see 6.6 herein). The certificate of compliance submitted to DSCC-VA prior to listing as an approved source of supply shall affirm that the manufacturer's product meets the requirements of MIL-PRF-38535, appendix A and the requirements herein.

3.7 Certificate of conformance. A certificate of conformance as required in MIL-PRF-38535, appendix A shall be provided with each lot of microcircuits delivered to this drawing.

3.8 Notification of change. Notification of change to DSCC-VA shall be required for any change that affects this drawing.

3.9 Verification and review. DSCC, DSCC's agent, and the acquiring activity retain the option to review the manufacturer's facility and applicable required documentation. Offshore documentation shall be made available onshore at the option of the reviewer.

4. VERIFICATION

4.1 Sampling and inspection. Sampling and inspection procedures shall be in accordance with MIL-PRF-38535, appendix A.

4.2 Screening. Screening shall be in accordance with method 5004 of MIL-STD-883, and shall be conducted on all devices prior to quality conformance inspection. The following additional criteria shall apply:

- a. Burn-in test, method 1015 of MIL-STD-883.
 - (1) Test condition A, B, C, or D. The test circuit shall be maintained by the manufacturer under document revision level control and shall be made available to the preparing or acquiring activity upon request. The test circuit shall specify the inputs, outputs, biases, and power dissipation, as applicable, in accordance with the intent specified in method 1015 of MIL-STD-883.
 - (2) $T_A = +125^{\circ}\text{C}$, minimum.
- b. Interim and final electrical test parameters shall be as specified in table II herein, except interim electrical parameter tests prior to burn-in are optional at the discretion of the manufacturer.

4.3 Quality conformance inspection. Quality conformance inspection shall be in accordance with method 5005 of MIL-STD-883 including groups A, B, C, and D inspections. The following additional criteria shall apply.

4.3.1 Group A inspection.

- a. Tests shall be as specified in table II herein.
- b. Subgroups 4, 5, 6, 7, and 8 in table I, method 5005 of MIL-STD-883 shall be omitted.

4.3.2 Groups C and D inspections.

- a. End-point electrical parameters shall be as specified in table II herein.
- b. Steady-state life test conditions, method 1005 of MIL-STD-883.
 - (1) Test condition A, B, C, or D. The test circuit shall be maintained by the manufacturer under document revision level control and shall be made available to the preparing or acquiring activity upon request. The test circuit shall specify the inputs, outputs, biases, and power dissipation, as applicable, in accordance with the intent specified in method 1005 of MIL-STD-883.
 - (2) $T_A = +125^{\circ}\text{C}$, minimum.
 - (3) Test duration: 1,000 hours, except as permitted by method 1005 of MIL-STD-883.

STANDARD MICROCIRCUIT DRAWING DEFENSE SUPPLY CENTER COLUMBUS COLUMBUS, OHIO 43218-3990	SIZE A		5962-87670
		REVISION LEVEL A	SHEET 9

TABLE II. Electrical test requirements.

MIL-STD-883 test requirements	Subgroups (in accordance with MIL-STD-883, method 5005, table I)
Interim electrical parameters (method 5004)	---
Final electrical test parameters (method 5004)	1*, 2, 3, 9, 10**, 11**
Group A test requirements (method 5005)	1, 2, 3, 9, 10**, 11**
Groups C and D end-point electrical parameters (method 5005)	1, 2, 3

* PDA applies to subgroup 1.

** Subgroups 10 and 11, if not tested, shall be guaranteed to the limits specified in table I.

5. PACKAGING

5.1 Packaging requirements. The requirements for packaging shall be in accordance with MIL-PRF-38535, appendix A.

6. NOTES

6.1 Intended use. Microcircuits conforming to this drawing are intended for use for Government microcircuit applications (original equipment), design applications, and logistics purposes.

6.2 Replaceability. Microcircuits covered by this drawing will replace the same generic device covered by a contractor-prepared specification or drawing.

6.3 Configuration control of SMD's. All proposed changes to existing SMD's will be coordinated with the users of record for the individual documents. This coordination will be accomplished using DD Form 1692, Engineering Change Proposal.

6.4 Record of users. Military and industrial users shall inform Defense Supply Center Columbus (DSCC) when a system application requires configuration control and the applicable SMD. DSCC will maintain a record of users and this list will be used for coordination and distribution of changes to the drawings. Users of drawings covering microelectronics devices (FSC 5962) should contact DSCC-VA, telephone (614) 692-0544.

6.5 Comments. Comments on this drawing should be directed to DSCC-VA, Columbus, Ohio 43218-3990, or telephone (614) 692-0547.

6.6 Approved sources of supply. Approved sources of supply are listed in MIL-HDBK-103. The vendors listed in MIL-HDBK-103 have agreed to this drawing and a certificate of compliance (see 3.6 herein) has been submitted to and accepted by DSCC-VA.

STANDARD MICROCIRCUIT DRAWING DEFENSE SUPPLY CENTER COLUMBUS COLUMBUS, OHIO 43218-3990	SIZE A		5962-87670
		REVISION LEVEL A	SHEET 10

STANDARD MICROCIRCUIT DRAWING BULLETIN

DATE: 05-06-08

Approved sources of supply for SMD 5962-87670 are listed below for immediate acquisition information only and shall be added to MIL-HDBK-103 and QML-38535 during the next revision. MIL-HDBK-103 and QML-38535 will be revised to include the addition or deletion of sources. The vendors listed below have agreed to this drawing and a certificate of compliance has been submitted to and accepted by DSCC-VA. This information bulletin is superseded by the next dated revision of MIL-HDBK-103 and QML-38535. DSCC maintains an online database of all current sources of supply at <http://www.dscclia.mil/Programs/Smcr/>.

Standard microcircuit drawing PIN <u>1/</u>	Vendor CAGE number	Vendor similar PIN <u>2/</u>
5962-8767001EA	3V146	26LS29/BEA
	<u>3/</u>	Am26LS29/BEA
5962-8767001FA	3V146	26LS29/BFA
	<u>3/</u>	Am26LS29/BFA

- 1/ The lead finish shown for each PIN representing a hermetic package is the most readily available from the manufacturer listed for that part. If the desired lead finish is not listed contact the vendor to determine its availability.
- 2/ Caution. Do not use this number for item acquisition. Items acquired to this number may not satisfy the performance requirements of this drawing.
- 3/ Not available from an approved source of supply.

Vendor CAGE number

3V146

Vendor name and address

Rochester Electronics
10 Malcolm Hoyt Drive
Newburyport, MA 01950

The information contained herein is disseminated for convenience only and the Government assumes no liability whatsoever for any inaccuracies in the information bulletin.