

REVISIONS			
LTR	DESCRIPTION	DATE (YR-MO-DA)	APPROVED
A	Drawing updated to reflect current requirements. - ro	01-01-17	R. MONNIN
B	Make correction to max limit for V_{REF} in table I from 5.05 to 5.10. Replaced reference to MIL-STD-973 with reference to MIL-PRF-38535. -rrp	04-10-14	R. MONNIN
C	Update drawing to current requirements of MIL-PRF-38535. -rrp	11-07-19	C. SAFFLE

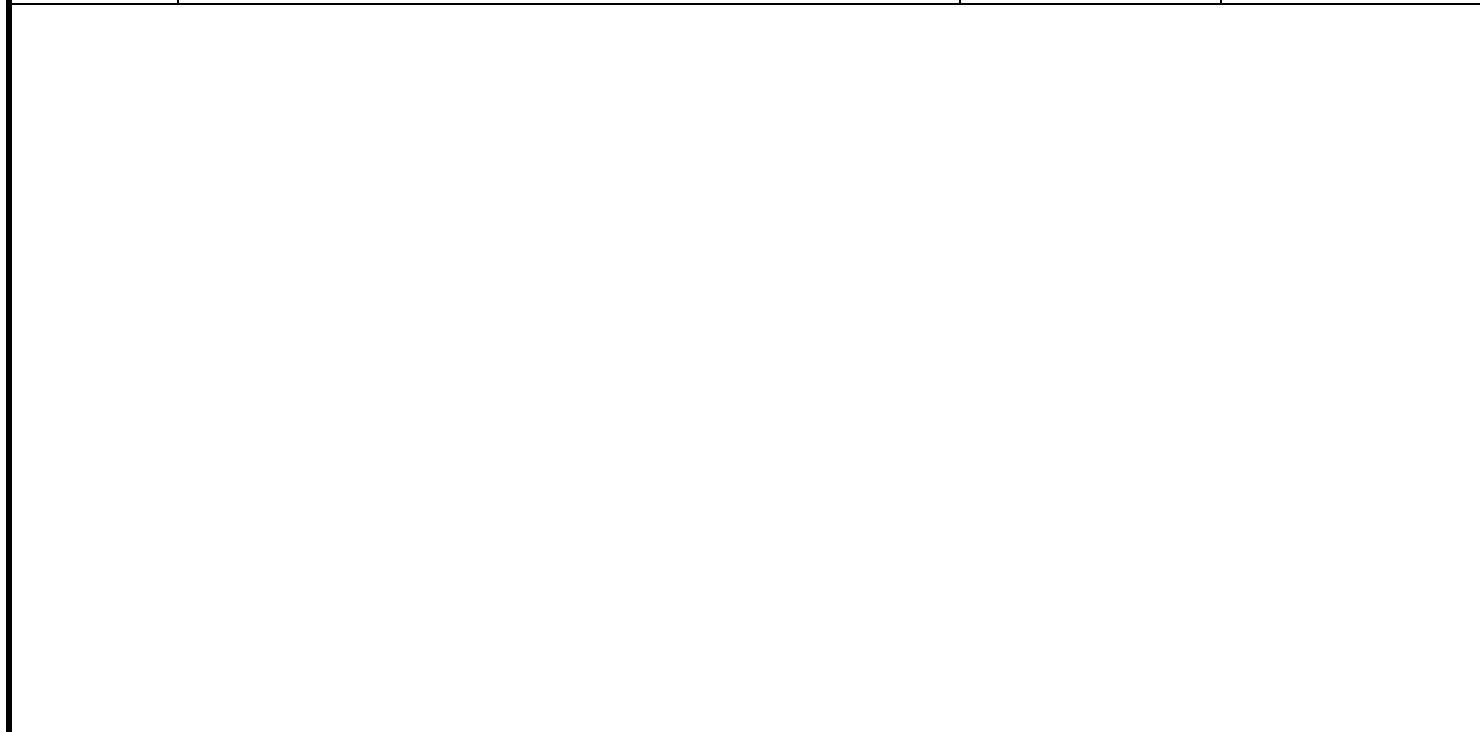

REV																				
SHEET																				
REV																				
SHEET																				

REV STATUS	REV	C	C	C	C	C	C	C	C	C	C	C	C	C	C	C	C	C	C	C
OF SHEETS	SHEET	1	2	3	4	5	6	7	8	9	10	11	12	13						

PMIC N/A	PREPARED BY MARCIA B. KELLEHER	DLA LAND AND MARITIME COLUMBUS, OHIO 43218-3990 http://www.landandmaritime.dla.mil																	
STANDARD MICROCIRCUIT DRAWING THIS DRAWING IS AVAILABLE FOR USE BY ALL DEPARTMENTS AND AGENCIES OF THE DEPARTMENT OF DEFENSE AMSC N/A	CHECKED BY SANDRA ROONEY																		
	APPROVED BY MICHAEL A. FRYE	MICROCIRCUIT, LINEAR, PROGRAMMABLE PULSE WIDTH MODULATOR, MONOLITHIC SILICON																	
	DRAWING APPROVAL DATE 93-08-25																		
	REVISION LEVEL C	SIZE A	CAGE CODE 67268	5962-89920															
		SHEET		1 OF 13															

1. SCOPE

1.1 Scope. This drawing describes device requirements for MIL-STD-883 compliant, non-JAN class level B microcircuits in accordance with MIL-PRF-38535, appendix A.

1.2 Part or Identifying Number (PIN). The complete PIN is as shown in the following example:

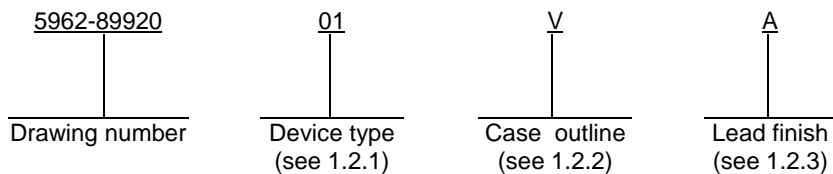

1.2.1 Device type(s). The device type(s) identify the circuit function as follows:

<u>Device type</u>	<u>Generic number</u>	<u>Circuit function</u>
01	UC1840	Programmable, off-line, PWM controller
02	UC1841	Programmable, off-line, PWM controller

1.2.2 Case outline(s). The case outline(s) are as designated in MIL-STD-1835 and as follows:

<u>Outline letter</u>	<u>Descriptive designator</u>	<u>Terminals</u>	<u>Package style</u>
V	GDIP1-T18 or CDIP2-T18	18	Dual-in-line
2	CQCC1-N20	20	Square leadless chip carrier

1.2.3 Lead finish. The lead finish is as specified in MIL-PRF-38535, appendix A.

1.3 Absolute maximum ratings. 1/

Input voltage (+V _{IN}):	
Voltage driven	+32 V dc
Current driven, 100 mA maximum	Self-limiting
PWM output voltage	40 V
PWM output current, steady-state	400 mA
PWM output peak energy discharge	20 μJ
Driver bias current	-200 mA
Reference output current	-50 mA
Slow-start sink current	20 mA
V _{IN} sense current	10 mA
Current limit inputs	-0.5 V to +5.5 V
Comparator inputs:	
Device type 01	-0.3 V to +32 V
Device type 02	Internally clamped at 12 V
Stop input, device type 02	-0.3 V to +5.5 V

1/ All voltages are with respect to GND. Currents are positive-into, negative-out of the specified terminal.

STANDARD MICROCIRCUIT DRAWING DLA LAND AND MARITIME COLUMBUS, OHIO 43218-3990	SIZE A		5962-89920
		REVISION LEVEL C	SHEET 2

1.3 Absolute maximum ratings – continued. 1/

Power dissipation, (P _D) T _A = 25°C	1 W <u>2/</u>
Power dissipation, (P _D) T _C = 25°C	2 W <u>3/</u>
Storage temperature range	-65°C to +150°C
Lead temperature (soldering, 10 seconds)	+300°C
Junction temperature (T _J)	+150°C
Thermal resistance, junction-to-case (θ _{JC})	See MIL-STD-1835
Thermal resistance, junction-to-ambient (θ _{JA})	100°C/W

1.4 Recommended operating conditions.

Input voltage (V _{IN})	20 V dc
Ambient operating temperature range (T _A)	-55°C to +125°C

2. APPLICABLE DOCUMENTS

2.1 Government specification, standards, and handbooks. The following specification, standards, and handbooks form a part of this drawing to the extent specified herein. Unless otherwise specified, the issues of these documents are those cited in the solicitation or contract.

DEPARTMENT OF DEFENSE SPECIFICATION

MIL-PRF-38535 - Integrated Circuits, Manufacturing, General Specification for.

DEPARTMENT OF DEFENSE STANDARDS

MIL-STD-883 - Test Method Standard Microcircuits.
 MIL-STD-1835 - Interface Standard Electronic Component Case Outlines.

DEPARTMENT OF DEFENSE HANDBOOKS

MIL-HDBK-103 - List of Standard Microcircuit Drawings.
 MIL-HDBK-780 - Standard Microcircuit Drawings.

(Copies of these documents are available online at <https://assist.daps.dla.mil/quicksearch/> or from the Standardization Document Order Desk, 700 Robbins Avenue, Building 4D, Philadelphia, PA 19111-5094.)

2.2 Order of precedence. In the event of a conflict between the text of this drawing and the references cited herein, the text of this drawing takes precedence. Nothing in this document, however, supersedes applicable laws and regulations unless a specific exemption has been obtained.

2/ Derate at 10 mW/°C for T_A above 50°C.
3/ Derate at 16 mW/°C for T_C above 25°C.

STANDARD MICROCIRCUIT DRAWING DLA LAND AND MARITIME COLUMBUS, OHIO 43218-3990	SIZE A		5962-89920
		REVISION LEVEL C	SHEET 3

3. REQUIREMENTS

3.1 Item requirements. The individual item requirements shall be in accordance with MIL-PRF-38535, appendix A for non-JAN class level B devices and as specified herein. Product built to this drawing that is produced by a Qualified Manufacturer Listing (QML) certified and qualified manufacturer or a manufacturer who has been granted transitional certification to MIL-PRF-38535 may be processed as QML product in accordance with the manufacturers approved program plan and qualifying activity approval in accordance with MIL-PRF-38535. This QML flow as documented in the Quality Management (QM) plan may make modifications to the requirements herein. These modifications shall not affect form, fit, or function of the device. These modifications shall not affect the PIN as described herein. A "Q" or "QML" certification mark in accordance with MIL-PRF-38535 is required to identify when the QML flow option is used.

3.2 Design, construction, and physical dimensions. The design, construction, and physical dimensions shall be as specified in MIL-PRF-38535, appendix A and herein.

3.2.1 Case outlines. The case outlines shall be in accordance with 1.2.2 herein.

3.2.2 Terminal connections. The terminal connections shall be as specified on figure 1.

3.2.3 Logic diagrams. The logic diagrams shall be as specified on figure 2.

3.3 Electrical performance characteristics. Unless otherwise specified herein, the electrical performance characteristics are as specified in table I and shall apply over the full ambient operating temperature range.

3.4 Electrical test requirements. The electrical test requirements shall be the subgroups specified in table II. The electrical tests for each subgroup are described in table I.

3.5 Marking. Marking shall be in accordance with MIL-PRF-38535, appendix A. The part shall be marked with the PIN listed in 1.2 herein. In addition, the manufacturer's PIN may also be marked. For packages where marking of the entire SMD PIN number is not feasible due to space limitations, the manufacturer has the option of not marking the "5962-" on the device.

3.5.1 Certification/compliance mark. A compliance indicator "C" shall be marked on all non-JAN devices built in compliance to MIL-PRF-38535, appendix A. The compliance indicator "C" shall be replaced with a "Q" or "QML" certification mark in accordance with MIL-PRF-38535 to identify when the QML flow option is used.

3.6 Certificate of compliance. A certificate of compliance shall be required from a manufacturer in order to be listed as an approved source of supply in MIL-HDBK-103 (see 6.6 herein). The certificate of compliance submitted to DLA Land and Maritime -VA prior to listing as an approved source of supply shall affirm that the manufacturer's product meets the requirements of MIL-PRF-38535, appendix A and the requirements herein.

3.7 Certificate of conformance. A certificate of conformance as required in MIL-PRF-38535, appendix A shall be provided with each lot of microcircuits delivered to this drawing.

3.8 Notification of change. Notification of change to DLA Land and Maritime -VA shall be required for any change that affects this drawing.

3.9 Verification and review. DLA Land and Maritime, DLA Land and Maritime's agent, and the acquiring activity retain the option to review the manufacturer's facility and applicable required documentation. Offshore documentation shall be made available onshore at the option of the reviewer.

STANDARD MICROCIRCUIT DRAWING DLA LAND AND MARITIME COLUMBUS, OHIO 43218-3990	SIZE A		5962-89920
		REVISION LEVEL C	SHEET 4

TABLE I. Electrical performance characteristics.

Test	Symbol	Conditions <u>1/2/</u> -55°C ≤ T _A ≤ +125°C unless otherwise specified	Group A subgroups	Device type	Limits		Unit
					Min	Max	
POWER INPUTS SECTION							
Start-up current	I _{SU}	V _{IN} = 30 V, T _J = 25°C, START/UV pin = 2.5 V	1	01		5.5	mA
				02		6.0	
Start-up current, temperature coefficient	I _{SUTC}	<u>3/</u>	1,2,3	01		0.2	%/°C
Operating current	I _{OP}	V _{IN} = 30 V, START/UV pin = 3.5 V	1,2,3	01	5	15	mA
				02		14	
Supply OV clamp	V _{OV}	I _{IN} = 20 mA	1,2,3,	01,02	33	45	V
REFERENCE SECTION							
Reference voltage	V _{REF}	T _J = 25°C	1	01,02	4.95	5.10	V
Line regulation	V _{RLINE}	V _{IN} = 8 V to 30 V	1,2,3	01,02		15	mV
Load regulation	V _{RLOAD}	I _L = 0 mA to 20 mA	1,2,3	01		20	mV
		I _L = 0 mA to 10 mA		02		20	
Temperature stability	V _{TS}		1,2,3	01,02	4.9	5.1	V
Temperature coefficient	T _C	<u>3/</u>	1,2,3	01		±0.4	mV/°C
Short circuit current	I _{OS}	V _{REF} = 0 V, T _J = 25°C	1	01,02		-100	mA
OSCILLATOR SECTION							
Nominal frequency	f _{NOM}	T _J = 25°C	1	01,02	47	53	kHz
Voltage stability	V _{ST}	V _{IN} = 8 V to 30 V	2,3	01,02		1	%
Temperature stability	V _{TS}		2,3	01	43	58	kHz
				02	45	55	
Temperature coefficient	V _C	<u>3/</u>	1,2,3	01		±0.08	%/°C
Maximum frequency	f _{MAX}	R _T = 2 kΩ, C _T = 330 pF	1,2,3	01,02	500		kHz

See footnotes at end of table.

**STANDARD
MICROCIRCUIT DRAWING**
DLA LAND AND MARITIME
COLUMBUS, OHIO 43218-3990

SIZE
A

REVISION LEVEL
C

5962-89920
SHEET
5

TABLE I. Electrical performance characteristics – Continued.

Test	Symbol	Conditions <u>1/2/</u> -55°C ≤ T _A ≤ +125°C unless otherwise specified	Group A subgroups	Device type	Limits		Unit
					Min	Max	
RAMP GENERATOR SECTION							
Ramp current, minimum	I _{RMIN}	I _{SENSE} = -10 μA	1,2,3	01,02		-14	μA
Ramp current, maximum	I _{RMAX}	I _{SENSE} = 1.0 mA	1,2,3	01,02	-0.9		mA
Ramp valley	V _{RV}		1,2,3	01	0.3	0.7	V
				02	0.3	0.6	
Ramp peak	V _{PK}	Clamping level	1,2,3	01,02	3.9	4.5	V
ERROR AMPLIFIER SECTION							
Input offset voltage	V _{OS}	V _{CM} = 5.0 V	1,2,3	01,02		5	mV
Input bias current	I _{IB}		1,2,3	01,02		2	μA
Input offset current	I _{OS}		1,2,3	01,02		0.5	μA
Open loop gain	LG	ΔV _O = 1 V to 3 V	1,2,3	01,02	60		dB
Output swing	OS	Maximum output ≤ Ramp peak – 100 mV, minimum total range	1,2,3	01,02	0.3	3.5	V
Common mode rejection ratio	CMRR	V _{CM} = 1.5 V to 5.5 V	1,2,3	01,02	70		dB
Power supply rejection ratio	PSRR	V _{IN} = 8 V to 30 V	1,2,3	01,02	70		dB
Short circuit current	I _{OSE}	V _{COMP} = 0 V	1,2,3	01,02		-10	mA
Gain bandwidth	A _{BW}	A _{VOL} = 0 dB, <u>3/</u> T _J = 25°C	1	01,02	1		MHz
PWM SECTION							
Continuous duty cycle range (other than zero)	RDCR	Minimum total <u>3/</u> continuous range, Ramp section < 4.2 V	1,2,3	01	5	95	%
				02	4	95	
50 % duty cycle clamp	CDC	R _{SENSE} to V _{REF} = 10 kΩ	1,2,3	02	42	52	%

See footnotes at end of table.

**STANDARD
MICROCIRCUIT DRAWING**
DLA LAND AND MARITIME
COLUMBUS, OHIO 43218-3990

SIZE
A

5962-89920

REVISION LEVEL
C

SHEET
6

TABLE I. Electrical performance characteristics – Continued.

Test	Symbol	Conditions <u>1/2/</u> -55°C ≤ T _A ≤ +125°C unless otherwise specified	Group A subgroups	Device type	Limits		Unit
					Min	Max	
PWM SECTION – continued.							
Output saturation 1	S _O	I _{OUT} = 20 mA	1,2,3	01,02		0.4	V
Output saturation 2	S _O	I _{OUT} = 200 mA	1,2,3	01,02		2.2	V
Output leakage current	I _{OL}	V _{OUT} = 40 V	1,2,3	01,02		10	μA
Comparator delay	CD	R _T /C _T pin, RAMP pin, <u>3/</u> V _{IN} SENSE pin, SLOW-START pin, PWM OUTPUT pin, R _L = 1 kΩ, T _J = 25°C	1,2,3	01,02		500	Ns
SEQUENCING FUNCTIONS SECTION							
Comparator threshold (other than zero)	C _{TH}	START/UV pin, STOP pin, OV SENSE pin, RESET pin	1,2,3	01	2.8	3.2	V
		START/UV pin, OV SENSE pin, RESET pin		02	2.8	3.2	
Input bias current	I _{IB}	OV SENSE pin, STOP pin, RESET pin = 0 V	1,2,3	01		-3.0	μA
		OV SENSE pin, RESET pin = 0 V		02		-4.0	
Input leakage current	I _{IL}	V _{IN} = 20 V	1,2,3	01		10	μA
		OV SENSE pin, RESET pin = 10 V		02		2.0	
START/UV hysteresis current	I _{HS/V}	START/UV pin = 2.5 V, T _J = 25°C	1	01	180	220	μA
				02	170	220	
Driver bias saturation voltage (V _{IN} – V _{OH})	S _{DB}	I _B = -50 mA	1,2,3	01,02		3	V
External STOP threshold	T _{ES}	STOP pin	1,2,3	02	0.8	2.4	V
Error latch activate current	I _{ELA}	STOP pin = 0 V, OV SENSE pin > 3 V	1,2,3	02		-200	μA

See footnotes at end of table.

STANDARD MICROCIRCUIT DRAWING DLA LAND AND MARITIME COLUMBUS, OHIO 43218-3990	SIZE A		5962-89920
		REVISION LEVEL C	SHEET 7

TABLE I. Electrical performance characteristics – Continued.

Test	Symbol	Conditions <u>1/ 2/</u> -55°C ≤ T _A ≤ +125°C unless otherwise specified	Group A subgroups	Device type	Limits		Unit
					Min	Max	
SEQUENCING FUNCTIONS SECTION – continued.							
Driver bias leakage current	I _{DBL}	V _B = 0 V	1,2,3	01,02		-10	μA
SLOW-START saturation voltage	V _{SSS}	I _S = 2 mA	1,2,3	01		0.5	V
		I _S = 10 mA		02		0.5	
SLOW-START leakage current	I _{SSL}	V _S = 4.5 V	1,2,3	01,02		2.0	μA
CURRENT CONTROL SECTION							
Current limit offset voltage	V _{IO} L		1,2,3	01,02		5	mV
Current shutdown offset voltage	V _{ISO}		1,2,3	01,02	370	430	mV
Input bias current	I _{IB}	CURRENT SENSE pin = 0 V	1,2,3	01,02		-5	μA
Common mode range	CMR	<u>3/</u>	1,2,3	01,02	-0.4	3.0	V
Current limit delay <u>3/</u>	C _{LD}	CURRENT SENSE pin, <u>4/</u> SLOW START pin, R _T /C _T pin, RAMP pin, V _{IN} SENSE pin, PWM OUTPUT pin, R _L = 1 kΩ, T _A = 25°C	1	01,02		400	Ns

1/ C_R is connected between the RAMP pin and the GND pin. C_T is connected between the R_T/C_T pin and the GND pin. R_T is connected between the 5.0 V REF pin and the R_T/C_T pin.

2/ V_{IN} = 20 V, R_T = 20 kΩ, T_A = T_J, C_R = .001 mfd, C_T = .001 mfd, and current limit threshold voltage = 200 mV.

3/ Guaranteed, if not tested, to the limits specified in table I herein.

4/ The load resistor (R_L) is connected from PWM OUTPUT to GND.

**STANDARD
MICROCIRCUIT DRAWING**
DLA LAND AND MARITIME
COLUMBUS, OHIO 43218-3990

SIZE
A

5962-89920

REVISION LEVEL
C

SHEET
8

Device types	01 and 02	
Case outlines	V	2
Terminal number	Terminal symbol	
1	COMPENSATION	COMPENSATION
2	START/UV	START/UV
3	OV SENSE	OV SENSE
4	STOP	STOP
5	RESET	RESET
6	CURRENT THRESHOLD	NC
7	CURRENT SENSE	CURRENT THRESHOLD
8	SLOW-START	CURRENT SENSE
9	R _T /C _T	SLOW-START
10	RAMP	R _T /C _T
11	V _{IN} SENSE	RAMP
12	PWM OUTPUT	V _{IN} SENSE
13	GND	PWM OUTPUT
14	DRIVER BIAS	GND
15	+V _{IN} SUPPLY	DRIVER BIAS
16	5.0 V REF	NC
17	INVERTING INPUT	+V _{IN} SUPPLY
18	NON-INVERTING INPUT	5.0 V REF
19	---	INVERTING INPUT
20	---	NON-INVERTING INPUT

NC = No connection

FIGURE 1. Case outline.

STANDARD MICROCIRCUIT DRAWING DLA LAND AND MARITIME COLUMBUS, OHIO 43218-3990	SIZE A		5962-89920
		REVISION LEVEL C	SHEET 9

Device type 01

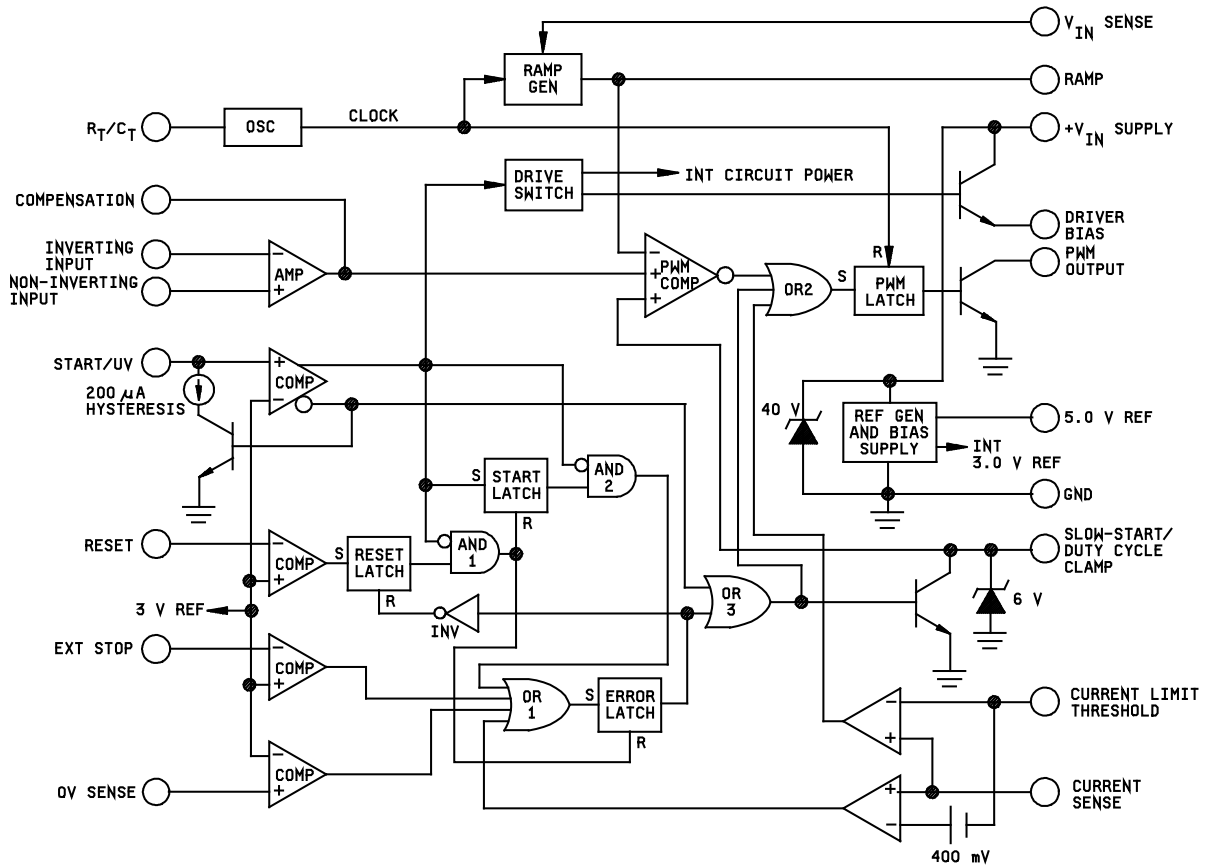

FIGURE 2. Logic diagram.

**STANDARD
MICROCIRCUIT DRAWING**
DLA LAND AND MARITIME
COLUMBUS, OHIO 43218-3990

SIZE
A

5962-89920

REVISION LEVEL
C

SHEET
10

Device type 02

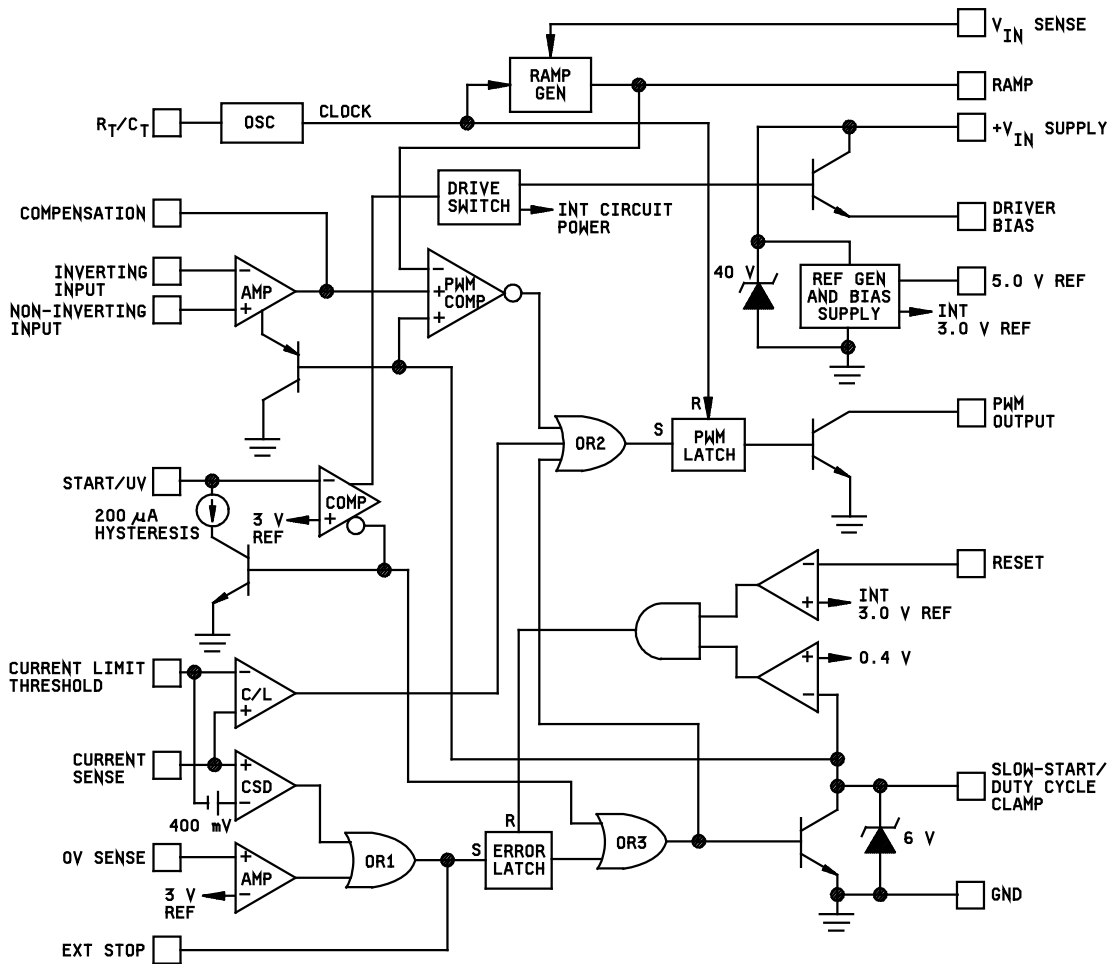

FIGURE 2. Logic diagram – Continued.

**STANDARD
MICROCIRCUIT DRAWING**
DLA LAND AND MARITIME
COLUMBUS, OHIO 43218-3990

SIZE
A

5962-89920

REVISION LEVEL
C

SHEET
11

4. VERIFICATION

4.1 Sampling and inspection. Sampling and inspection procedures shall be in accordance with MIL-PRF-38535, appendix A.

4.2 Screening. Screening shall be in accordance with method 5004 of MIL-STD-883, and shall be conducted on all devices prior to quality conformance inspection. The following additional criteria shall apply:

a. Burn-in test, method 1015 of MIL-STD-883.

(1) Test condition A, B, C, or D. The test circuit shall be maintained by the manufacturer under document revision level control and shall be made available to the preparing or acquiring activity upon request. The test circuit shall specify the inputs, outputs, biases, and power dissipation, as applicable, in accordance with the intent specified in method 1015 of MIL-STD-883.

(2) $T_A = +125^\circ\text{C}$, minimum.

b. Interim and final electrical test parameters shall be as specified in table II herein, except interim electrical parameter tests prior to burn-in are optional at the discretion of the manufacturer.

4.3 Quality conformance inspection. Quality conformance inspection shall be in accordance with method 5005 of MIL-STD-883 including groups A, B, C, and D inspections. The following additional criteria shall apply.

4.3.1 Group A inspection.

a. Tests shall be as specified in table II herein.

b. Subgroups 4, 5, 6, 7, 8, 9, 10, and 11 in table I, method 5005 of MIL-STD-883 shall be omitted.

4.3.2 Groups C and D inspections.

a. End-point electrical parameters shall be as specified in table II herein.

b. Steady-state life test conditions, method 1005 of MIL-STD-883.

(1) Test condition A, B, C, or D. The test circuit shall be maintained by the manufacturer under document revision level control and shall be made available to the preparing or acquiring activity upon request. The test circuit shall specify the inputs, outputs, biases, and power dissipation, as applicable, in accordance with the intent specified in method 1005 of MIL-STD-883.

(2) $T_A = +125^\circ\text{C}$, minimum.

(3) Test duration: 1,000 hours, except as permitted by method 1005 of MIL-STD-883.

STANDARD MICROCIRCUIT DRAWING DLA LAND AND MARITIME COLUMBUS, OHIO 43218-3990	SIZE A		5962-89920
		REVISION LEVEL C	SHEET 12

TABLE II. Electrical test requirements.

MIL-STD-883 test requirements	Subgroups (in accordance with MIL-STD-883, method 5005, table I)
Interim electrical parameters (method 5004)	1
Final electrical test parameters (method 5004)	1*,2,3
Group A test requirements (method 5005)	1,2,3
Groups C and D end-point electrical parameters (method 5005)	1,2,3

* PDA applies to subgroup 1.

5. PACKAGING

5.1 Packaging requirements. The requirements for packaging shall be in accordance with MIL-PRF-38535, appendix A.

6. NOTES

6.1 Intended use. Microcircuits conforming to this drawing are intended for use for Government microcircuit applications (original equipment), design applications, and logistics purposes.

6.2 Replaceability. Microcircuits covered by this drawing will replace the same generic device covered by a contractor-prepared specification or drawing.

6.3 Configuration control of SMD's. All proposed changes to existing SMD's will be coordinated with the users of record for the individual documents. This coordination will be accomplished using DD Form 1692, Engineering Change Proposal.

6.4 Record of users. Military and industrial users shall inform DLA Land and Maritime when a system application requires configuration control and the applicable SMD to that system. DLA Land and Maritime will maintain a record of users and this list will be used for coordination and distribution of changes to the drawings. Users of drawings covering microelectronics devices (FSC 5962) should contact DLA Land and Maritime -VA, telephone (614) 692-0544.

6.5 Comments. Comments on this drawing should be directed to DLA Land and Maritime -VA, Columbus, Ohio 43218-3990, or telephone (614) 692-0540.

6.6 Approved sources of supply. Approved sources of supply are listed in MIL-HDBK-103. The vendors listed in MIL-HDBK-103 have agreed to this drawing and a certificate of compliance (see 3.6 herein) has been submitted to and accepted by DLA Land and Maritime -VA.

STANDARD MICROCIRCUIT DRAWING DLA LAND AND MARITIME COLUMBUS, OHIO 43218-3990	SIZE A		5962-89920
		REVISION LEVEL C	SHEET 13

STANDARD MICROCIRCUIT DRAWING BULLETIN

DATE: 11-07-19

Approved sources of supply for SMD 5962-89920 are listed below for immediate acquisition information only and shall be added to MIL-HDBK-103 and QML-38535 during the next revision. MIL-HDBK-103 and QML-38535 will be revised to include the addition or deletion of sources. The vendors listed below have agreed to this drawing and a certificate of compliance has been submitted to and accepted by DLA Land and Maritime -VA. This information bulletin is superseded by the next dated revision of MIL-HDBK-103 and QML-38535. DLA Land and Maritime maintains an online database of all current sources of supply at <http://www.landandmaritime.dla.mil/Programs/Smcr/>.

Standard microcircuit drawing PIN <u>1/</u>	Vendor CAGE number	Vendor similar PIN <u>2/</u>
5962-8992001VA	3V146	UC1840J/883
5962-89920012A	3V146	UC1840L/883
5962-8992002VA	<u>3/</u>	UC1841J/883BC
5962-89920022A	<u>3/</u>	UC1841L/883BC

- 1/ The lead finish shown for each PIN representing a hermetic package is the most readily available from the manufacturer listed for that part. If the desired lead finish is not listed contact the vendor to determine its availability.
- 2/ Caution. Do not use this number for item acquisition. Items acquired to this number may not satisfy the performance requirements of this drawing.
- 3/ Not available from an approved source of supply.

Vendor CAGE
number

3V146

Vendor name
and address

Rochester Electronics
16 Malcolm Hoyt Drive
Newburyport, MA 01950

The information contained herein is disseminated for convenience only and the Government assumes no liability whatsoever for any inaccuracies in the information bulletin.