

5495A, DM7495

4-Bit Parallel Access Shift Registers

These 4-bit registers feature parallel and serial inputs, parallel outputs, mode control, and two clock inputs. The registers have three modes of operation: parallel (broadside) load, shift right (the direction Q_A toward Q_D), and shift left (the direction Q_D toward Q_A).

Parallel loading is accomplished by applying the four bits of data and taking the mode control input high. The data is loaded into the associated flip-flops and appears at the outputs after the high-to-low transition of the clock-2 input. During loading, the entry of serial data is inhibited.

Shift right is accomplished on the high-to-low transition of clock 1 when the mode control is low; shift left is accomplished on the high-to-low transition of clock 2 when the mode control is high by connecting the output of each flip-flop to the parallel input of the previous flip-flop (Q_D to input C, etc) and serial data is entered at input D. The clock input may be applied simultaneously to clock 1 and clock 2 if both modes can be clocked from the same source.

Rochester Electronics Manufactured Components

Rochester branded components are manufactured using either die/wafers purchased from the original suppliers or Rochester wafers recreated from the original IP. All recreations are done with the approval of the OCM.

Parts are tested using original factory test programs or Rochester developed test solutions to guarantee product meets or exceeds the OCM data sheet.

Quality Overview

- ISO-9001
- AS9120 certification
- Qualified Manufacturers List (QML) MIL-PRF-38535
 - Class Q Military
 - Class V Space Level
- Qualified Suppliers List of Distributors (QSLD)
 - Rochester is a critical supplier to DLA and meets all industry and DLA standards.

Rochester Electronics, LLC is committed to supplying products that satisfy customer expectations for quality and are equal to those originally supplied by industry manufacturers.

The original manufacturer's datasheet accompanying this document reflects the performance and specifications of the Rochester manufactured version of this device. Rochester Electronics guarantees the performance of its semiconductor products to the original OEM specifications. 'Typical' values are for reference purposes only. Certain minimum or maximum ratings may be based on product characterization, design, simulation, or sample testing.

5495A/DM7495 4-Bit Parallel Access Shift Registers

General Description

These 4-bit registers feature parallel and serial inputs, parallel outputs, mode control, and two clock inputs. The registers have three modes of operation.

- Parallel (broadside) load
- Shift right (the direction Q_A toward Q_D)
- Shift left (the direction Q_D toward Q_A)

Parallel loading is accomplished by applying the four bits of data and taking the mode control input high. The data is loaded into the associated flip-flops and appears at the outputs after the high-to-low transition of the clock-2 input. During loading, the entry of serial data is inhibited.

Shift right is accomplished on the high-to-low transition of clock 1 when the mode control is low; shift left is accomplished on the high-to-low transition of clock 2 when the

mode control is high by connecting the output of each flip-flop to the parallel input of the previous flip-flop (Q_D to input C, etc.) and serial data is entered at input D. The clock input may be applied simultaneously to clock 1 and clock 2 if both modes can be clocked from the same source.

Changes at the mode control input should normally be made while both clock inputs are low; however, conditions described in the last three lines of the truth table will also ensure that register contents are protected.

Features

- Typical maximum clock frequency 36 MHz
- Typical power dissipation 250 mW

Connection Diagram

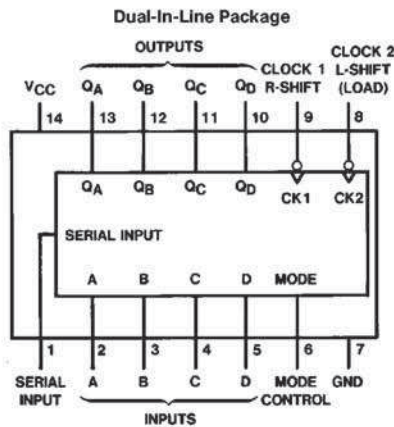

Order Number 5495ADMQB, 5495AFMQB or DM7495N
See NS Package Number J14A, N14A or W14B

TL/F/6534-1

Absolute Maximum Ratings (Note)

If Military/Aerospace specified devices are required, please contact the National Semiconductor Sales Office/Distributors for availability and specifications.

Supply Voltage	7V
Input Voltage	5.5V
Operating Free Air Temperature Range	
54A	-55°C to +125°C
DM74	0°C to +70°C
Storage Temperature Range	-65°C to +150°C

Note: The "Absolute Maximum Ratings" are those values beyond which the safety of the device cannot be guaranteed. The device should not be operated at these limits. The parametric values defined in the "Electrical Characteristics" table are not guaranteed at the absolute maximum ratings. The "Recommended Operating Conditions" table will define the conditions for actual device operation.

Recommended Operating Conditions

Symbol	Parameter	5495A			DM7495			Units
		Min	Nom	Max	Min	Nom	Max	
V _{CC}	Supply Voltage	4.5	5	5.5	4.75	5	5.25	V
V _{IH}	High Level Input Voltage	2			2			V
V _{IL}	Low Level Input Voltage			0.8			0.8	V
I _{OH}	High Level Output Current			-0.8			-0.8	mA
I _{OL}	Low Level Output Current			16			16	mA
f _{CLK}	Clock Frequency (Note 4)	0		25	0		25	MHz
t _W	Clock Pulse Width (Note 4)	15	11		15			ns
t _{SU}	Data Setup Time (Note 4)	20	10		20	10		ns
t _{EN}	Time to Enable Clock (Note 4)	Clock 1	20		20			ns
		Clock 2	15		15			
t _H	Data Hold Time (Note 4)	0	-10		0	-10		ns
t _{IN}	Time to Inhibit Clock 1 or Clock 2 (Note 4)	10			10			ns
T _A	Free Air Operating Temperature	-55		125	0		70	°C

Electrical Characteristics over recommended operating free air temperature range (unless otherwise noted)

Symbol	Parameter	Conditions	Min	Typ (Note 1)	Max	Units
V _I	Input Clamp Voltage	V _{CC} = Min, I _I = -12 mA			-1.5	V
V _{OH}	High Level Output Voltage	V _{CC} = Min, I _{OH} = Max V _{IL} = Max, V _{IH} = Min	2.4	3.4		V
V _{OL}	Low Level Output Voltage	V _{CC} = Min, I _{OL} = Max V _{IH} = Min, V _{IL} = Max		0.2	0.4	V
I _I	Input Current @ Max Input Voltage	V _{CC} = Max, V _I = 5.5V			1	mA
I _{IH}	High Level Input Current	V _{CC} = Max V _I = 2.4V	Mode		80	μA
			Others		40	
I _{IL}	Low Level Input Current	V _{CC} = Max V _I = 0.4V	Mode		-3.2	mA
			Others		-1.6	
I _{OS}	Short Circuit Output Current	V _{CC} = Max (Note 2)	DM54	-18	-57	mA
			DM74	-18	-57	
I _{CC}	Supply Current	V _{CC} = Max (Note 3)		50	75	mA

Note 1: All typicals are at V_{CC} = 5V, T_A = 25°C.

Note 2: Not more than one output should be shorted at a time.

Note 3: I_{CC} is measured with all outputs and serial input open; A, B, C, and D inputs grounded; Mode Control at 4.5V; and a momentary 3V, then ground, applied to both clock inputs.

Note 4: T_A = 25°C and V_{CC} = 5V.

Switching Characteristics at $V_{CC} = 5V$ and $T_A = 25^\circ C$ (See Section 1 for Test Waveforms and Output Load)

Symbol	Parameter	From (Input) To (Output)	$R_L = 400\Omega, C_L = 15\text{ pF}$		Units
			Min	Max	
f_{MAX}	Maximum Clock Frequency		25		MHz
t_{PHL}	Propagation Delay Time High to Low Level Output	Clock to Output		35	ns
t_{PLH}	Propagation Delay Time Low to High Level Output	Clock to Output		35	ns

Function Table

Mode Control	Inputs							Outputs			
	Clocks		Serial	Parallel				Q_A	Q_B	Q_C	Q_D
	2(L)	1(R)		A	B	C	D				
H	H	X	X	X	X	X	X	Q_{A0}	Q_{B0}	Q_{C0}	Q_{D0}
H	↓	X	X	a	b	c	d	a	b	c	d
H	↓	X	X	$Q_{B\uparrow}$	$Q_{C\uparrow}$	$Q_{D\uparrow}$	d	Q_{Bn}	Q_{Cn}	Q_{Dn}	d
L	L	H	X	X	X	X	X	Q_{A0}	Q_{B0}	Q_{C0}	Q_{D0}
L	X	↓	H	X	X	X	X	H	Q_{An}	Q_{Bn}	Q_{Cn}
L	X	↓	L	X	X	X	X	L	Q_{An}	Q_{Bn}	Q_{Cn}
↑	L	L	X	X	X	X	X	Q_{A0}	Q_{B0}	Q_{C0}	Q_{D0}
↓	L	L	X	X	X	X	X	Q_{A0}	Q_{B0}	Q_{C0}	Q_{D0}
↓	L	H	X	X	X	X	X	Q_{A0}	Q_{B0}	Q_{C0}	Q_{D0}
↑	H	L	X	X	X	X	X	Q_{A0}	Q_{B0}	Q_{C0}	Q_{D0}
↑	H	H	X	X	X	X	X	Q_{A0}	Q_{B0}	Q_{C0}	Q_{D0}

† Shifting left requires external connection of Q_B to A, Q_C to B, Q_D to C. Serial data is entered at input D.

H = High Level (Steady State), L = Low Level (Steady State), X = Don't Care (Any input, including transitions)

↓ = Transition from high to low level, ↑ = Transition from low to high level

a, b, c, d = The level of steady, state input at inputs A, B, C, or D, respectively.

$Q_{A0}, Q_{B0}, Q_{C0}, Q_{D0}$ = The level of Q_A, Q_B, Q_C, Q_D , respectively, before the indicated steady state input conditions were established.

$Q_{An}, Q_{Bn}, Q_{Cn}, Q_{Dn}$ = The level of Q_A, Q_B, Q_C, Q_D , respectively, before the most recent ↓ transition of the clock.

Logic Diagram

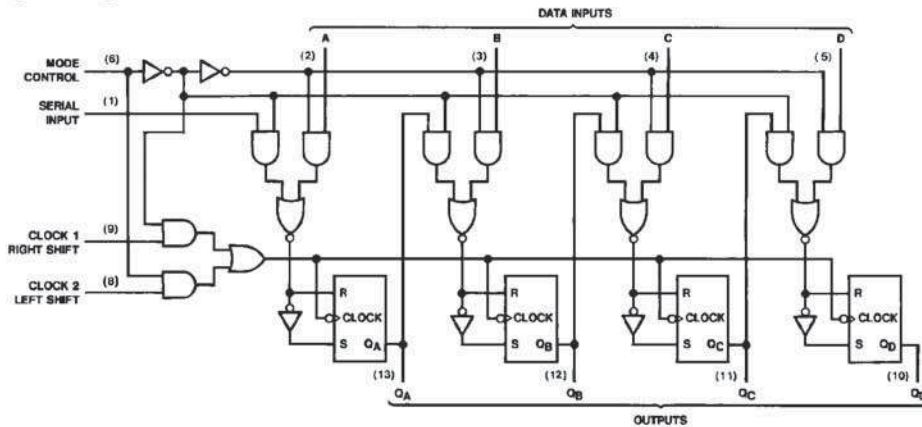

TL/F/6534-2

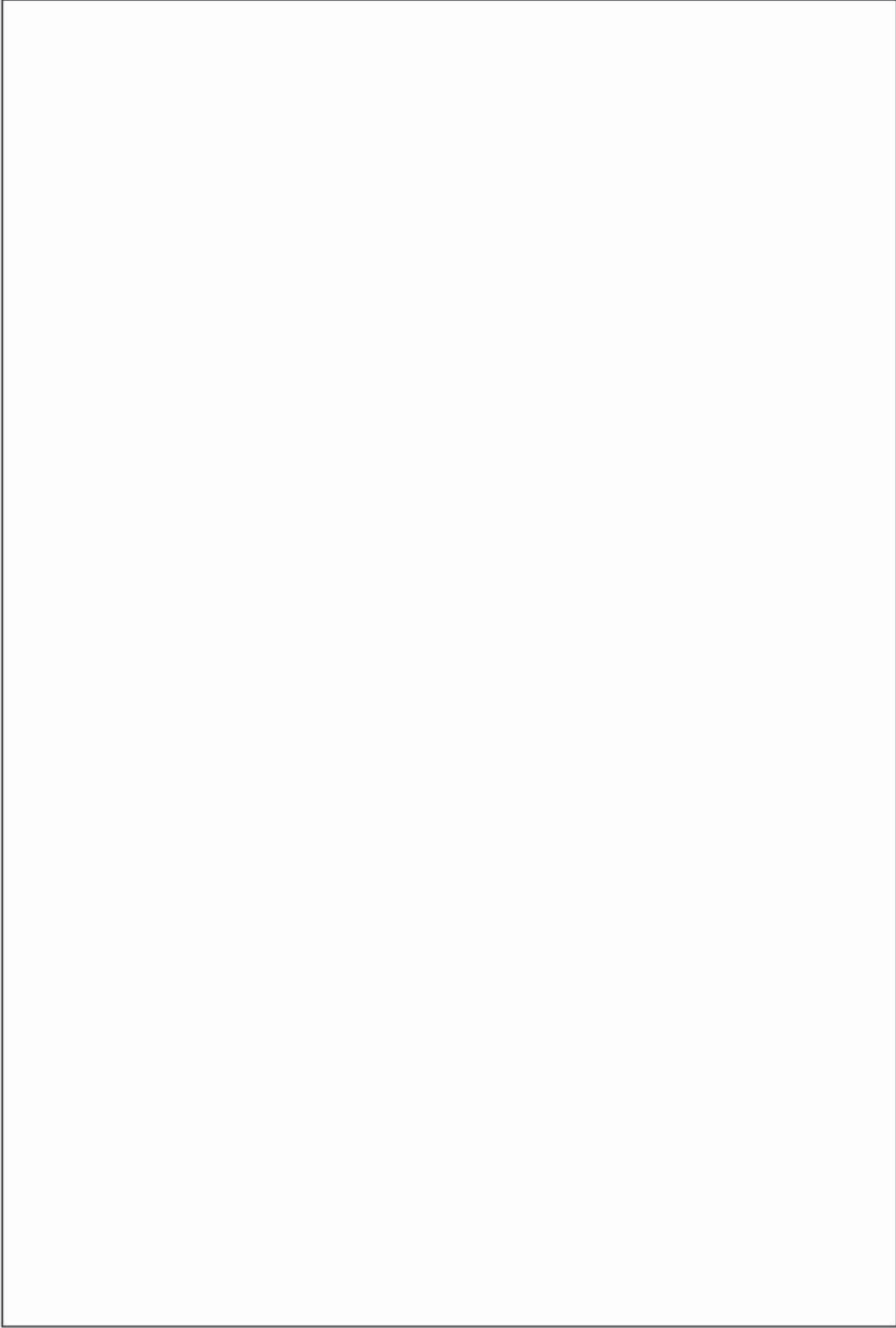

Physical Dimensions inches (millimeters)

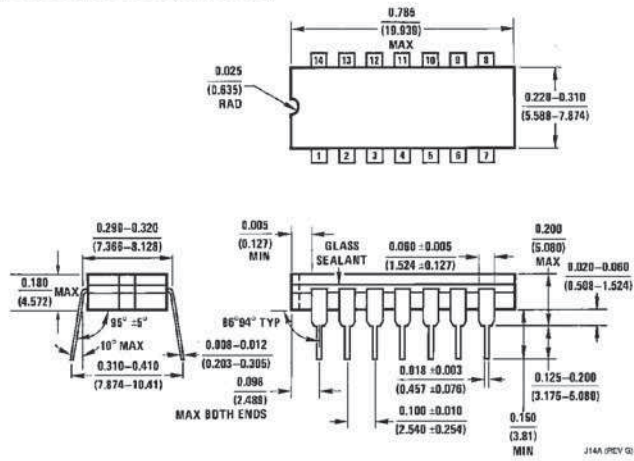

14-Lead Ceramic Dual-In-Line Package (J)
Order Number 5495ADMQB
NS Package Number J14A

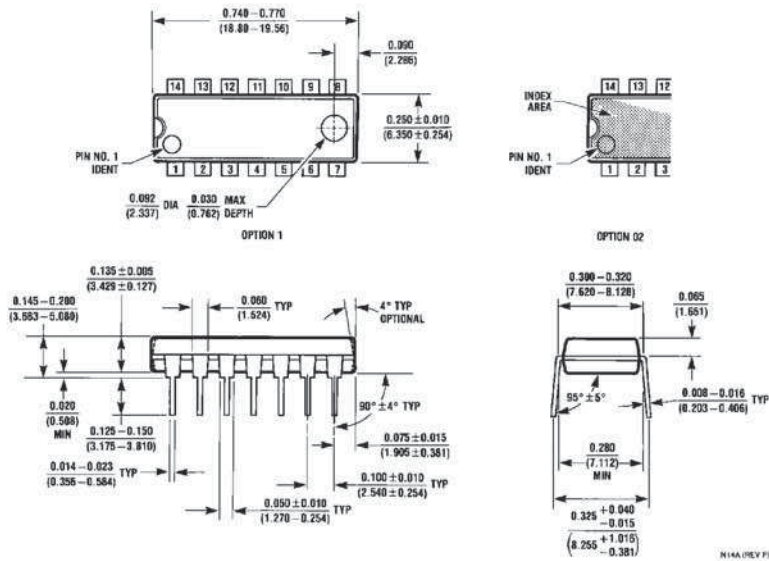

14-Lead Molded Dual-In-Line Package (N)
Order Number DM7495N
NS Package Number N14A

Physical Dimensions inches (millimeters)

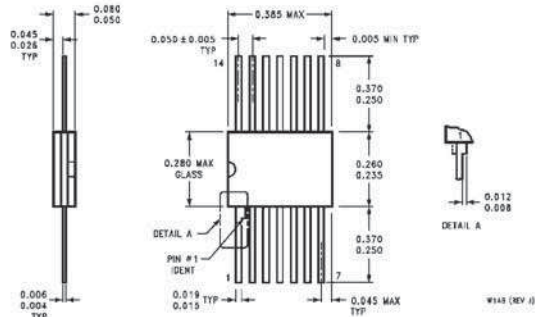

14-Lead Ceramic Flat Package (W)
Order Number 5495AFMQB
NS Package Number W14B

LIFE SUPPORT POLICY

NATIONAL'S PRODUCTS ARE NOT AUTHORIZED FOR USE AS CRITICAL COMPONENTS IN LIFE SUPPORT DEVICES OR SYSTEMS WITHOUT THE EXPRESS WRITTEN APPROVAL OF THE PRESIDENT OF NATIONAL SEMICONDUCTOR CORPORATION. As used herein:

1. Life support devices or systems are devices or systems which, (a) are intended for surgical implant into the body, or (b) support or sustain life, and whose failure to perform, when properly used in accordance with instructions for use provided in the labeling, can be reasonably expected to result in a significant injury to the user.
2. A critical component is any component of a life support device or system whose failure to perform can be reasonably expected to cause the failure of the life support device or system, or to affect its safety or effectiveness.



National Semiconductor Corporation
 1111 West Bardin Road
 Arlington, TX 76017
 Tel: 1(800) 272-9959
 Fax: 1(800) 737-7018

National Semiconductor Europe
 Fax: (+49) 0-180-530 85 86
 Email: cnjwge@tevm2.nsc.com
 Deutsch Tel: (+49) 0-180-530 85 85
 English Tel: (+49) 0-180-532 78 32
 Français Tel: (+49) 0-180-532 93 58
 Italiano Tel: (+49) 0-180-534 16 80

National Semiconductor Hong Kong Ltd.
 13th Floor, Straight Block,
 Ocean Centre, 5 Canton Rd.
 Tsimshatsui, Kowloon
 Hong Kong
 Tel: (852) 2737-1600
 Fax: (852) 2736-9960

National Semiconductor Japan Ltd.
 Tel: 81-043-299-2309
 Fax: 81-043-299-2408

National does not assume any responsibility for use of any circuitry described, no circuit patent licenses are implied and National reserves the right at any time without notice to change said circuitry and specifications.