

54LS168 Synchronous Bi-Directional

BCD Decade Counter

The 54LS168 is a fully synchronous 4-state up/down counter featuring a preset capability for programmable operation, carry lookahead for easy cascading and a U/\bar{D} input to control the direction of counting. It counts in the BCD (8421) sequence and all state changes, whether in counting or parallel loading, are initiated by the LOW-to-HIGH transition of the clock.

Rochester Electronics Manufactured Components

Rochester branded components are manufactured using either die/wafers purchased from the original suppliers or Rochester wafers recreated from the original IP. All recreations are done with the approval of the OCM.

Parts are tested using original factory test programs or Rochester developed test solutions to guarantee product meets or exceeds the OCM data sheet.

Quality Overview

- ISO-9001
- AS9120 certification
- Qualified Manufacturers List (QML) MIL-PRF-38535
 - Class Q Military
 - Class V Space Level
- Qualified Suppliers List of Distributors (QSLD)
 - Rochester is a critical supplier to DLA and meets all industry and DLA standards.

Rochester Electronics, LLC is committed to supplying products that satisfy customer expectations for quality and are equal to those originally supplied by industry manufacturers.

The original manufacturer's datasheet accompanying this document reflects the performance and specifications of the Rochester manufactured version of this device. Rochester Electronics guarantees the performance of its semiconductor products to the original OEM specifications. 'Typical' values are for reference purposes only. Certain minimum or maximum ratings may be based on product characterization, design, simulation, or sample testing.



54LS168 Synchronous Bi-Directional BCD Decade Counter

General Description

The 54LS168 is a fully synchronous 4-state up/down counter featuring a preset capability for programmable operation, carry lookahead for easy cascading and a U/ \bar{D} input to control the direction of counting. It counts in the BCD (8421) sequence and all state changes, whether in counting or parallel loading, are initiated by the LOW-to-HIGH transition of the clock.

Connection Diagram

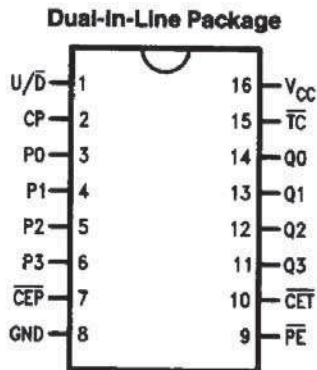

TL/F/10207-1

Order Number 54LS168DMQB,
54LS168FMQB or 54LS168LMQB
See NS Package Number
E20A, J16A or W16A

Logic Symbol

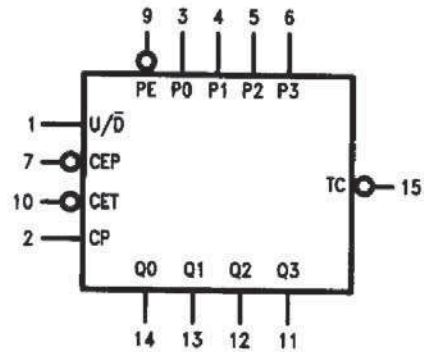

V_{CC} = Pin 16
GND = Pin 8

TL/F/10207-2

Pin Names	Description
\overline{CEP}	Count Enable Parallel Input (Active LOW)
\overline{CET}	Count Enable Trickle Input (Active LOW)
CP	Clock Pulse Input (Active Rising Edge)
P0-P3	Parallel Data Inputs
PE	Parallel Enable Input (Active LOW)
U/ \bar{D}	Up-Down Count Control Input
Q0-Q3	Flip-Flop Outputs
\overline{TC}	Terminal Count Output (Active LOW)

Absolute Maximum Ratings (Note)

If Military/Aerospace specified devices are required, please contact the National Semiconductor Sales Office/Distributors for availability and specifications.

Supply Voltage	7V
Input Voltage	5.5V
Operating Free Air Temperature Range	
54LS	-55°C to +125°C
Storage Temperature Range	-65°C to +150°C

Note: The "Absolute Maximum Ratings" are those values beyond which the safety of the device cannot be guaranteed. The device should not be operated at these limits. The parametric values defined in the "Electrical Characteristics" table are not guaranteed at the absolute maximum ratings. The "Recommended Operating Conditions" table will define the conditions for actual device operation.

Recommended Operating Conditions

Symbol	Parameter	54LS168			Units
		Min	Nom	Max	
V _{CC}	Supply Voltage	4.5	5	5.5	V
V _{IH}	High Level Input Voltage	2			V
V _{IL}	Low Level Input Voltage			0.7	V
I _{OH}	High Level Output Current			-0.4	mA
I _{OL}	Low Level Output Current			4	mA
T _A	Free Air Operating Temperature	-55		125	°C
t _s (H) t _s (L)	Setup Time HIGH or LOW P _n , \overline{CEP} or \overline{CET} to CP	15 15			ns
t _h (H) t _h (L)	Hold Time HIGH or LOW P _n , \overline{CEP} or \overline{CET} to CP	5 5			ns
t _s (H) t _s (L)	Setup Time HIGH or LOW PE to CP	20 20			ns
t _h (H) t _h (L)	Hold Time HIGH or LOW \overline{PE} to CP	0 0			ns
t _s (H) t _s (L)	Setup Time HIGH or LOW U/ \overline{D} to CP	25 25			ns
t _h (H) t _h (L)	Hold Time HIGH or LOW U/ \overline{D} to CP	0 0			ns
t _w (H) t _w (L)	CP Pulse Width HIGH or LOW	20 20			ns

Electrical Characteristics

over recommended operating free air temperature range (unless otherwise noted)

Symbol	Parameter	Conditions	Min	Typ (Note 1)	Max	Units
V_I	Input Clamp Voltage	$V_{CC} = \text{Min}, I_I = -18 \text{ mA}$			-1.5	V
V_{OH}	High Level Output Voltage	$V_{CC} = \text{Min}, I_{OH} = \text{Max}, V_{IL} = \text{Max}, V_{IH} = \text{Min}$	2.5			V
V_{OL}	Low Level Output Voltage	$V_{CC} = \text{Min}, I_{OL} = \text{Max}, V_{IH} = \text{Min}, V_{IL} = \text{Max}$			0.4	V
I_I	Input Current @ Max Input Voltage	$V_{CC} = \text{Max}, V_I = 10.0\text{V}$			0.1	mA
I_{IH}	High Level Input Current	$V_{CC} = \text{Max}, V_I = 2.7\text{V}$	Inputs		20	μA
			$\overline{\text{CET}}$		40	
I_{IL}	Low Level Input Current	$V_{CC} = \text{Max}, V_I = 0.5\text{V}$	Data	-0.5	-400	μA
			CP, PE, U/D, $\overline{\text{CEP}}$	-30	-400	
			$\overline{\text{CET}}$	-60	-800	
I_{OS}	Short Circuit Output Current	$V_{CC} = \text{Max}$ (Note 2)	-20		-100	mA
I_{CC}	Supply Current	$V_{CC} = \text{Max}$ (Note 3)			34	mA

Note 1: All typicals are at $V_{CC} = 5\text{V}, T_A = 25^\circ\text{C}$.

Note 2: Not more than one output should be shorted at a time, and the duration should not exceed one second.

Note 3: I_{CC} is measured with all outputs open and all inputs grounded.

Switching Characteristics

$V_{CC} = +5.0\text{V}, T_A = +25^\circ\text{C}$ (See Section 1 for test waveforms and output load)

Symbol	Parameter	54LS168		Units
		$C_L = 15 \text{ pF}$		
		Min	Max	
f_{Max}	Maximum Clock Frequency	25		MHz
t_{PLH} t_{PHL}	Propagation Delay CP to Q_n		20 20	ns
t_{PLH} t_{PHL}	Propagation Delay CP to $\overline{\text{TC}}$		30 30	ns
t_{PLH} t_{PHL}	Propagation Delay $\overline{\text{CET}}$ to $\overline{\text{TC}}$		15 20	ns
t_{PLH} t_{PHL}	Propagation Delay U/D to $\overline{\text{TC}}$		25 25	ns

Functional Description

The 'LS168 uses edge-triggered D-type flip-flops and has no constraints on changing the control or data input signals in either state of the Clock. The only requirement is that the various inputs attain the desired state at least a setup time before the rising edge of the clock and remain valid for the recommended hold time thereafter. The parallel load operation takes precedence over the other operations, as indicated in the Mode Select Table. When \overline{PE} is LOW, the data on the P0-P3 inputs enters the flip-flops on the next rising edge of the Clock. In order for counting to occur, both \overline{CEP} and \overline{CET} must be LOW and \overline{PE} must be HIGH. The U/D input then determines the direction of counting. The Terminal Count (\overline{TC}) output is normally HIGH and goes LOW, provided that \overline{CET} is LOW, when a counter reaches zero in the COUNT DOWN mode or reaches 9 in the COUNT UP mode. The \overline{TC} output state is not a function of the Count Enable Parallel (\overline{CEP}) input level. The \overline{TC} output of the 'LS168 decade counter can also be LOW in the illegal states 11, 13 and 15, which can occur when power is turned on or via parallel loading. If an illegal state occurs, the 'LS168 will return to the legitimate sequence within two counts. Since the \overline{TC} signal is derived by decoding the flip-flop states, there exists the possibility of decoding spikes on \overline{TC} . For this reason the use of \overline{TC} as a clock signal is not recommended (see logic equation below).

1. Count Enable = $\overline{CEP} \cdot \overline{CET} \cdot \overline{PE}$
2. Up: $\overline{TC} = Q_0 \cdot Q_3 \cdot (U/D) \cdot \overline{CET}$
3. Down: $\overline{TC} = Q_0 \cdot Q_1 \cdot Q_2 \cdot Q_3 \cdot (U/D) \cdot \overline{CET}$

'LS168 Mode Select Table

PE	CEP	CET	U/D	Action on Rising Clock Edge
L	X	X	X	Load ($P_n \rightarrow Q_n$)
H	L	L	H	Count Up (Increment)
H	L	L	L	Count Down (Decrement)
H	H	X	X	No Change (Hold)
H	X	H	X	No Change (Hold)

H = HIGH Voltage Level
 L = LOW Voltage Level
 X = Immaterial

State Diagram

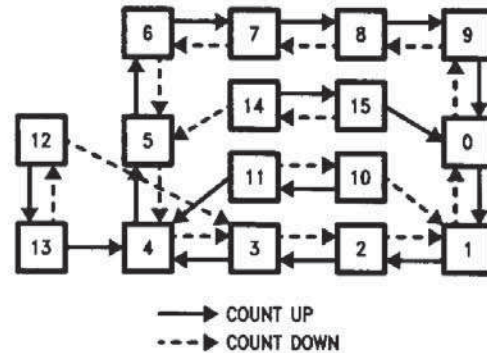

TL/F/10207-3

Logic Diagram

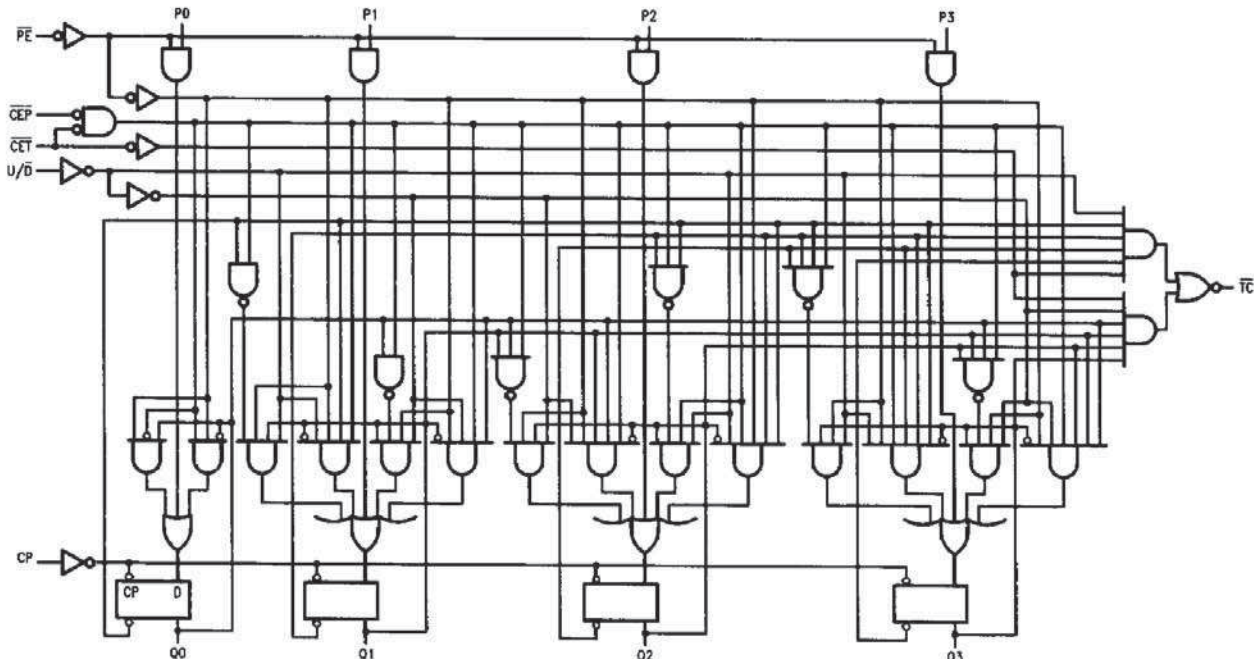

TL/F/10207-4