

## 74F403A

### *First-In First-Out (FIFO) Buffer Memory*

The 74F403A is an expandable fall-through type high-speed First-In First-Out (FIFO) Buffer Memory optimized for high-speed disk or tape controllers and communication buffer applications. It is organized as 16-words by 4-bits and may be expanded to any number of words or any number of bits in multiples of four. Data may be entered or extracted asynchronously in serial or parallel, allowing economical implementation of buffer memories.

---

#### **Rochester Electronics Manufactured Components**

Rochester branded components are manufactured using either die/wafers purchased from the original suppliers or Rochester wafers recreated from the original IP. All recreations are done with the approval of the OCM.

Parts are tested using original factory test programs or Rochester developed test solutions to guarantee product meets or exceeds the OCM data sheet.

#### **Quality Overview**

- ISO-9001
- AS9120 certification
- Qualified Manufacturers List (QML) MIL-PRF-38535
  - Class Q Military
  - Class V Space Level
- Qualified Suppliers List of Distributors (QSLD)
  - Rochester is a critical supplier to DLA and meets all industry and DLA standards.

Rochester Electronics, LLC is committed to supplying products that satisfy customer expectations for quality and are equal to those originally supplied by industry manufacturers.

---

*The original manufacturer's datasheet accompanying this document reflects the performance and specifications of the Rochester manufactured version of this device. Rochester Electronics guarantees the performance of its semiconductor products to the original OEM specifications. 'Typical' values are for reference purposes only. Certain minimum or maximum ratings may be based on product characterization, design, simulation, or sample testing.*

## 74F403A First-In First-Out (FIFO) Buffer Memory

### General Description

The 74F403A is an expandable fall-through type high-speed First-In First-Out (FIFO) Buffer Memory optimized for high-speed disk or tape controllers and communication buffer applications. It is organized as 16-words by 4-bits and may be expanded to any number of words or any number of bits in multiples of four. Data may be entered or extracted asynchronously in serial or parallel, allowing economical implementation of buffer memories.

The 74F403A has 3-STATE outputs which provide added versatility and is fully compatible with all TTL families.

### Features

- Serial or parallel input
- Serial or parallel output
- Expandable without external logic
- 3-STATE outputs
- Fully compatible with all TTL families
- Slim 24-pin package
- 9403A replacement
- Guaranteed 4000V minimum ESD protection

### Ordering Code:

Order Number	Package Number	Package Description
74F403ASPC	N24C	24-Lead Plastic Dual-In-Line Package (PDIP), JEDEC MS-100, 0.300 Wide

Devices also available in Tape and Reel. Specify by appending the suffix letter "X" to the ordering code.

### Connection Diagram

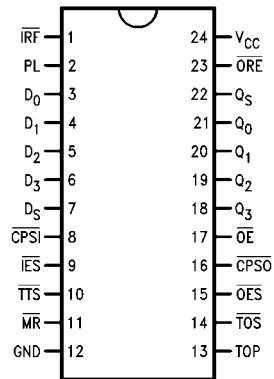

### Logic Symbol

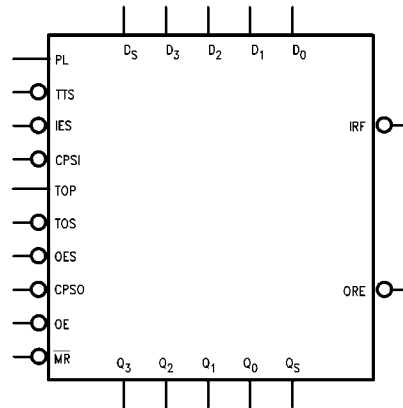

## Unit Loading/Fan Out:

See Section 2 for U.L. definitions

Pin Names	Description	U.L.	
		HIGH/LOW	Input $I_{IH}/I_{IL}$ Output $I_{OH}/I_{OL}$
$D_0 - D_3$	Parallel Data Inputs	1.0/0.667	20 $\mu$ A/400 $\mu$ A
$D_S$	Serial Data Input	1.0/0.667	20 $\mu$ A/400 $\mu$ A
PL	Parallel Load Input	1.0/0.667	20 $\mu$ A/400 $\mu$ A
$\overline{CPSI}$	Serial Input Clock	1.0/0.667	20 $\mu$ A/400 $\mu$ A
$\overline{IES}$	Serial Input Enable	1.0/0.667	20 $\mu$ A/400 $\mu$ A
$\overline{TTS}$	Transfer to Stack Input	1.0/0.667	20 $\mu$ A/400 $\mu$ A
$\overline{OES}$	Serial Output Enable	1.0/0.667	20 $\mu$ A/400 $\mu$ A
$\overline{TOS}$	Transfer Out Serial	1.0/0.667	20 $\mu$ A/400 $\mu$ A
TOP	Transfer Out Parallel	1.0/0.667	20 $\mu$ A/400 $\mu$ A
$\overline{MR}$	Master Reset	1.0/0.667	20 $\mu$ A/400 $\mu$ A
$\overline{OE}$	Output Enable	1.0/0.667	20 $\mu$ A/400 $\mu$ A
$\overline{CPSO}$	Serial Output Clock	1.0/0.667	20 $\mu$ A/400 $\mu$ A
$Q_0 - Q_3$	Parallel Data Outputs	285/26.7	5.7 mA/16 mA
$Q_S$	Serial Data Output	285/26.7	5.7 mA/16 mA
$\overline{IRF}$	Input Register Full	20/13.3	-400 $\mu$ A/8 mA
$\overline{ORE}$	Output Register Empty	20/13.3	-400 $\mu$ A/8 mA

## Functional Description

As shown in the Block Diagram the 74F403A consists of three sections:

1. An Input register with parallel and serial data inputs as well as control inputs and outputs for input handshaking and expansion.
2. A 4-bit wide, 14-word deep fall-through stack with self-contained control logic.
3. An Output Register with parallel and serial data outputs as well as control inputs and outputs for output handshaking and expansion.

Since these three sections operate asynchronously and almost independently, they will be described separately below.

### INPUT REGISTER (DATA ENTRY)

The Input Register can receive data in either bit-serial or in 4-bit parallel form. It stores this data until it is sent to the fall-through stack and generates the necessary status and control signals.

Figure 1 is a conceptual logic diagram of the input section. As described later, this 5-bit register is initialized by setting

## Block Diagram

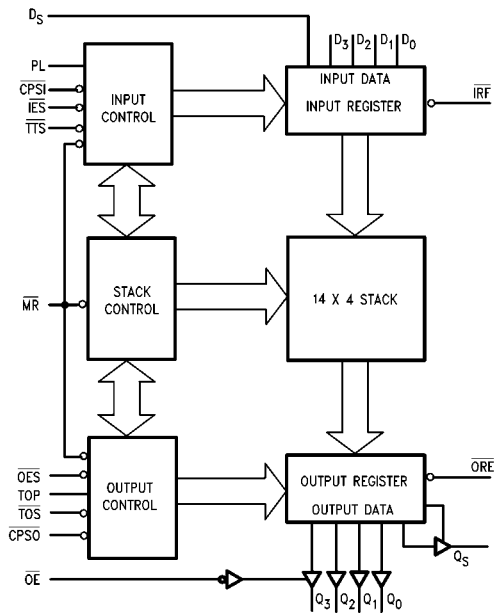

the  $F_3$  flip-flop and resetting the other flip-flops. The  $\overline{Q}$  output of the last flip-flop (FC) is brought out as the "Input Register Full" output ( $\overline{IRF}$ ). After initialization this output is HIGH.

**Parallel Entry—** A HIGH on the PL input loads the  $D_0$ - $D_3$  inputs into the  $F_0$ - $F_3$  flip-flops and sets the FC flip-flop. This forces the  $\overline{IRF}$  output LOW indicating that the input register is full. During parallel entry, the  $\overline{CPSI}$  input must be LOW. If parallel expansion is not being implemented,  $\overline{IES}$  must be LOW to establish row mastership (see Expansion section).

**Serial Entry—** Data on the  $D_S$  input is serially entered into the  $F_3, F_2, F_1, F_0, FC$  shift register on each HIGH-to-LOW transition of the  $\overline{CPSI}$  clock input, provided  $\overline{IES}$  and PL are LOW.

After the fourth clock transition, the four data bits are located in the four flip-flops,  $F_0$ - $F_3$ . The FC flip-flop is set, forcing the  $\overline{IRF}$  output LOW and internally inhibiting  $\overline{CPSI}$  clock pulses from affecting the register, Figure 2 illustrates the final positions in a 74F403A resulting from a 64-bit serial bit train.  $B_0$  is the first bit,  $B_{63}$  the last bit.

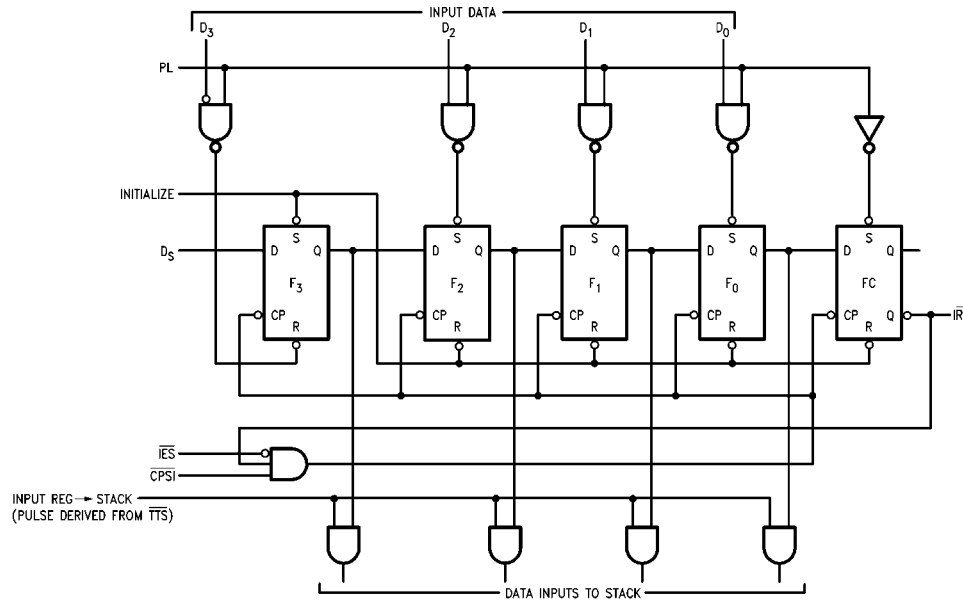

FIGURE 1. Conceptual Input Section

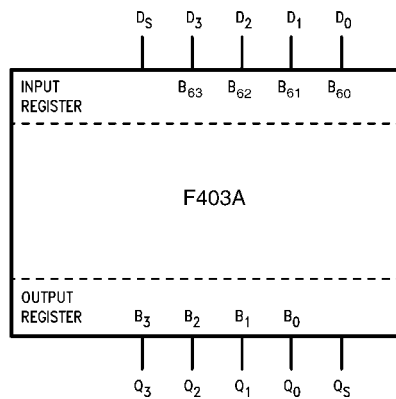

FIGURE 2. Final Positions in a 74F403A Resulting from a 64-Bit Serial Train

**Transfer to the Stack**— The outputs of Flip-Flops  $F_0$ - $F_3$  feed the stack. A LOW level on the  $\overline{TTS}$  input initiates a “fall-through” action. If the top location of the stack is empty, data is loaded into the stack and the input register is re-initialized. Note that this initialization is postponed until PL is LOW again. Thus, automatic FIFO action is achieved by connecting the  $\overline{IRF}$  output to the  $\overline{TTS}$  input.

An RS Flip-Flop (the Request Initialization Flip-Flop shown in Figure 10) in the control section records the fact that data has been transferred to the stack. This prevents multiple entry of the same word into the stack despite the fact the  $\overline{IRF}$  and  $\overline{TTS}$  may still be LOW. The Request Initialization Flip-Flop is not cleared until PL goes LOW. Once in the stack, data falls through the stack automatically, pausing only when it is necessary to wait for an empty next location. In the 74F403A as in most modern FIFO designs, the  $\overline{MR}$  input only initializes the stack control section and does not clear the data.

**OUTPUT REGISTER (DATA EXTRACTION)**

The Output Register receives 4-bit data words from the bottom stack location, stores it and outputs data on a 3-STATE 4-bit parallel data bus or on a 3-STATE serial data bus. The output section generates and receives necessary status and control signals. Figure 3 is a conceptual logic diagram of the output section.

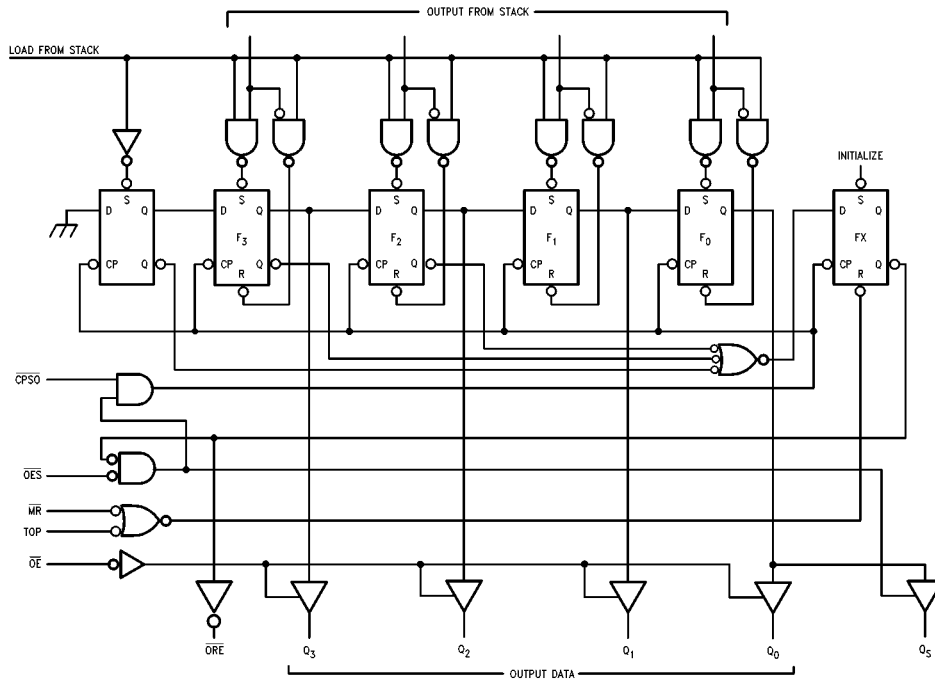

FIGURE 3. Conceptual Output Section

**Parallel Data Extraction**— When the FIFO is empty after a LOW pulse is applied to MR, the Output Register Empty ( $\overline{ORE}$ ) output is LOW. After data has been entered into the FIFO and has fallen through to the bottom stack location, it is transferred into the Output Register provided the “Transfer Out Parallel” (TOP) input is HIGH. As a result of the data transfer  $\overline{ORE}$  goes HIGH, indicating valid data on the data outputs (provided the 3-STATE buffer is enabled). TOP can now be used to clock out the next word. When TOP goes LOW,  $\overline{ORE}$  will go LOW indicating that the output data has been extracted, but the data itself remains on the output bus until the next HIGH level at TOP permits the transfer of the next word (if available) into the Output Register. During parallel data extraction  $\overline{CPSO}$  should be LOW. TOS should be grounded for single slice operation or connected to the appropriate  $\overline{ORE}$  for expanded operation (see Expansion section).

TOP is not edge triggered. Therefore, if TOP goes HIGH before data is available from the stack, but data does become available before TOP goes LOW again, that data will be transferred into the Output Register. However, internal control circuitry prevents the same data from being

transferred twice. If TOP goes HIGH and returns to LOW before data is available from the stack,  $\overline{ORE}$  remains LOW indicating that there is no valid data at the outputs.

**Serial Data Extraction**— When the FIFO is empty after a LOW pulse is applied to MR, the Output Register empty ( $\overline{ORE}$ ) output is LOW. After data has been entered into the FIFO and has fallen through to the bottom stack location, it is transferred into the Output Register provided TOS is LOW and TOP is HIGH. As a result of the data transfer  $\overline{ORE}$  goes HIGH indicating valid data in the register. The 3-STATE Serial Data Output,  $Q_5$ , is automatically enabled and puts the first data bit on the output bus. Data is serially shifted out on the HIGH-to-LOW transition of  $\overline{CPSO}$ . To prevent false shifting,  $\overline{CPSO}$  should be LOW when the new word is being loaded into the Output Register. The fourth transition empties the shift register, forces  $\overline{ORE}$  output LOW and disables the serial output,  $Q_5$  (refer to Figure 3). For serial operation the  $\overline{ORE}$  output may be tied to the TOS input, requesting a new word from the stack as soon as the previous one has been shifted out.

**EXPANSION**

**Vertical Expansion—** The 74F403A may be vertically expanded to store more words without external parts. The interconnection is necessary to form a 46-word by 4-bit FIFO are shown in Figure 4. Using the same technique, and FIFO of  $(15n + 1)$ -words by 4-bits can be constructed, where  $n$  is the number of devices. Note that expansion does not sacrifice any of the 74F403A's flexibility for serial/parallel input and output.

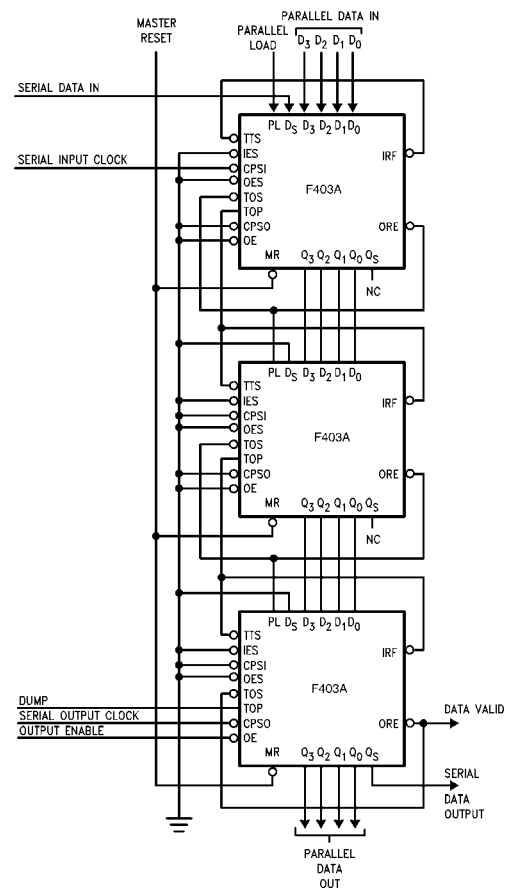

**FIGURE 4. A Vertical Expansion Scheme**

**Horizontal and Vertical Expansion—** The 74F403A can be expanded in both the horizontal and vertical directions without any external parts and without sacrificing any of its FIFO's flexibility for serial/parallel input and output. The interconnections necessary to form a 31-word by 16-bit FIFO are shown in Figure 6. Using the same technique, any FIFO of  $(15m + 1)$ -words by  $(4n)$ -bits can be constructed, where  $m$  is the number of devices in a column and  $n$  is the number of devices in a row. Figure 7 and Figure 8 show the timing diagrams for serial data entry and extraction for the 31-word by 16-bit FIFO shown in Figure 6. The final position of data after serial insertion of 496 bits into the FIFO array of Figure 6 is shown in Figure 9.

**Interlocking Circuitry—** Most conventional FIFO designs provide status signals analogous to  $\overline{\text{IRF}}$  and  $\overline{\text{ORE}}$ . However, when these devices are operated in arrays, variations in unit to unit operating speed require external gating to assure all devices have completed an operation. The 74F403A incorporates simple but effective "master/slave" interlocking circuitry to eliminate the need for external gating.

In the 74F403A array of Figure 6 devices 1 and 5 are defined as "row masters" and the other devices are slaves to the master in their row. No slave in a given row will initialize its Input Register until it has received LOW on its  $\overline{\text{IES}}$  input from a row master or a slave of higher priority.

In a similar fashion, the  $\overline{\text{ORE}}$  outputs of slaves will not go HIGH until their  $\overline{\text{OES}}$  inputs have gone HIGH. This interlocking scheme ensures that new input data may be accepted by the array when the  $\overline{\text{IRF}}$  output of the final slave in that row goes HIGH and that output data for the array may be extracted when the  $\overline{\text{ORE}}$  of the final slave in the output row goes HIGH.

The row master is established by connecting its  $\overline{\text{IES}}$  input to ground while a slave receives its  $\overline{\text{IES}}$  input from the  $\overline{\text{IRF}}$  output of the next higher priority device. When an array of 74F403A FIFOs is initialized with a LOW on the  $\overline{\text{MR}}$  inputs of all devices, the  $\overline{\text{IRF}}$  outputs of all devices will be HIGH. Thus, only the row master receives a LOW on the  $\overline{\text{IES}}$  input during initialization. Figure 10 is a conceptual logic diagram of the internal circuitry which determines master/slave operation. Whenever  $\overline{\text{MR}}$  and  $\overline{\text{IES}}$  are LOW, the Master Latch is set. Whenever  $\overline{\text{TTS}}$  goes LOW the Request Initialization Flip-Flop will be set. If the Master Latch is HIGH, the Input Register will be immediately initialized and the Request Initialization Flip-Flop reset. If the Master Latch is reset, the Input Register is not initialized until  $\overline{\text{IES}}$  goes LOW. In array operation, activating the  $\overline{\text{TTS}}$  initiates a ripple input register initialization from the row master to the last slave.

A similar operation takes place for the output register. Either a  $\overline{\text{TOS}}$  or  $\overline{\text{TOP}}$  input initiates a load-from-stack operation and sets the  $\overline{\text{ORE}}$  Request Flip-Flop. If the Master Latch is set, the last Output Register Flip-Flop is set and  $\overline{\text{ORE}}$  goes HIGH. If the Master Latch is reset, the  $\overline{\text{ORE}}$  output will be LOW until an  $\overline{\text{OES}}$  input is received.

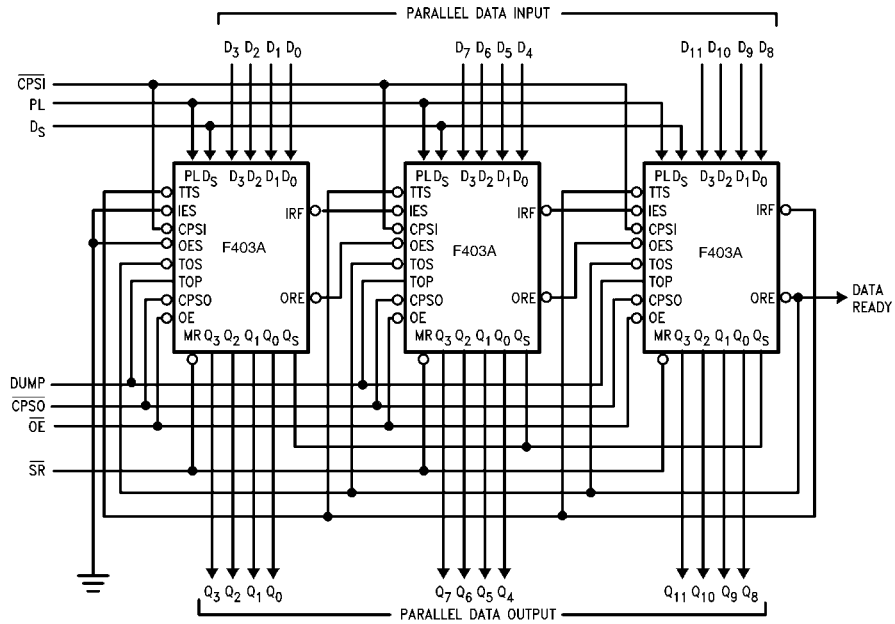

FIGURE 5. A Horizontal Expansion Scheme

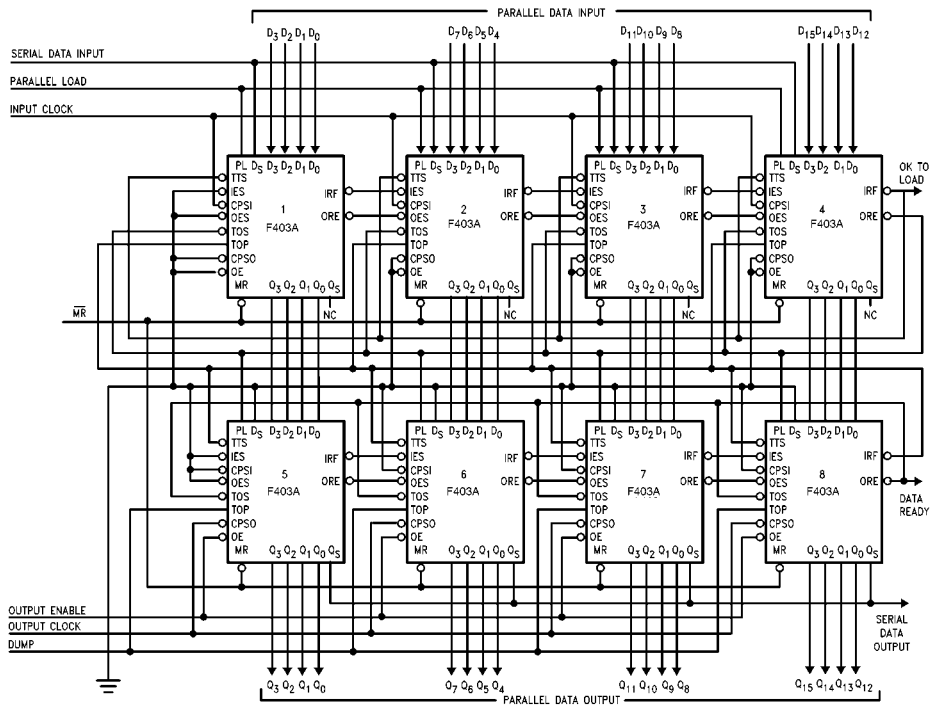

FIGURE 6. A 31 x 16 FIFO Array  
GRAPHIC 00953610

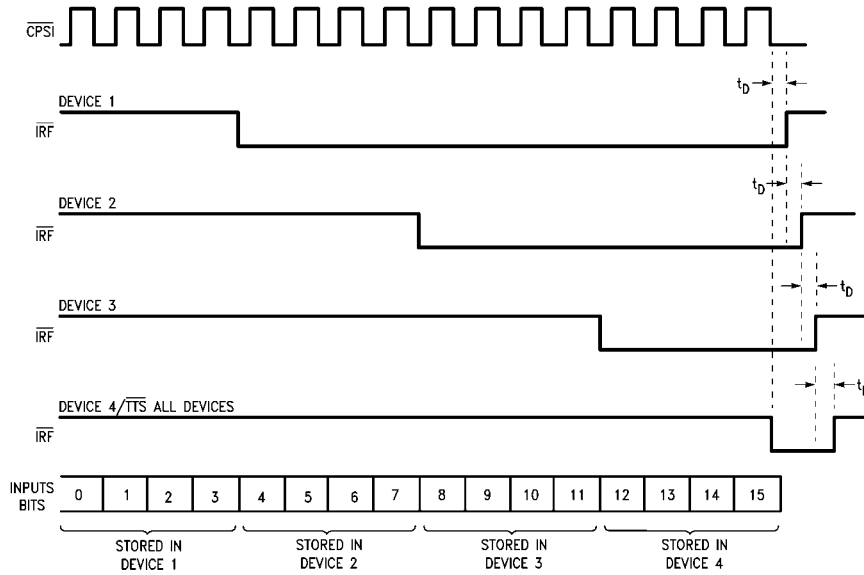

FIGURE 7. Serial Data Entry for Array of Figure 6

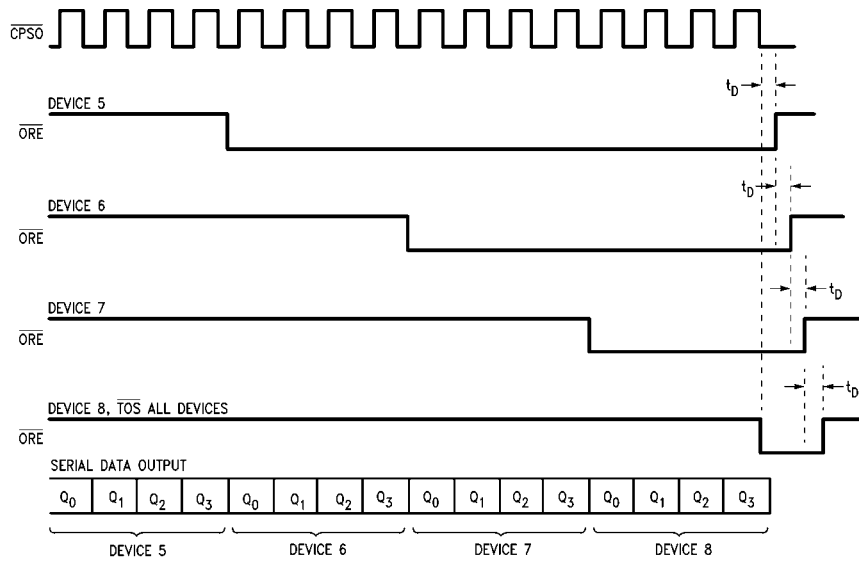

FIGURE 8. Serial Data Extraction for Array of Figure 6



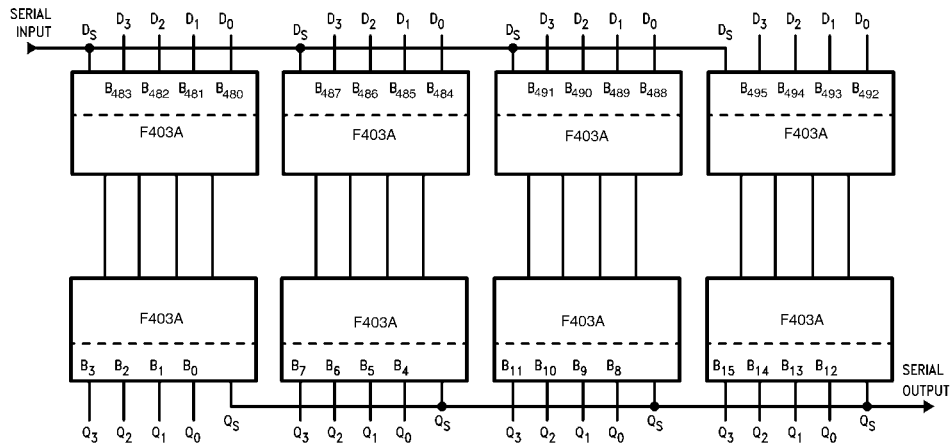

FIGURE 9. Final Position of a 496-Bit Serial Input

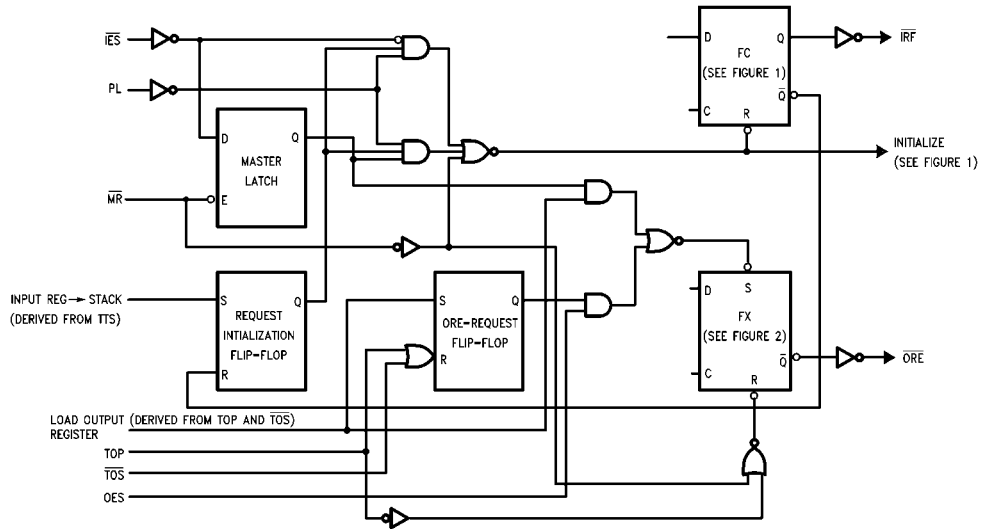

FIGURE 10. Conceptual Diagram, Interlocking Circuitry

**Absolute Maximum Ratings** (Note 1)

Storage Temperature	-65°C to +150°C
Ambient Temperature under Bias	-55°C to +125°C
Junction Temperature under Bias	-55°C to +175°C
V <sub>CC</sub> Pin Potential to Ground Pin	-0.5V to +7.0V
Input Voltage (Note 2)	-0.5V to +7.0V
Input Current (Note 2)	-30 mA to +5.0 mA
Voltage Applied to Output	
In HIGH State (with V <sub>CC</sub> = 0V)	
Standard Output	-0.5V to V <sub>CC</sub>
3-STATE Output	-0.5V to +5.5V
Current Applied to Output	
in LOW State (Max)	twice the rated I <sub>OL</sub> (mA)
ESD Last Passing Voltage (Min)	4000V

**Recommended Operating Conditions**

Free Air Ambient Temperature	0°C to +70°C
Supply Voltage	+4.5V to +5.5V

**Note 1:** Absolute maximum ratings are values beyond which the device may be damaged or have its useful life impaired. Functional operation under these conditions is not implied.

**Note 2:** Either voltage limit or current limit is sufficient to protect inputs.

**DC Electrical Characteristics**

Symbol	Parameter	Min	Type	Max	Units	V <sub>CC</sub>	Conditions
V <sub>IH</sub>	Input HIGH Voltage	2.0			V		Recognized as a HIGH Signal
V <sub>IL</sub>	Input LOW Voltage			0.8	V		Recognized as a LOW Signal
V <sub>CD</sub>	Input Clamp Diode Voltage			-1.5	V	Min	I <sub>IN</sub> = -18 mA
V <sub>OH</sub>	Output HIGH Voltage	10% V <sub>CC</sub>		2.5	V	Min	I <sub>OH</sub> = -400 μA ( $\overline{IRF}$ , $\overline{ORE}$ )
		10% V <sub>CC</sub>		2.5			I <sub>OH</sub> = -5.7 mA (Q <sub>n</sub> , Q <sub>s</sub> )
		5% V <sub>CC</sub>		2.7			I <sub>OH</sub> = -400 μA ( $\overline{IRF}$ , $\overline{ORE}$ )
		5% V <sub>CC</sub>		2.7			I <sub>OH</sub> = -5.7 mA (Q <sub>n</sub> , Q <sub>s</sub> )
V <sub>OL</sub>	Output LOW Voltage	10% V <sub>CC</sub>		0.5	V	Min	I <sub>OL</sub> = 8 mA ( $\overline{IRF}$ , $\overline{ORE}$ )
		10% V <sub>CC</sub>		0.5			I <sub>OL</sub> = 16 mA (Q <sub>n</sub> , Q <sub>s</sub> )
I <sub>IH</sub>	Input HIGH Current			20	μA	Max	V <sub>IN</sub> = 2.7V
I <sub>BVI</sub>	Input HIGH Current Breakdown Test			100	μA	Max	V <sub>IN</sub> = 7.0V
I <sub>IL</sub>	Input LOW Current			-0.4	mA	Max	V <sub>IN</sub> = 0.5V
I <sub>OZH</sub>	Output Leakage Current			50	μA	Max	V <sub>OUT</sub> = 2.7V
I <sub>OZL</sub>	Output Leakage Current			-50	μA	Max	V <sub>OUT</sub> = 0.5V
I <sub>OS</sub>	Output Short-Circuit Current	-20		-130	mA	Max	V <sub>OUT</sub> = 0V
I <sub>CEX</sub>	Output HIGH Leakage Current			250	μA	Max	V <sub>OUT</sub> = V <sub>CC</sub>
I <sub>CCL</sub>	Power Supply Current			170	mA	Max	V <sub>0</sub> = LOW

AC Electrical Characteristics							
Symbol	Parameter	$T_A = +25^\circ\text{C}$ $V_{CC} = +5.0\text{V}$ $C_L = 50\text{ pF}$		$T_A = 0^\circ\text{ to } +70^\circ\text{C}$ $V_{CC} = +5.0\text{V}$ $C_L = 50\text{ pF}$		Units	Figure Number
		Min	Max	Min	Max		
$t_{PHL}$	Propagation Delay, Negative-Going $\overline{CPSI}$ to IRF Output	7.5	14.0	7.0	15.0	ns	Figure 11 Figure 12
$t_{PLH}$	Propagation Delay, Negative-Going $\overline{TTS}$ to IRF	11.0	20.5	10.0	22.5		
$t_{PLH}$ $t_{PHL}$	Propagation Delay, Negative-Going $\overline{CPSO}$ to $Q_S$ Output	8.5 8.0	17.0 14.5	7.5 7.0	18.5 15.5	ns	Figure 13 Figure 14
$t_{PLH}$ $t_{PHL}$	Propagation Delay, Positive-Going TOP to Outputs $Q_0$ - $Q_3$	10.0 8.5	18.0 15.5	9.0 8.0	20.0 16.5	ns	Figure 15
$t_{PHL}$	Propagation Delay, Negative-Going $\overline{CPSO}$ to $\overline{ORE}$	9.5	17.5	9.0	19.0	ns	Figure 13 Figure 14
$t_{PHL}$	Propagation Delay, Negative-Going TOP to $\overline{ORE}$	8.0	15.0	7.5	16.5	ns	Figure 15
$t_{PLH}$	Propagation Delay, Positive-Going TOP or $\overline{ORE}$	12.5	22.0	11.5	25.0		
$t_{PLH}$	Propagation Delay, Negative-Going TOS to Positive Going $\overline{ORE}$	12.5	22.0	11.0	25.0	ns	Figure 13 Figure 14
$t_{PHL}$	Propagation Delay, Positive-Going PL to Negative-Going $\overline{IRF}$	7.0	13.0	6.5	14.0	ns	Figure 17 Figure 18
$t_{PLH}$	Propagation Delay, Negative-Going PL to Positive-Going $\overline{IRF}$	9.5	17.0	8.5	19.5		
$t_{PLH}$	Propagation Delay, Apostatize-Going $\overline{OES}$ to $\overline{ORE}$	10.0	18.0	9.0	20.5	ns	
$t_{PLH}$	Propagation Delay, Positive-Going IES to Positive-Going $\overline{IRF}$	8.5	15.5	7.5	17.5	ns	Figure 18
$t_{PLH}$	Propagation Delay, $\overline{MR}$ to IRF	8.0	15.0	7.5	17.0	ns	
$t_{PHL}$	Propagation Delay, $\overline{MR}$ to $\overline{ORE}$	9.0	16.0	8.0	17.5	ns	
$t_{PZH}$ $t_{PZL}$	Propagation Delay, $\overline{OE}$ to $Q_0, Q_1, Q_2, Q_3$	2.5 2.5	6.5 7.5	2.0 2.0	8.0 8.5	ns	
$t_{PHZ}$ $t_{PLZ}$	Propagation Delay, $\overline{OE}$ to $Q_0, Q_1, Q_2, Q_3$	2.5 2.5	6.5 7.5	2.0 2.0	8.0 8.0		
$t_{PZH}$ $t_{PZL}$	Propagation Delay, Negative-Going $\overline{OES}$ to $Q_S$	5.5 5.5	12.0 14.0	5.0 5.0	15.0 15.0	ns	
$t_{PHZ}$ $t_{PLZ}$	Propagation Delay, Negative-Going $\overline{OES}$ to $Q_S$	5.5 5.5	12.0 14.5	5.0 5.0	14.0 16.0		

AC Electrical Characteristics (Continued)							
Symbol	Parameter	T <sub>A</sub> = +25°C V <sub>CC</sub> = +5.0V C <sub>L</sub> = 50 pF		T <sub>A</sub> = 0° to +70°C V <sub>CC</sub> = +5.0V C <sub>L</sub> = 50 pF		Units	Figure Number
		Min	Max	Min	Max		
t <sub>PZH</sub>	Turn On Time	8.5	21.0	8.0	24.0	ns	
t <sub>PZL</sub>	$\overline{\text{TOS}}$ to Q <sub>S</sub>	8.5	20.0	8.0	21.0		
t <sub>DFT</sub>	Fall Through Time	45.0	80.0	35.0	95.0	ns	Figure 16
t <sub>AP</sub>	Parallel Appearance Time, $\overline{\text{ORE}}$ to Q <sub>0</sub> -Q <sub>3</sub>	-10.0	-1.0	-10.0	-1.0	ns	
t <sub>AS</sub>	Serial Appearance Time, $\overline{\text{ORE}}$ to Q <sub>S</sub>	-10.0	2.0	-10.0	2.0		
AC Operating Requirements							
Symbol	Parameter	T <sub>A</sub> = +25°C V <sub>CC</sub> = +5.0V		T <sub>A</sub> = 0°C to +70°C V <sub>CC</sub> = +5.0V		Units	Figure Number
		Min	Max	Min	Max		
t <sub>S</sub> (H)	Set-up Time HIGH or LOW	1.0		1.0		ns	Figure 11 Figure 12
t <sub>S</sub> (L)	D <sub>S</sub> to Negative $\overline{\text{CPSI}}$	1.0		1.0			
t <sub>H</sub> (H)	Hold Time, HIGH or LOW	3.5		3.5		ns	Figure 11 Figure 12 Figure 17 Figure 18
t <sub>H</sub> (L)	D <sub>S</sub> to $\overline{\text{CPSI}}$	3.5		3.5			
t <sub>S</sub> (L)	Set-up Time, LOW $\overline{\text{TTS}}$ to $\overline{\text{IRF}}$ Serial or Parallel Mode	0		0		ns	Figure 13 Figure 14
t <sub>S</sub> (L)	Set-up Time, LOW Negative-Going $\overline{\text{ORE}}$ to Negative-Going $\overline{\text{TOS}}$	0		0		ns	Figure 12 Figure 17 Figure 18
t <sub>S</sub> (L)	Set-up Time, LOW Negative-Going $\overline{\text{IES}}$ to $\overline{\text{CPSI}}$	3.0		4.0		ns	Figure 13 Figure 14
t <sub>S</sub> (L)	Set-up Time, LOW Negative-Going $\overline{\text{TTS}}$ to $\overline{\text{CPSI}}$	14.0		15.5		ns	Figure 12
t <sub>S</sub> (H)	Set-up Time, HIGH or LOW	0		0		ns	
t <sub>S</sub> (L)	Parallel Inputs to PL	0		0			
t <sub>H</sub> (H)	Hold Time, HIGH or LOW	2.0		2.5		ns	Figure 11 Figure 12
t <sub>H</sub> (L)	Parallel Inputs to PL	2.0		2.5			
t <sub>W</sub> (H)	$\overline{\text{CPSI}}$ Pulse Width	5.0		6.0		ns	Figure 17 Figure 18
t <sub>W</sub> (L)	HIGH or LOW	3.0		5.0			
t <sub>W</sub> (H)	PL Pulse Width, HIGH	4.0		5.0		ns	Figure 11 Figure 12 Figure 13 Figure 14
t <sub>W</sub> (L)	$\overline{\text{TTS}}$ Pulse Width, LOW Serial or Parallel Mode	3.5		4.0		ns	Figure 16
t <sub>W</sub> (L)	$\overline{\text{MR}}$ Pulse Width, LOW	3.5		4.0		ns	Figure 15
t <sub>W</sub> (H)	TOP Pulse Width	4.5		5.5		ns	Figure 13 Figure 14
t <sub>W</sub> (L)	HIGH or LOW	3.5		4.0			
t <sub>W</sub> (H)	$\overline{\text{CPSO}}$ Pulse Width	4.5		5.5		ns	Figure 16
t <sub>W</sub> (L)	HIGH or LOW	3.0		4.0			
t <sub>REC</sub>	Recovery Time $\overline{\text{MR}}$ to Any Input	5.0		5.5		ns	

### Timing Waveforms

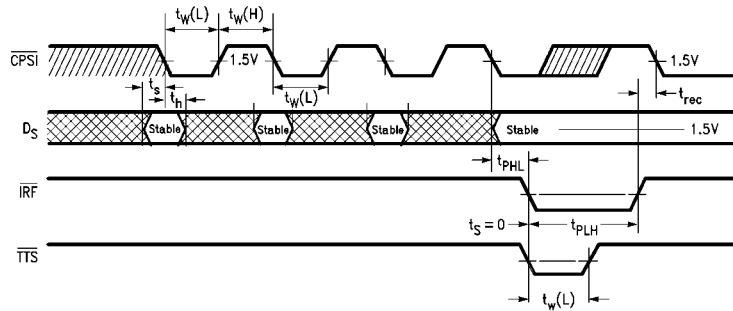

Conditions: stack not full,  $\overline{IES}$ , PL LOW

**FIGURE 11. Serial Input, Unexpanded or Master Operation**

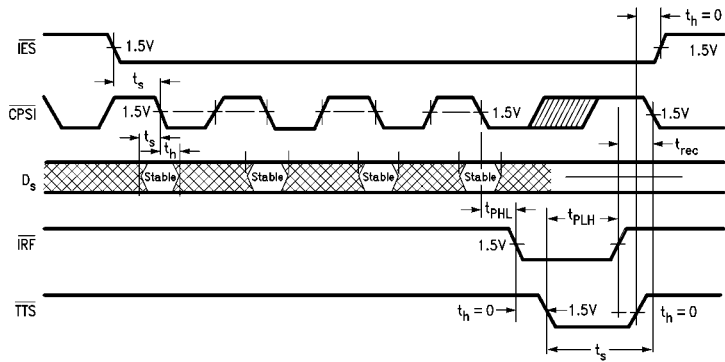

Conditions: stack not full,  $\overline{IES}$  HIGH when initiated, PL LOW

**FIGURE 12. Serial Input, Expanded Slave Operation**

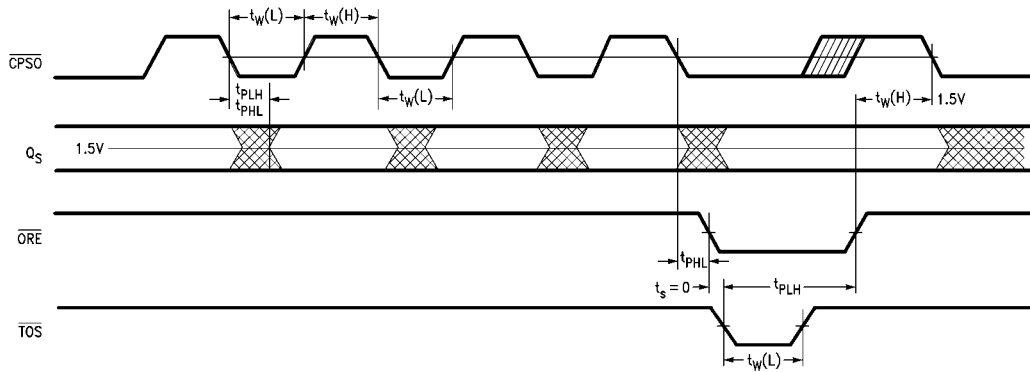

Conditions: data in stack, TOP HIGH,  $\overline{IES}$  LOW when initiated,  $\overline{OES}$  LOW

**FIGURE 13. Serial Output, Unexpanded or Master Operation**

Timing Waveforms (Continued)

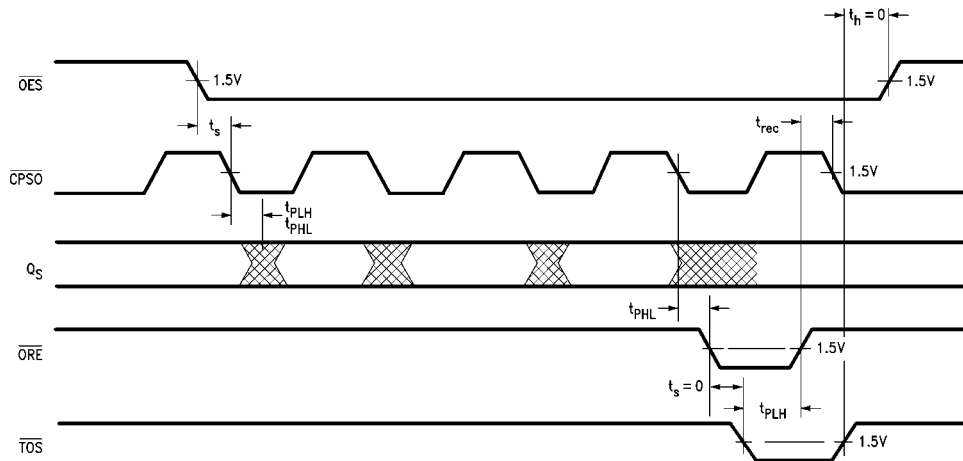

Conditions: data in stack, TOP HIGH,  $\overline{IES}$  HIGH when initiated

FIGURE 14. Serial Output, Slave Operation

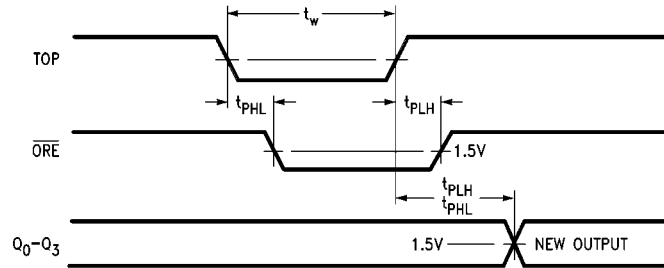

Conditions:  $\overline{IES}$  LOW when initiated,  $\overline{OE}$ ,  $\overline{CPSO}$  LOW; data available in stack

FIGURE 15. Parallel Output, 4-Bit Word or Master in Parallel Expansion

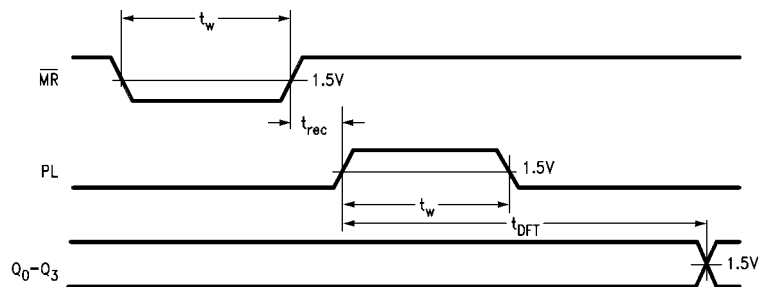

Conditions:  $\overline{TTS}$  connected to  $\overline{IRF}$ ,  $\overline{TOS}$  connected to  $\overline{ORE}$ ,  $\overline{IES}$ ,  $\overline{OES}$ ,  $\overline{OE}$ ,  $\overline{CPSO}$  LOW, TOP HIGH

FIGURE 16. Fall Through Time

Timing Waveforms (Continued)

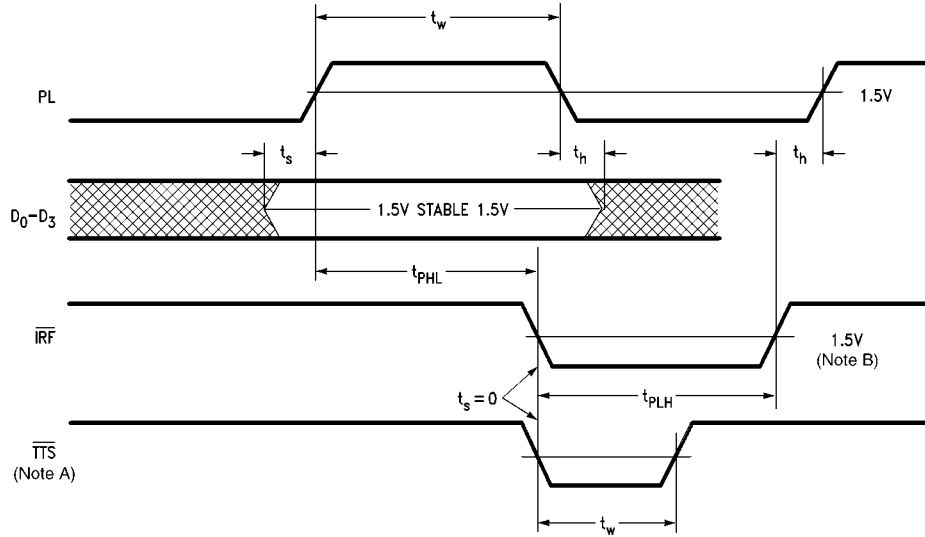

Conditions: stack not full,  $\overline{IES}$  LOW when initialized

NOTE A:  $\overline{TTS}$  normally connected to  $\overline{IRF}$ .

NOTE B: If stack is full,  $\overline{IRF}$  will stay LOW.

FIGURE 17. Parallel Load Mode, 4-Bit Word (Unexpanded) or Master in Parallel Expansion

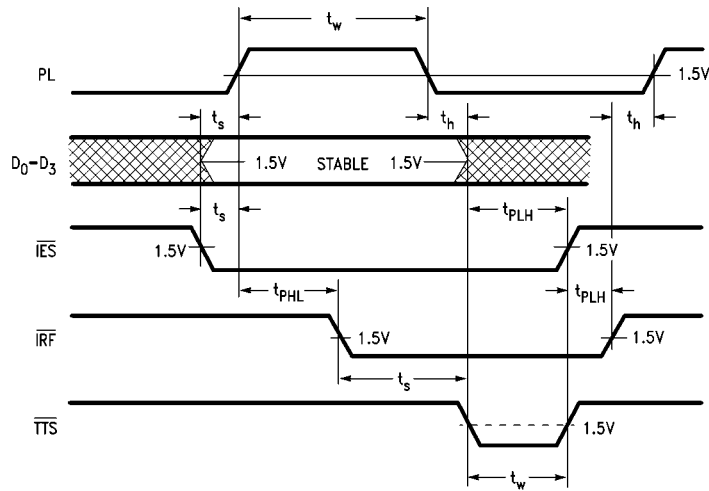

Conditions: stack not full, device initialized (Note 3) with  $\overline{IES}$  HIGH

FIGURE 18. Parallel Load, Slave Mode

Note 3: Initialization requires a master reset to occur after power has been applied.

**Physical Dimensions** inches (millimeters) unless otherwise noted

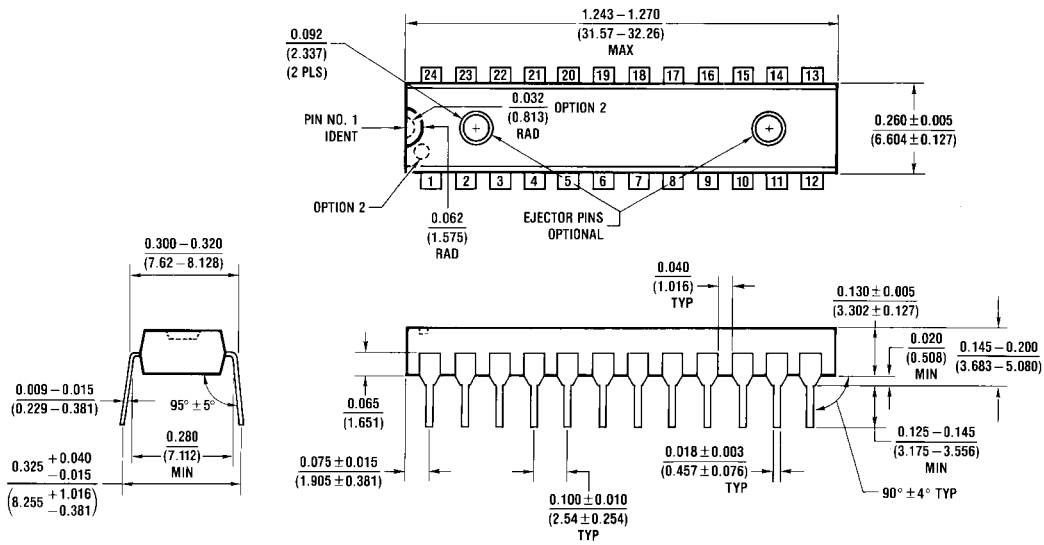

N24C (REV F)

**24-Lead Plastic Dual-In-Line Package (PDIP), JEDEC MS-100, 0.300 Wide Package Number N24C**

**LIFE SUPPORT POLICY**

FAIRCHILD'S PRODUCTS ARE NOT AUTHORIZED FOR USE AS CRITICAL COMPONENTS IN LIFE SUPPORT DEVICES OR SYSTEMS WITHOUT THE EXPRESS WRITTEN APPROVAL OF THE PRESIDENT OF FAIRCHILD SEMICONDUCTOR CORPORATION. As used herein:

1. Life support devices or systems are devices or systems which, (a) are intended for surgical implant into the body, or (b) support or sustain life, and (c) whose failure to perform when properly used in accordance with instructions for use provided in the labeling, can be reasonably expected to result in a significant injury to the user.
2. A critical component in any component of a life support device or system whose failure to perform can be reasonably expected to cause the failure of the life support device or system, or to affect its safety or effectiveness.

[www.fairchildsemi.com](http://www.fairchildsemi.com)