

8256AH

Multifunction Microprocessor Support Controller

The Intel 8256AH Multifunction Universal Asynchronous Receiver-Transmitter (MUART) combines five commonly used functions into a single 40-pin device. It is designed to interface to the 8086/88, iAPX 186/188, and 8051 to perform serial communications, parallel I/O, timing, event counting, and priority interrupt functions. All of these functions are fully programmable through nine internal registers. In addition, the five timer/counters and two parallel I/O ports can be accessed directly by the microprocessor.

Rochester Electronics Manufactured Components

Rochester branded components are manufactured using either die/wafers purchased from the original suppliers or Rochester wafers recreated from the original IP. All recreations are done with the approval of the OCM.

Parts are tested using original factory test programs or Rochester developed test solutions to guarantee product meets or exceeds the OCM data sheet.

Quality Overview

- ISO-9001
- AS9120 certification
- Qualified Manufacturers List (QML) MIL-PRF-38535
 - Class Q Military
 - Class V Space Level
- Qualified Suppliers List of Distributors (QSLD)
 - Rochester is a critical supplier to DLA and meets all industry and DLA standards.

Rochester Electronics, LLC is committed to supplying products that satisfy customer expectations for quality and are equal to those originally supplied by industry manufacturers.

The original manufacturer's datasheet accompanying this document reflects the performance and specifications of the Rochester manufactured version of this device. Rochester Electronics guarantees the performance of its semiconductor products to the original OEM specifications. 'Typical' values are for reference purposes only. Certain minimum or maximum ratings may be based on product characterization, design, simulation, or sample testing.



8256AH MULTIFUNCTION MICROPROCESSOR SUPPORT CONTROLLER

- Programmable Serial Asynchronous Communications Interface for 5-, 6-, 7-, or 8-Bit Characters, 1, 1½, or 2 Stop Bits, and Parity Generation
- On-Board Baud Rate Generator Programmable for 13 Common Baud Rates up to 19.2 KBits/Second, or an External Baud Clock Maximum of 1M Bit/Second
- Five 8-Bit Programmable Timer/Counters; Four Can Be Cascaded to Two 16-Bit Timer/Counters
- Two 8-Bit Programmable Parallel I/O Ports; Port 1 Can Be Programmed for Port 2 Handshake Controls and Event Counter Inputs
- Eight-Level Priority Interrupt Controller Programmable for 8085 or iAPX 86, iAPX 88 Systems and for Fully Nested Interrupt Capability
- Programmable System Clock to 1 ×, 2 ×, 3 ×, or 5 × 1.024 MHz

The Intel® 8256AH Multifunction Universal Asynchronous Receiver-Transmitter (UART) combines five commonly used functions into a single 40-pin device. It is designed to interface to the 8086/88, iAPX 186/188, and 8051 to perform serial communications, parallel I/O, timing, event counting, and priority interrupt functions. All of these functions are fully programmable through nine internal registers. In addition, the five timer/counters and two parallel I/O ports can be accessed directly by the microprocessor.

3

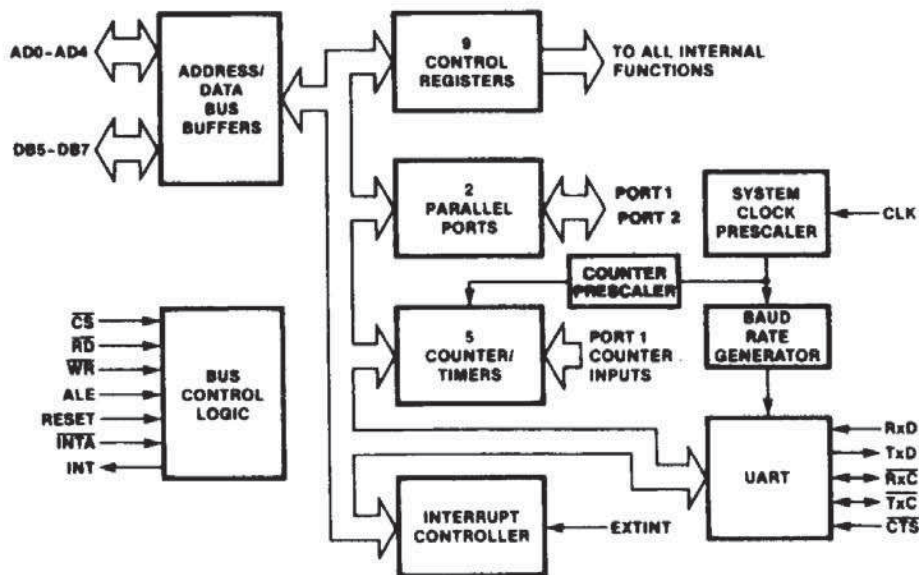

Figure 1. MUART Block Diagram

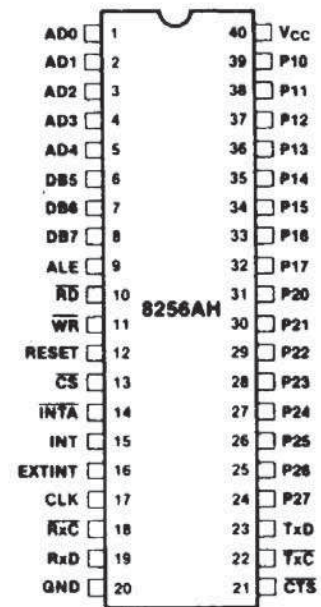

Figure 2. MUART Pin Configuration

Table 1. Pin Description

Symbol	Pin	Type	Name and Function
AD0-AD4 DB5-DB7	1-5 6-8	I/O	ADDRESS/DATA: Three-state address/data lines which interface to the lower 8 bits of the microprocessor's multiplexed address/data bus. The 5-bit address is latched on the falling edge of ALE. In the 8-bit mode, AD0-AD3 are used to select the proper register, while AD1-AD4 are used in the 16-bit mode. AD4 in the 8-bit mode is ignored as an address, while AD0 in the 16-bit mode is used as a second chip select, active low.
ALE	9	I	ADDRESS LATCH ENABLE: Latches the 5 address lines on AD0-AD4 and \overline{CS} on the falling edge.
\overline{RD}	10	I	READ CONTROL: When this signal is low, the selected register is gated onto the data bus.
\overline{WR}	11	I	WRITE CONTROL: When this signal is low, the value on the data bus is written into the selected register.
RESET	12	I	RESET: An active high pulse on this pin forces the chip into its initial state. The chip remains in this state until control information is written.
\overline{CS}	13	I	CHIP SELECT: A low on this signal enables the MUART. It is latched with the address on the falling edge of ALE, and \overline{RD} and \overline{WR} have no effect unless \overline{CS} was latched low during the ALE cycle.
\overline{INTA}	14	I	INTERRUPT ACKNOWLEDGE: If the MUART has been enabled to respond to interrupts, this signal informs the MUART that its interrupt request is being acknowledged by the microprocessor. During this acknowledgement the MUART puts an RSTn instruction on the data bus for the 8-bit mode or a vector for the 16-bit mode.
INT	15	O	INTERRUPT REQUEST: A high signals the microprocessor that the MUART needs service.
EXTINT	16	I	EXTERNAL INTERRUPT: An external device can request interrupt service through this input. The input is level sensitive (high), therefore it must be held high until an \overline{INTA} occurs or the interrupt address register is read.
CLK	17	I	SYSTEM CLOCK: The reference clock for the baud rate generator and the timers.
RxC	18	I/O	RECEIVE CLOCK: If the baud rate bits in the Command Register 2 are all 0, this pin is an input which clocks serial data into the RxD pin on the rising edge of RxC. If baud rate bits in Command Register 2 are programmed from 1-0FH, this pin outputs a square wave whose rising edge indicates when the data on RxD is being sampled. This output remains high during start, stop, and parity bits.
RxD	19	I	RECEIVE DATA: Serial data input.
GND	20	PS	GROUND: Power supply and logic ground reference.

Table 1. Pin Description (Continued)

Symbol	Pin	Type	Name and Function
$\overline{\text{CTS}}$	21	I	CLEAR TO SEND: This input enables the serial transmitter. If 1, 1.5, or 2 stop bits are selected $\overline{\text{CTS}}$ is level sensitive. As long as $\overline{\text{CTS}}$ is low, any character loaded into the transmitter buffer register will be transmitted serially. A single negative going pulse causes the transmission of a single character previously loaded into the transmitter buffer register. If a baud rate from 1–0FH is selected, $\overline{\text{CTS}}$ must be low for at least $\frac{1}{32}$ of a bit, or it will be ignored. If the transmitter buffer is empty, this pulse will be ignored. If this pulse occurs during the transmission of a character up to the time where $\frac{1}{2}$ the first (or only) stop bit is sent out, it will be ignored. If it occurs afterwards, but before the end of the stop bits, the next character will be transmitted immediately following the current one. If $\overline{\text{CTS}}$ is still high when the transmitter register is sending the last stop bit, the transmitter will enter its idle state until the next high-to-low transition on $\overline{\text{CTS}}$ occurs. If 0.75 stop bits is chosen, the $\overline{\text{CTS}}$ input is edge sensitive. A negative edge on $\overline{\text{CTS}}$ results in the immediate transmission of the next character. The length of the stop bits is determined by the time interval between the beginning of the first stop bit and the next negative edge on $\overline{\text{CTS}}$. A high-to-low transition has no effect if the transmitter buffer is empty or if the time interval between the beginning of the stop bit and next negative edge is less than 0.75 bits. A high or a low level or a low-to-high transition has no effect on the transmitter for the 0.75 stop bit mode.
TxC	22	I/O	TRANSMIT CLOCK: If the baud rate bits in command register 2 are all set to 0, this input clocks data out of the transmitter on the falling edge. If baud rate bits are programmed for 1 or 2, this input permits the user to provide a $32\times$ or $64\times$ clock which is used for the receiver and transmitter. If the baud rate bits are programmed for 3–0FH, the internal transmitter clock is output. As an output it delivers the transmitter clock at the selected bit rate. If $1\frac{1}{2}$ or 0.75 stop bits are selected, the transmitter divider will be asynchronously reset at the beginning of each start bit, immediately causing a high-to-low transition on TxC. TxC makes a high-to-low transition at the beginning of each serial bit, and a low-to-high transition at the center of each bit.
TxD	23	O	TRANSMIT DATA: Serial data output.
P27–P20	24–31	I/O	PARALLEL I/O PORT 2: Eight bit general purpose I/O port. Each nibble (4 bits) of this port can be either an input or an output. The outputs are latched whereas the input signals are not. Also, this port can be used as an 8-bit input or output port when using the two-wire handshake. In the handshake mode both inputs and outputs are latched.
P17–P10	32–39	I/O	PARALLEL I/O PORT 1: Each pin can be programmed as an input or an output to perform general purpose I/O. All outputs are latched whereas inputs are not. Alternatively these pins can serve as control pins which extend the functional spectrum of the chip.
V _{CC}	40	PS	POWER: +5V power supply.

FUNCTIONAL DESCRIPTION

The 8256AH Multi-Function Universal Asynchronous Receiver-Transmitter (MUART) combines five commonly used functions into a single 40-pin device. The MUART performs asynchronous serial communications, parallel I/O, timing, event counting, and interrupt control. For detailed application information, see Intel AP Note #153, Designing with the 8256.

Serial Communications

The serial communications portion of the MUART contains a full-duplex asynchronous receiver-transmitter (UART). A programmable baud rate generator is included on the MUART to permit a variety of operating speeds without external components. The UART can be programmed by the CPU for a variety of character sizes, parity generation and detection, error detection, and start/stop bit handling. The receiver checks the start and stop bits in the center of the bit, and a break halts the reception of data. The transmitter can send breaks and can be controlled by an external enable pin.

Parallel I/O

The MUART includes 16 bits of general purpose parallel I/O. Eight bits (Port 1) can be individually changed from input to output or used for special I/O functions. The other eight bits (Port 2) can be used as nibbles (4 bits) or as bytes. These eight bits also include a handshaking capability using two pins on Port 1.

Counter/Timers

There are five 8-bit counter/timers on the MUART. The timers can be programmed to use either a 1 kHz or 16 kHz clock generated from the system clock. Four of the 8-bit counter/timers can be cascaded to two 16-bit counter/timers, and one of the 8-bit counter/timers can be reset to its initial value by an external signal.

Interrupts

An eight-level priority interrupt controller can be configured for fully nested or normal interrupt priority. Seven of the eight interrupts service functions on the MUART (counter/timers, UART), and one external interrupt is provided which can be used for a particular function or for chaining interrupt controllers or more MUARTs. The MUART will support

8085 and 8086/88 systems with direct interrupt vectoring, or the MUART can be polled to determine the cause of the interrupt. If additional interrupt control capability is needed, the MUART's interrupt controller can be cascaded into another MUART, into an Intel 8259A Programmable Interrupt Controller, or into the interrupt controller of the iAPX 186/188 High-Integration Microprocessor.

INITIALIZATION

In general the MUART's functions are independent of each other and only the registers and bits associated with a particular function need to be initialized, not the entire chip. The command sequence is arbitrary since every register is directly addressable; however, **Command Byte 1** must be loaded first. To put the device into a fully operational condition, it is necessary to write the following commands:

```

Command byte 1
Command byte 2
Command byte 3
  Mode byte
    Port 1 control
    Set Interrupts

```

The modification register may be loaded if required for special applications; normally this operation is not necessary. The MUART should be reset before initialization. (Either a hardware or a software reset will do.)

INTERFACING

This section describes the hardware interface between the 8256 MUART and the 80186 microprocessor. Figure 3 displays the block diagram for this interface. The MUART can be interfaced to many other microprocessors using these basic principles.

In all cases the 8256 will be connected directly to the CPU's multiplexed address/data bus. If latches or data bus buffers are used in a system, the MUART should be on the microprocessor side of the address/data bus. The MUART latches the address internally on the falling edge of ALE. The address consists of Chip Select (CS) and four address lines. For 8-bit microprocessors, AD0-AD3 are the address lines. For 16-bit microprocessors, AD1-AD4 are the address lines; AD0 is used as a second chip select which is active low. Since chip select is internally latched along with the address, it does not have to remain active during the entire instruction cycle. As long as the chip select setup and hold times are met, it can be derived from multiplexed ad-

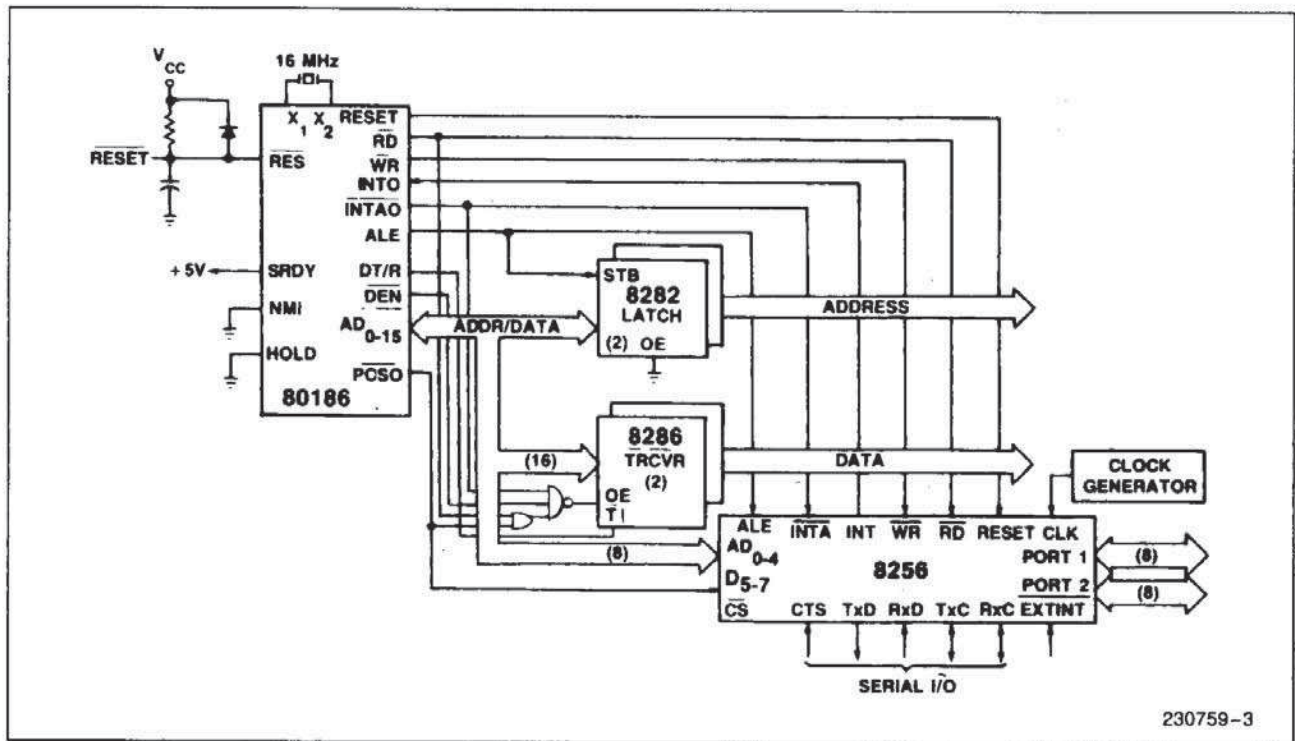

Figure 3. 80186/8256 Interface

dress/data lines or multiplexed address/status lines. When the 8256 is in the 16-bit mode, A0 serves as a second chip select. As a result the MUART's internal registers will all have even addresses since A0 must be zero to select the device. Normally the MUART will be placed on the lower data byte. If the MUART is placed on the upper data byte, the internal registers will be 512 address locations apart and the chip would occupy an 8k word address space.

DESCRIPTION OF THE REGISTERS

The following section will provide a description of the registers and define the bits within the registers where appropriate. Table 2 lists the registers and their addresses.

Command Register 1

L1	L0	S1	S0	BRKI	BITI	8086	FRQ
(0R)				(0W)			

FRQ—TIMER FREQUENCY SELECT

This bit selects between two frequencies for the five timers. If FRQ = 0, the timer input frequency is 16 kHz (62.5 μs). If FRQ = 1, the timer input frequency is 1 kHz (1 ms). The selected clock frequen-

cy is shared by all the counter/timers enabled for timing; thus, all timers must run with the same time base.

8086—8086 MODE ENABLE

This bit selects between 8085 mode and 8086/8088 mode. In 8085 mode (8086 = 0), A0 to A3 are used to address the internal registers, and an RSTn instruction is generated in response to the first \overline{INTA} . In 8086 mode (8086 = 1), A1 to A4 are used to address the internal registers, and A0 is used as an extra chip select (A0 must equal zero to be enabled). The response to \overline{INTA} is for 8086 interrupts where the first \overline{INTA} is ignored, and an interrupt vector (40H to 47H) is placed on the bus in response to the second \overline{INTA} .

BITI—INTERRUPT ON BIT CHANGE

This bit selects between one of two interrupt sources on Priority Level 1, either Counter/Timer 2 or Port 1 P17 interrupt. When this bit equals 0, Counter/Timer 2 will be mapped into Priority Level 1. If BITI equals 0 and Level 1 interrupt is enabled, a transition from 1 to 0 in Counter/Timer 2 will generate an interrupt request on Level 1. When BITI equals 1, Port 1 P17 external edge triggered interrupt source is mapped into Priority Level 1. In this case if Level 1 is enabled, a low-to-high transition on P17 generates an interrupt request on Level 1.

Table 2. MUART Registers

Read Registers								8085 Mode: AD3 AD2 AD1 AD0				Write Registers											
								8086 Mode: AD4 AD3 AD2 AD1															
L1	L0	S1	S0	BRKI	BITI	8086	FRQ	0	0	0	0	L1	L0	S1	S0	BRKI	BITI	8086	FRQ				
Command 1												Command 1											
PEN	EP	C1	C0	B3	B2	B1	B0	0	0	0	1	PEN	EP	C1	C0	B3	B2	B1	B0				
Command 2												Command 2											
0	RxE	IAE	NIE	0	SBRK	TBRK	0	0	0	1	0	SET	RxE	IAE	NIE	END	SBRK	TBRK	RST				
Command 3												Command 3											
T35	T24	T5C	CT3	CT2	P2C2	P2C1	P2C0	0	0	1	1	T35	T24	T5C	CT3	CT2	P2C2	P2C1	P2C0				
Mode												Mode											
P17	P16	P15	P14	P13	P12	P11	P10	0	1	0	0	P17	P16	P15	P14	P13	P12	P11	P10				
Port 1 Control												Port 1 Control											
L7	L6	L5	L4	L3	L2	L1	L0	0	1	0	1	L7	L6	L5	L4	L3	L2	L1	L0				
Interrupt Enable												Set Interrupts											
D7	D6	D5	D4	D3	D2	D1	D0	0	1	1	0	L7	L6	L5	L4	L3	L2	L1	L0				
Interrupt Address												Reset Interrupts											
D7	D6	D5	D4	D3	D2	D1	D0	0	1	1	1	D7	D6	D5	D4	D3	D2	D1	D0				
Receiver Buffer												Transmitter Buffer											
D7	D6	D5	D4	D3	D2	D1	D0	1	0	0	0	D7	D6	D5	D4	D3	D2	D1	D0				
Port 1												Port 1											
D7	D6	D5	D4	D3	D2	D1	D0	1	0	0	1	D7	D6	D5	D4	D3	D2	D1	D0				
Port 2												Port 2											
D7	D6	D5	D4	D3	D2	D1	D0	1	0	1	0	D7	D6	D5	D4	D3	D2	D1	D0				
Timer 1												Timer 1											
D7	D6	D5	D4	D3	D2	D1	D0	1	0	1	1	D7	D6	D5	D4	D3	D2	D1	D0				
Timer 2												Timer 2											
D7	D6	D5	D4	D3	D2	D1	D0	1	1	0	0	D7	D6	D5	D4	D3	D2	D1	D0				
Timer 3												Timer 3											
D7	D6	D5	D4	D3	D2	D1	D0	1	1	0	1	D7	D6	D5	D4	D3	D2	D1	D0				
Timer 4												Timer 4											
D7	D6	D5	D4	D3	D2	D1	D0	1	1	1	0	D7	D6	D5	D4	D3	D2	D1	D0				
Timer 5												Timer 5											
INT	RBF	TBE	TRE	BD	PE	OE	FE	1	1	1	1	0	RS4	RS3	RS2	RS1	RS0	TME	DSC				
Status												Modification											

BRKI—BREAK-IN DETECT ENABLE

If this bit equals 0, Port 1 P16 is a general purpose I/O port. When BRKI equals 1, the Break-In Detect feature is enabled on Port 1 P16. A Break-In condition is present on the transmission line when it is forced to the start bit voltage level by the receiving station. Port 1 P16 must be connected externally to the transmission line in order to detect a Break-In. A Break-In is polled by the MUART during the transmission of the last or only stop bit of a character.

A Break-In Detect is OR-ed with Break Detect in Bit 3 of the Status Register. The distinction can be made through the interrupt controller. If the transmit and receive interrupts are enabled, a Break-In will generate an interrupt on Level 5, the transmit interrupt, while Break will generate an interrupt on Level 4, the receive interrupt.

S0, S1—STOP BIT LENGTH

S1	S0	Stop Bit Length
0	0	1
0	1	1.5
1	0	2
1	1	0.75

The relationship of the number of stop bits and the function of input CTS is discussed in the Pin Description section under "CTS".

L0, L1—CHARACTER LENGTH

L1	L0	Character Length
0	0	8
0	1	7
1	0	6
1	1	5

Command Register 2

PEN	EP	C1	C0	B3	B2	B1	B0
(1R)				(1W)			

Programming bits 0 . . . 3 with values from 3H to FH enables the internal baud rate generator as a common clock source for the transmitter and receiver and determines its divider ratio.

Programming bits 0 . . . 3 with values of 1H or 2H enables input TxC as a common clock source for the transmitter and receiver. The external clock must

provide a frequency of either 32× or 64× the baud rate. The data transmission rates range from 0 . . . 32 Kbaud.

If bits 0 . . . 3 are set to 0, separate clocks must be input to pin RxC for the receiver and pin TxC for the transmitter. Thus, different baud rates can be used for transmission and reception. In this case, pre-scalers are disabled and the input serial clock frequency must match the baud rate. The input serial clock frequency can range from 0 MHz to 1.024 MHz.

B0, B1, B2, B3—BAUD RATE SELECT

These four bits select the bit clock's source, sampling rate, and serial rate for the internal baud rate generator.

B3	B2	B1	B0	Baud Rate	Sampling Rate
0	0	0	0	TxC, RxC	1
0	0	0	1	TxC/64	64
0	0	1	0	TxC/32	32
0	0	1	1	19200	32
0	1	0	0	9600	64
0	1	0	1	4800	64
0	1	1	0	2400	64
0	1	1	1	1200	64
1	0	0	0	600	64
1	0	0	1	300	64
1	0	1	0	200	64
1	0	1	1	150	64
1	1	0	0	110	64
1	1	0	1	100	64
1	1	1	0	75	64
1	1	1	1	50	64

The following table gives an overview of the function of pins TxC and RxC:

Bits 3 to 0 (Hex.)	TxC	RxC
0	Input: 1 × baud rate clock for the transmitter	Input: 1 × baud rate clock for the receiver
1, 2	Input: 32 × or 64 × baud rate for transmitter and receiver	Output: receiver bit clock with a low-to-high transition at data bit sampling time. Otherwise: high level
3 to F	Output: baud rate clock of the transmitter	Output: as above



As an output, RxC outputs a low-to-high transition at sampling time of every data bit of a character. Thus, data can be loaded, e.g., into a shift register externally. The transition occurs only if data bits of a character are present. It does not occur for start, parity, and stop bits (RxC = high).

As an output, TxC outputs the internal baud rate clock of the transmitter. There will be a high-to-low transition at every beginning of a bit.

C0, C1—SYSTEM CLOCK PRESCALER (BITS 4, 5)

Bits 4 and 5 define the system clock prescaler divider ratio. The internal operating frequency of 1.024 MHz is derived from the system clock.

C1	C0	Divider Ratio	Clock at Pin CLK
0	0	5	5.12 MHz
0	1	3	3.072 MHz
1	0	2	2.048 MHz
1	1	1	1.024 MHz

EP—EVEN PARITY (BIT 6)

EP = 0: Odd parity
EP = 1: Even parity

PEN—PARITY ENABLE (BIT 7)

Bit 7 enables parity generation and checking.

PEN = 0: No parity bit
PEN = 1: Even parity bit

The parity bit according to Command Register 2 bit 6 (see above) is inserted between the last data bit of a character and the first or only stop bit. The parity bit is checked during reception. A false parity bit generates an error indication in the Status Register and an Interrupt Request on Level 4.

Command Register 3

SET	RxE	IAE	NIW	END	SBRK	TBRK	RST
(2R)				(2W)			

Command Register 3 is different from the first two registers because it has a bit set/reset capability. Writing a byte with Bit 7 high sets any bits which were also high. Writing a byte with Bit 7 low resets

any bits which were high. If any bit 0–6 is low, no change occurs to that bit. When command Register 3 is read, bits 0, 3, and 7 will always be zero.

RST—RESET

If RST is set, the following events occur:

1. All bits in the Status Register except bits 4 and 5 are cleared, and bits 4 and 5 are set.
2. The Interrupt Enable, Interrupt Request, and Interrupt Service Registers are cleared. Pending requests and indications for interrupts in service will be cancelled. Interrupt signal INT will go low.
3. The receiver and transmitter are reset. The transmitter goes idle (TxD is high), and the receiver enters start bit search mode.
4. If Port 2 is programmed for handshake mode, IBF and OBF are reset high.

RST does *not* alter ports, data registers or command registers, but it halts any operation in progress. RST is automatically cleared.

RST = 0 has no effect. The reset operation triggered by Command Register 3 is a subset of the hardware reset.

TBRK—TRANSMIT BREAK

The transmission data output TxD will be set low as soon as the transmission of the previous character has been finished. It stays low until TBRK is cleared. The state of \overline{CTS} is of no significance for this operation. As long as break is active, data transfer from the Transmitter Buffer to the Transmitter Register will be inhibited. As soon as TBRK is reset, the break condition will be deactivated and the transmitter will be re-enabled.

SBRK—SINGLE CHARACTER BREAK

This causes the transmitter data to be set low for one character including start bit, data bits, parity bit, and stop bits. SBRK is automatically cleared when time for the last data bit has passed. It will start after the character in progress completes, and will delay the next data transfer from the Transmitter Buffer to the Transmitter Register until TxD returns to an idle (marking) state. If both TBRK and SBRK are set, break will be set as long as TBRK is set, but SBRK will be cleared after one character time of break. If SBRK is set again, it remains set for another character. The user can send a definite number of break characters in this manner by clearing TBRK after setting SBRK for the last character time.

END—END OF INTERRUPT

If fully nested interrupt mode is selected, this bit resets the currently served interrupt level in the Interrupt Service Register. *This command must occur at the end of each interrupt service routine during fully nested interrupt mode.* END is automatically cleared when the Interrupt Service Register (internal) is cleared. END is ignored if nested interrupts are not enabled.

NIE—NESTED INTERRUPT ENABLE

When NIE equals 1, the interrupt controller will operate in the nested interrupt mode. When NIE equals 0, the interrupt controller will operate in the normal interrupt mode. Refer to the "Interrupt controller" section of AP-153 under "Normal Mode" and "Nested Mode" for a detailed description of these operations.

IAE—INTERRUPT ACKNOWLEDGE ENABLE

This bit enables an automatic response to \overline{INTA} . The particular response is determined by the 8086 bit in Command Register 1.

RxE—RECEIVE ENABLE

This bit enables the serial receiver and its associated status bits in the status register. If this bit is reset, the serial receiver will be disabled and the receive status bits will not be updated.

Note that the detection of break characters remains enabled while the receiver is disabled; i.e., Status Register Bit 3 (BD) will be set while the receiver is disabled whenever a break character has been recognized at the receive data input RxD.

SET—BIT SET/RESET

If this bit is high during a write to Command Register 3, then any bit marked by a high will set. If this bit is low, then any bit marked by a high will be cleared.

MODE REGISTER

T35	T24	T5C	CT3	CT2	P2C2	P2C1	P2C0
(3R)			(3W)				

If test mode is selected, the output from the internal baud rate generator is placed on bit 4 of Port 1 (pin 35).

To achieve this, it is necessary to program bit 4 of Port 1 as an output (Port 1 Control Register Bit P14 = 1), and to program Command Register 2 bits B3–B0 with a value $\geq 3H$.

P2C2, P2C1, P2C0—PORT 2 CONTROL

P2C2	P2C1	P2C0	Mode	Direction	
				Upper	Lower
0	0	0	Nibble	Input	Input
0	0	1	Nibble	Input	Output
0	1	0	Nibble	Output	Input
0	1	1	Nibble	Output	Output
1	0	0	Byte Handshake	Input	
1	0	1	Byte Handshake	Output	
1	1	0	DO NOT USE		
1	1	1	Test		

NOTE:

If Port 2 is operating in handshake mode, Interrupt Level 7 is not available for Timer 5. Instead it is assigned to Port 2 handshaking.

3

CT2, CT3—COUNTER/TIMER MODE

Bit 3 and 4 defines the mode of operation of event counter/timers 2 and 3 regardless of its use as a single unit or as a cascaded one.

If CT2 or CT3 are high, then counter/timer 2 or 3 respectively is configured as an event counter on bit 2 or 3 respectively of Port 1 (pins 37 or 36). The event counter decrements the count by one on each low-to-high transition of the external input. If CT2 or CT3 is low, then the respective counter/timer is configured as a timer and the Port 1 pins are used for parallel I/O.

T5C—TIMER 5 CONTROL

If T5C is set, then Timer 5 can be preset and started by an external signal. Writing to the Timer 5 register loads the Timer 5 save register and stops the timer. A high-to-low transition on bit 5 of Port 1 (pin 34) loads the timer with the saved value and starts the timer. The next high-to-low transition on pin 34 re-triggers the timer by reloading it with the initial value and continues timing.

Following a hardware reset, the save register is reset to 00H and both clock and trigger inputs are disabled. Transferring an instruction with T5C = 1 enables the trigger input; the save register can now be loaded with an initial value. The first trigger pulse causes the initial value to be loaded from the save register and enables the counter to count down to zero.

When the timer reaches zero it issues an interrupt request, disables its interrupt level and continues

counting. A subsequent high-to-low transition on pin 5 resets Timer 5 to its initial value. For another timer interrupt, the Timer 5 interrupt enable bit must be set again.

T35, T24—CASCADE TIMERS

These two bits cascade Timers 3 and 5 or 2 and 4.

Timers 2 and 3 are the lower bytes, while Timers 4 and 5 are the upper bytes. If T5C is set, then both Timers 3 and 5 can be preset and started by an external pulse.

When a high-to-low transition occurs, Timer 5 is preset to its saved value, but Timer 3 is always preset to all ones. If either CT2 or CT3 is set, then the corresponding timer pair is a 16-bit event counter.

A summary of the counter/timer control bits is given in Table 3.

NOTE:

Interrupt levels assigned to single counters are partly not occupied if event counters/timers are cascaded. Level 2 will be vacated if event counters/timers 2 and 4 are cascaded. Likewise, Level 7 will be vacated if event counters/timers 3 and 5 are cascaded.

Single event counters/timers generate an interrupt request on the transition from 01H to 00H, while cascaded ones generate it on the transition from 0001H to 0000H.

Port 1 Control Register

P17	P16	P15	P14	P13	P12	P11	P10
(4R)				(4W)			

Each bit in the Port 1 Control Register configures the direction of the corresponding pin. If the bit is high, the pin is an output, and if it is low the pin is an input. Every Port 1 pin has another function which is controlled by other registers. If that special function is disabled, the pin functions as a general I/O pin as specified by this register. The special functions for each pin are described below.

Port 10, 11—HANDSHAKE CONTROL

If byte handshake control is enabled for Port 2 by the Mode Register, then Port 10 is programmed as STB/ACK handshake control input, and Port 11 is programmed as IBF/OBF handshake control output.

If byte handshake mode is enabled for output on Port 2 OBF indicates that a character has been loaded into the Port 2 output buffer. When an external

Table 3. Event Counters/Timers Mode of Operation

Event Counter/Timer	Function	Programming (Mode Word)	Clock Source
1	8-bit timer	—	Internal clock
2	8-bit timer	T24 = 0, CT2 = 0	Internal clock
	8-bit event counter	T24 = 0, CT2 = 1	P12 pin 37
2	8-bit timer	T35 = 0, CT3 = 0	Internal clock
	8-bit event counter	T35 = 0, CT3 = 1	P13 pin 36
4	8-bit timer	T24 = 0	Internal clock
5	8-bit timer, normal mode	T35 = 0, T5C = 0	Internal clock
	8-bit timer, retriggerable mode	T35 = 0, T5C = 1	Internal clock
2 and 4 cascaded	16-bit timer	T24 = 1, CT2 = 0	Internal clock
	16-bit event counter	T24 = 1, CT2 = 1	P12 pin 37
3 and 5 cascaded	16-bit timer, normal mode	T35 = 1, T5C = 0, CT3 = 0	Internal clock
	16-bit event counter, normal mode	T35 = 1, T5C = 0, CT3 = 1	P13 pin 36
	16-bit timer, retriggerable mode	T35 = 1, T5C = 1, CT3 = 0	Internal clock
	16-bit event counter, retriggerable mode	T35 = 1, T5C = 1, CT3 = 1	P13 pin 36

device reads the data, it acknowledges this operation by driving \overline{ACK} low. \overline{OBF} is set low by writing to Port 2 and is reset by \overline{ACK} .

If byte handshake mode is enabled for input on Port 2, \overline{STB} is an input. \overline{IBF} is driven low after \overline{STB} goes low. On the rising edge of \overline{STB} the data from Port 2 is latched.

\overline{IBF} is reset high when Port 2 is read.

PORT 12, 13—COUNTER 2, 3 INPUT

If Timer 2 or Timer 3 is programmed as an event counter by the Mode Register, then Port 12 or Port 13 is the counter input for Event Counter 2 or 3, respectively.

PORT 14—BAUD RATE GENERATOR OUTPUT CLOCK

If test mode is enabled by the Mode Register and Command Register 2 baud rate select is greater than 2, then Port 14 is an output from the internal baud rate generator.

P14 in Port 1 control register must be set to 1 for the baud rate generator clock to be output. The baud rate generator clock is $64 \times$ the serial bit rate except at 19.2 Kbps when it is $32 \times$ the bit rate.

PORT 15—TIMER 5 TRIGGER

If T5C is set in the Mode Register enabling a retriggerable timer, then Port 15 is the input which starts and reloads Timer 5.

A high-to-low transition on P15 (Pin 34) loads the timer with the slave register and starts the timer.

PORT 16—BREAK-IN DETECT

If Break-In Detect is enabled by BRKI in Command Register 1, then this input is used to sense a Break-In. If Port 16 is low while the serial transmitter is sending the last stop bit, then a Break-In condition is signaled.

PORT 17—PORT INTERRUPT SOURCE

If BITI in Command Register 1 is set, then a low-to-high transition on Port 17 generates an interrupt request on Priority Level 1.

Port 17 is edge triggered.

Interrupt Enable Register

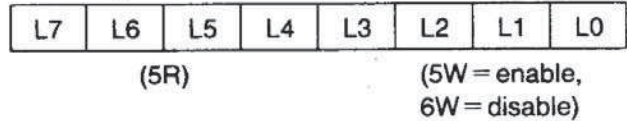

Interrupts are enabled by writing to the Set Interrupts Register (5W). Interrupts are disabled by writing to the Reset Interrupts Register (6W). Each bit set by the Set Interrupts Register (5W) will enable that level interrupt, and each bit set in the Reset Interrupts Register (6W) will disable that level interrupt. The user can determine which interrupts are enabled by reading the Interrupt Enable Register (5R).

Priority	Source
Highest	L0 Timer 1
	L1 Timer 2 or Port Interrupt
	L2 External Interrupt (EXTINT)
	L3 Timer 3 or Timers 3 & 5
	L4 Receive Interrupt
	L5 Transmitter Interrupt
	L6 Timer 4 or Timers 2 & 4
Lowest	L7 Timer 5 or Port 2 Handshaking

3

Interrupt Address Register

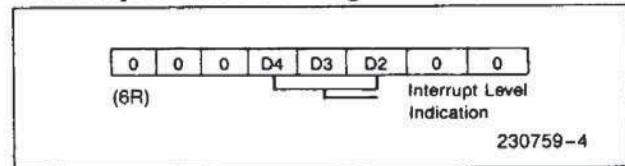

Reading the interrupt address register transfers an identifier for the currently requested interrupt level on the system data bus. This identifier is the number of the interrupt level multiplied by 4. It can be used by the CPU as an offset address for interrupt handling. Reading the interrupt address register has the same effect as a hardware interrupt acknowledge INTA; it clears the interrupt request pin (INT) and indicates an interrupt acknowledgement to the interrupt controller.

Receiver and Transmitter Buffer

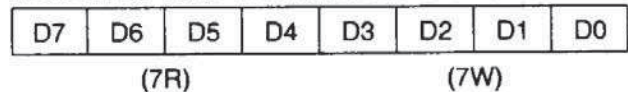

Both the receiver and transmitter in the MUART are double buffered. This means that the transmitter and receiver have a shift register and a buffer register. The buffer registers are directly addressable by reading or writing to register seven. After the receiver buffer is full, the RBF bit in the status register is set.

Reading the receive buffer clears the RBF status bit. The transmit buffer should be written to only if the TBE bit in the status register is set. Bytes written to the transmit buffer are held there until the transmit shift register is empty, assuming \overline{CTS} is low. If the transmit buffer and shift register are empty, writing to the transmit buffer immediately transfers the byte to the transmit shift register. If a serial character length is less than 8 bits, the unused most significant bits are set to zero when reading the receive buffer, and are ignored when writing to the transmit buffer.

Port 1

D7	D6	D5	D4	D3	D2	D1	D0
(8R)				(8W)			

Writing to Port 1 sets the data in the Port 1 output latch. Writing to an input pin does not affect the pin, but the data is stored and will be output if the direction of the pin is changed later. If the pin is used as a control signal, the pin will not be affected, but the data is stored. Reading Port 1 transfers the data in Port 1 onto the data bus.

Port 2

D7	D6	D5	D4	D3	D2	D1	D0
(9R)				(9W)			

Writing to Port 2 sets the data in the Port 2 output latch. Writing to an input pin does not affect the pin, but it does store the data in the latch. Reading Port 2 puts the input pins onto the bus or the contents of the output latch for output pins.

Timer 1-5

D7	D6	D5	D4	D3	D2	D1	D0
(0A ₁₆ -OE ₁₆ R)				(0A ₁₆ -OE ₁₆ W)			

Reading Timer N puts the contents of the timer onto the data bus. If the counter changes while \overline{RD} is low, the value on the data bus will not change. If two timers are cascaded, reading the high-order byte will cause the low-order byte to be latched. Reading the low-order byte will unlatch them both. Writing to either timer or decascading them also clears the latch condition. Writing to a timer sets the starting value of that timer. If two timers are cascaded, writing to the high-order byte presets the low-order byte to all ones. Loading only the high-order byte with a value of X leads to a count of $X * 256 + 255$. Timers count down continuously. If the interrupt is enabled, it occurs when the counter changes from 1 to 0.

The timer/counter interrupts are automatically disabled when the interrupt request is generated.

Status Register

INT	RBF	TBE	TRE	BD	PE	OE	FE
(0F ₁₆ R)							

Reading the status register gates its contents onto the data bus. It holds the operational status of the serial interface as well as the status of the interrupt in INT. The status register can be read at any time. The flags are stable and well defined at all instants.

FE—FRAMING ERROR, TRANSMISSION MODE

Bit 0 can be used in two modes. Normally, FE indicates framing error which can be changed to transmission mode indication by setting the TME bit in the modification register.

If transmission mode is disabled (in Modification Register), then FE indicates a framing error. A framing error is detected during the *first* stop bit. The error is reset by reading the Status Register or by a chip reset. A framing error does not inhibit the loading of the Receiver Buffer. If RxD remains low, the receiver will assemble the next character. The false stop bit is treated as the next start bit, and no high-to-low transition on RxD is required to synchronize the receiver.

When the TME bit in the Modification Register is set, FE is used to indicate that the transmitter was active during the reception of a character, thus indicating that the character received was transmitted by its own transmitter. FE is reset when the transmitter is not active during the reception of character. Reading the status register will not reset the FE bit in the transmission mode.

OE—OVERRUN ERROR

If the user does not read the character in the Receiver Buffer before the next character is received and transferred to this register, then the OE bit is set. The OE flag is set during the reception of the first stop bit and is cleared when the Status Register is read or when a hardware or software reset occurs. The first character received in this case will be lost.

PE—PARITY ERROR

This bit indicates a parity error has occurred during the reception of a character. A parity error is present

if value of the parity bit in the received character is different from the one expected according to command word 2 bits 6 EP. The parity bit is expected and checked only if it is enabled by command word 2 bit 7 PEN.

A parity error is set during the first stop bit and is reset by reading the Status Register or by a chip reset.

BD—BREAK/BREAK-IN

The BD bit flags whether a break character has been received, or a Break-In condition exists on the transmission line. Command Register 1 Bit 3 (BRKI) enables the Break-In Detect function.

Whenever a break character has been received, Status Register Bit 3 will be set and in addition an interrupt request on Level 4 is generated. The receiver will be idled. It will be started again with the next high-to-low transition at pin RxD.

The break character received will not be loaded into the receiver buffer register.

If Break-In Detection is enabled and a Break-In condition occurs, Status Register Bit 3 will be set and in addition an interrupt request on Level 5 is generated.

The BD status bit will be reset on reading the status register or on a hardware or software reset. For more information on Break/Break-In, refer to the "Serial Asynchronous Communication" section of AP-153 under "Receive Break Detect" and "Break-In Detect."

TRE—TRANSMIT REGISTER EMPTY

When TRE is set the transmit register is empty and an interrupt request is generated on Level 5 if enabled. When TRE equals 0 the transmit register is in the process of sending data. TRE is set by a chip reset and when the last stop bit has left the transmitter. It is reset when a character is loaded into the Transmitter Register. If \overline{CTS} is low, the Transmitter Register will be loaded during the transmission of the start bit. If \overline{CTS} is high at the end of a character, TRE will remain high and no character will be loaded into the Transmitter Register until \overline{CTS} goes low. If the transmitter was inactive before a character is loaded into the Transmitter Buffer, the Transmitter Register will be empty temporarily while the buffer is full. However, the data in the buffer will be transferred to the transmitter register immediately and TRE will be cleared while TBE is set.

TBE—TRANSMITTER BUFFER EMPTY

TBE indicates the Transmitter Buffer is empty and is ready to accept a character. TBE is set by a chip reset or the transfer of data to the Transmitter Register, and is cleared when a character is written to the transmitter buffer. When TBE is set, an interrupt request is generated on Level 5 if enabled.

RBF—RECEIVER BUFFER FULL

RBF is set when the Receiver Buffer has been loaded with a new character during the sampling of the first stop bit. RBF is cleared by reading the receiver buffer or by a chip reset.

INT—INTERRUPT PENDING

The INT bit reflects the state of the INT Pin (Pin 15) and indicates an interrupt is pending. It is reset by \overline{INTA} or by reading the Interrupt Address Register if only one interrupt is pending and by a chip reset.

FE, OE, PE, RBF, and Break Detect all generate a Level 4 interrupt when the receiver samples the first stop bit. TRE, TBE, and Break-In Detect generate a Level 5 interrupt. TRE generates an interrupt when TBE is set and the Transmitter Register finished transmitting. The Break-In Detect interrupt is issued at the same time as TBE or TRE.

MODIFICATION REGISTER

0	RS4	RS3	RS2	RS1	RS0	TME	DSC
---	-----	-----	-----	-----	-----	-----	-----

(0F₁₆W)

DSC—DISABLE START BIT CHECK

DSC disables the receivers start bit check. In this state the receiver will not be reset if RxD is not low at the center of the start bit.

TME—TRANSMISSION MODE ENABLE

TME enables transmission mode and disables framing error detection. For information on transmission mode see the description of the framing error bit in the status register.

RS0, RS1, RS2, RS3, RS4—RECEIVER SAMPLE TIME

The number in RS_n alters when the receiver samples RxD. The receiver sample time can be modified only if the receiver is *not* clocked by RxC.

NOTE:

The modification register cannot be read. Reading from address 0FH, 8086: 1EH gates the contents of the status register onto the data bus.

A hardware reset (reset, Pin 12) resets all modification register bits to 0, i.e.:

- The start bit check is enabled.
- Status Register Bit 0 (FE) indicates framing error.
- The sampling time of the serial receiver is the bit center.

A software reset (Command Word 3, RST) does not affect the modification register.

Hardware Reset

A reset signal on pin RESET (HIGH level) forces the device 8256 into a well-defined initial state. This state is characterized as follows:

- 1) Command registers 1, 2 and 3, mode register, Port 1 control register, and modification register are reset. Thus, all bits of the parallel interface are set to be inputs and event counters/timers are configured as independent 8-bit timers.
- 2) Status register bits are reset with the exception of bits 4 and 5. Bits 4 and 5 are set indicating that both transmitter register and transmitter buffer register are empty.
- 3) The interrupt mask, interrupt request, and interrupt service register bits are reset and disable all requests. As a consequence, interrupt signal INT IS INACTIVE (LOW).
- 4) The transmit data output is set to the marking state (HIGH) and the receiver section is disabled until it is enabled by Command Register 3 Bit 6.
- 5) The start bit will be checked at sampling time. The receiver will return to start bit search mode if input RxD is not LOW at this time.
- 6) Status Register Bit 0 implies framing error.
- 7) The receiver samples input RxD at bit center.

Reset has no effect on the contents of receiver buffer register, transmitter buffer register, the intermediate latches of parallel ports, and event counters/timers, respectively.

RS4	RS3	RS2	RS1	RS0	Point of Time Between Start of Bit and End of Bit Measured in Steps of 1/32 Bit Length
0	1	1	1	1	1 (Start of Bit)
0	1	1	1	0	2
0	1	1	0	1	3
0	1	1	0	0	4
0	1	0	1	1	5
0	1	0	1	0	6
0	1	0	0	1	7
0	1	0	0	0	8
0	0	1	1	1	9
0	0	1	1	0	10
0	0	1	0	1	11
0	0	1	0	0	12
0	0	0	1	1	13
0	0	0	1	0	14
0	0	0	0	1	15
0	0	0	0	0	16 (Bit center)
1	1	1	1	1	17
1	1	1	1	0	18
1	1	1	0	1	19
1	1	1	0	0	20
1	1	0	1	1	21
1	1	0	1	0	22
1	1	0	0	1	23
1	1	0	0	0	24
1	0	1	1	1	25
1	0	1	1	0	26
1	0	1	0	1	27
1	0	1	0	0	28
1	0	0	1	1	29
1	0	0	1	0	30
1	0	0	0	1	31
1	0	0	0	0	32 (End of Bit)

ABSOLUTE MAXIMUM RATINGS*

Ambient Temperature Under Bias 0°C to 70°C
 Storage Temperature -65°C to +150°C
 Voltage On Any Pin
 with Respect to Ground -0.5V to +7V
 Power Dissipation 1W

NOTICE: This is a production data sheet. The specifications are subject to change without notice.

**WARNING: Stressing the device beyond the "Absolute Maximum Ratings" may cause permanent damage. These are stress ratings only. Operation beyond the "Operating Conditions" is not recommended and extended exposure beyond the "Operating Conditions" may affect device reliability.*

D.C. CHARACTERISTICS $T_A = 0^\circ\text{C to } 70^\circ\text{C}, V_{CC} = +5.0\text{V} \pm 10\%$

Symbol	Parameter	Min	Max	Units	Test Conditions
V_{IL}	Input Low Voltage	-0.5	0.8	V	
V_{IH}	Input High Voltage	2.0	$V_{CC} + 0.5$	V	
V_{OL}	Output Low Voltage		0.45	V	$I_{OL} = 2.5\text{ mA}$
V_{OH}	Output High Voltage	2.4		V	$I_{OH} = -400\ \mu\text{A}$
I_{IL}	Input Leakage		10 -10	μA μA	$V_{IN} = V_{CC}$ $V_{IN} = 0\text{V}$
I_{LO}	Output Leakage		10 -10	μA μA	$V_{OUT} = V_{CC}$ $V_{OUT} = 0.45\text{V}$
I_{CC}	V_{CC} Supply Current		160	mA	
C_{IN}	Input Capacitance		10	pF	$f_c = 1\text{ MHz}^{(1)}$
$C_{I/O}$	I/O Capacitance		20	pF	Unmeasured Pins Returned to $V_{SS}^{(1)}$

NOTE:

1. Sampled, not 100% tested. $T_A = 25^\circ\text{C}$.

A.C. CHARACTERISTICS $T_A = 0^\circ\text{C to } 70^\circ\text{C}, V_{CC} = +5.0\text{V} \pm 10\%, \text{GND} = 0\text{V}$

Symbol	Parameter	8256AH		Units
		Min	Max	
BUS PARAMETERS				
t_{LL}	ALE Pulse Width	50		ns
t_{CSL}	\overline{CS} to ALE Setup Time	0		ns
t_{AL}	Address to ALE Setup Time	20		ns
t_{LA}	Address Hold Time after ALE	25		ns
t_{LC}	ALE to $\overline{RD}/\overline{WR}$	20		ns
t_{CC}	$\overline{RD}, \overline{WR}, \overline{INTA}$ Pulse Width	200		ns
t_{RD}	Data Valid from $\overline{RD}^{(1)}$		120	ns

3

A.C. CHARACTERISTICS $T_A = 0^\circ\text{C to }70^\circ\text{C}$, $V_{CC} = +5.0\text{V} \pm 10\%$, $\text{GND} = 0\text{V}$ (Continued)

Symbol	Parameter	8256AH		Units
		Min	Max	
BUS PARAMETERS (Continued)				
t_{DF}	Data Float after \overline{RD} (2)		50	ns
t_{DW}	Data Valid to \overline{WR}	150		ns
t_{WD}	Data Valid after \overline{WR}	50		ns
t_{CL}	$\overline{RD}/\overline{WR}$ Control to Latch Enable	25		ns
t_{LDR}	ALE to Data Valid		150	ns
t_{RST}	Reset Pulse Width	300		ns
t_{RV}	Recovery Time between $\overline{RD}/\overline{WR}$	500		ns
TIMER/COUNTER PARAMETERS				
t_{CPI}	Counter Input Cycle Time (P12, P13)	2.2		μs
t_{CPWH}	Counter Input Pulse Width High	1.1		μs
t_{CPWL}	Counter Input Pulse Width Low	1.1		μs
t_{TPI}	Counter Input \uparrow to INT \uparrow at Terminal Count		2.75	μs
t_{TIH}	LOAD Pulse High Time Counter 5	1.1		μs
t_{TIL}	LOAD Pulse Low Time Counter 5	1.1		μs
t_{PP}	Counter 5 Load before Next Clock Pulse on P13	1.1		μs
t_{CR}	External Count Clock \uparrow to \overline{RD} \downarrow to Ensure Clock is Reflected in Count	2.2		μs
t_{RC}	\overline{RD} \uparrow to External Count Clock \uparrow to Ensure Clock is not Reflected in Count	0		ns
t_{CW}	External Count Clock \uparrow to \overline{WR} \uparrow to Ensure Count Written is Not Decrement	2.2		μs
t_{WC}	\overline{WR} \uparrow to External Count Clock to Ensure Count Written is Decrement	0		ns
INTERRUPT PARAMETERS				
t_{DEX}	EXTINT \uparrow to INT \uparrow		200	ns
t_{DPI}	Interrupt Request on P17 \uparrow to INT \uparrow		$2t_{CY} + 500$	ns
t_{PI}	Pulse Width of Interrupt Request on P17	$t_{CY} + 100$		ns
t_{HEA}	\overline{INTA} \uparrow or \overline{RD} \uparrow to EXTINT \downarrow	30		ns
t_{HIA}	\overline{INTA} \uparrow or \overline{RD} \uparrow to INT \downarrow		300	μs
SERIAL INTERFACE AND CLOCK PARAMETERS				
t_{CY}	Clock Period	195	1000	ns
t_{CLKH}	Clock High Pulse Width	65		ns
t_{CLKL}	Clock Low Pulse Width	65		ns
t_R	Clock Rise Time		20	ns
t_F	Clock Fall Time		20	ns

A.C. CHARACTERISTICS $T_A = 0^\circ\text{C to } 70^\circ\text{C}$, $V_{CC} = +5.0\text{V} \pm 10\%$, $GND = 0\text{V}$ (Continued)

Symbol	Parameter	8256AH		Units
		Min	Max	
SERIAL INTERFACE AND CLOCK PARAMETERS (Continued)				
t_{SCY}	Serial Clock Period (4)	975		ns
t_{SPD}	Serial Clock High (4)	350		ns
t_{SPW}	Serial Clock Low (4)	350		ns
t_{STD}	Internal Status Update Delay from Center of Stop Bit (5)		300	ns
t_{DTX}	$\overline{\text{Tx}}\text{C}$ to TxD Data Valid		300	ns
t_{IRBF}	INT Delay from Center of First Stop Bit		$2t_{CY} + 500$	ns
t_{ITBE}	INT Delay from Falling Edge of Transmit Clock at End of Start Bit		$2t_{CY} + 500$	ns
t_{CTS}	Pulse Width for Single Character Transmission	(6)		
PARALLEL I/O PORT PARAMETERS				
t_{WP}	$\overline{\text{WR}} \uparrow$ to P1/P2 Data Valid		0	ns
t_{PR}	P1/P2 Data Stable before $\overline{\text{RD}} \downarrow$ (7)	300		ns
t_{RP}	P1/P2 Data Hold Time	50		ns
t_{AK}	$\overline{\text{ACK}}$ Pulse Width	150		ns
t_{ST}	Strobe Pulse Width	t_{SIB}		ns
t_{PS}	Data Setup to $\overline{\text{STB}} \uparrow$	50		ns
t_{PH}	Data Hold after $\overline{\text{STB}} \uparrow$	50		ns
t_{WOB}	$\overline{\text{WR}} \uparrow$ to $\overline{\text{OBF}} \uparrow$		250	ns
t_{AOB}	$\overline{\text{ACK}} \downarrow$ to $\overline{\text{OBF}} \downarrow$		250	ns
t_{SIB}	$\overline{\text{STB}} \downarrow$ to $\overline{\text{IBF}} \downarrow$		250	ns
t_{RI}	$\overline{\text{RD}} \uparrow$ to $\overline{\text{IBF}} \uparrow$		250	ns
t_{SIT}	$\overline{\text{STB}} \uparrow$ to $\overline{\text{INT}} \uparrow$		$2t_{CY} + 500$	ns
t_{AIT}	$\overline{\text{ACK}} \uparrow$ to $\overline{\text{INT}} \uparrow$		$2t_{CY} + 500$	ns
t_{AED}	$\overline{\text{OBF}} \downarrow$ to $\overline{\text{ACK}} \downarrow$ Delay	0		ns

3
NOTES:

- $C_L = \text{pF}$ all outputs.
- Measured from logic "one" or "zero" to 1.5V at $C_L = 150 \text{ pF}$.
- P12, P13 are external clock inputs.
- Note that RxC may be used as an input only in $1 \times$ mode, otherwise it will be an output.
- The center of the Stop Bit will be the receiver sample time, as programmed by the modification register.
- $\frac{1}{4}$ th bit length for $32 \times$, $64 \times$; 100 ns for $1 \times$.
- To ensure t_{PD} spec is met.

WAVEFORMS

A.C. TESTING INPUT, OUTPUT WAVEFORM

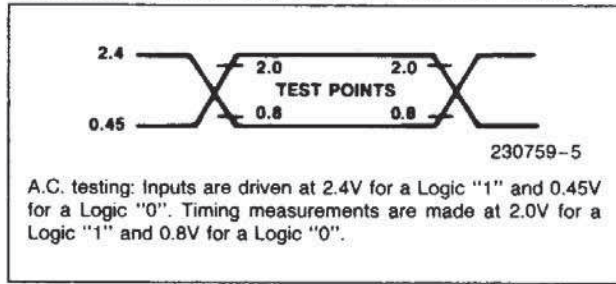

A.C. TESTING LOAD CIRCUIT

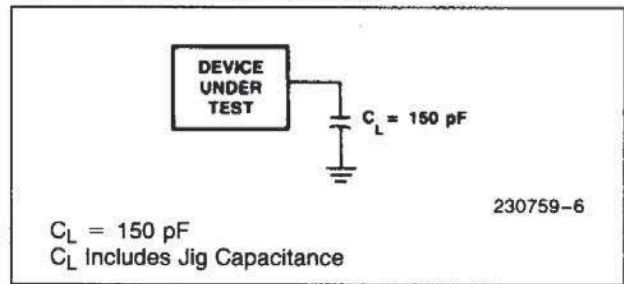

SYSTEM CLOCK

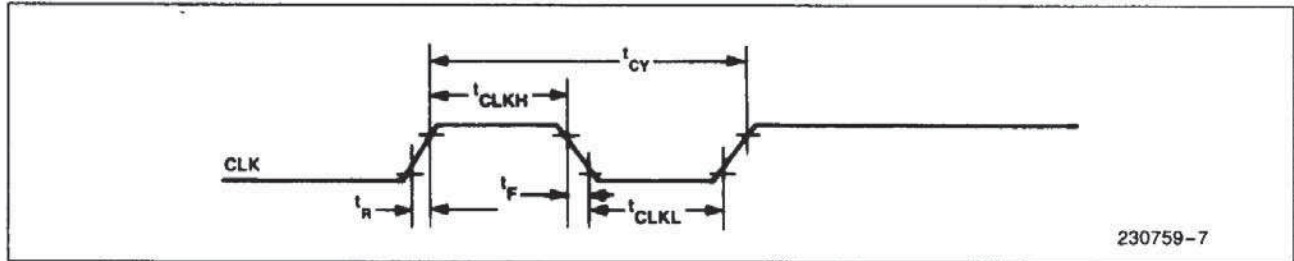

WRITE CYCLE

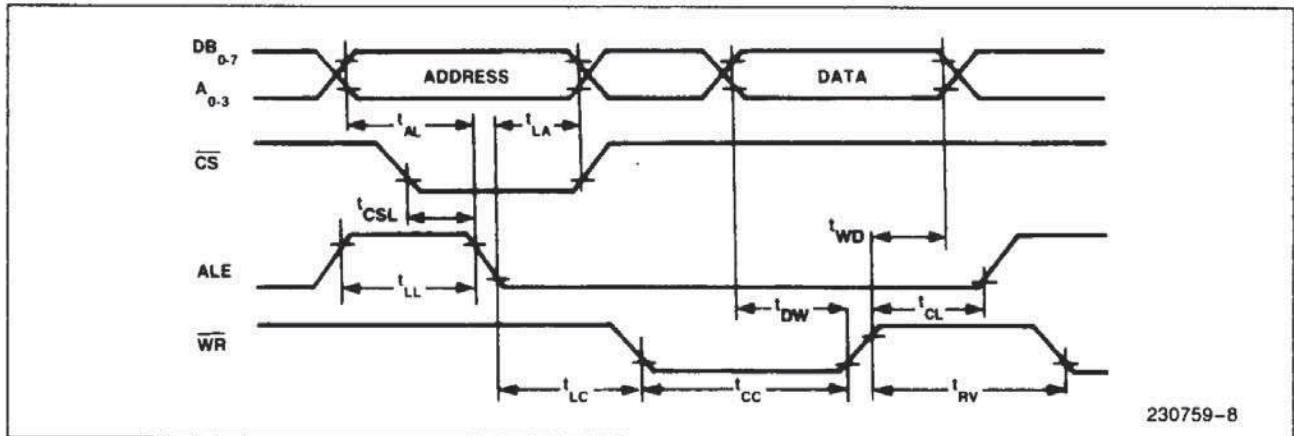

READ CYCLE

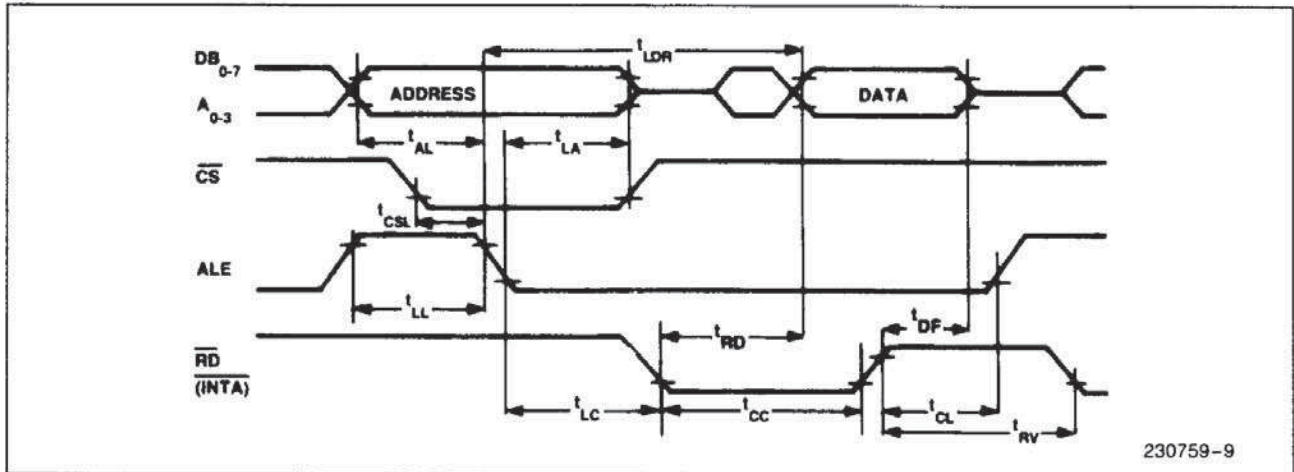

WAVEFORMS (Continued)

PARALLEL PORT HANDSHAKING—INPUT MODE

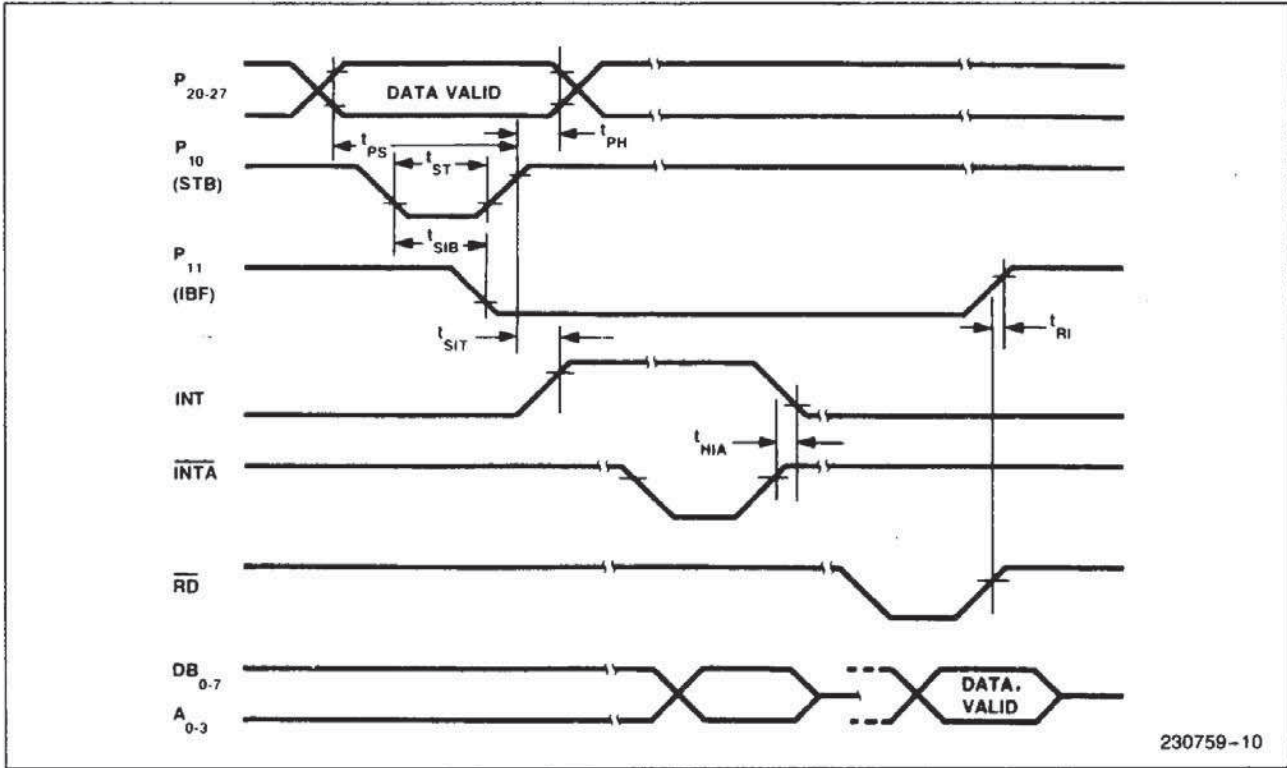

3

PARALLEL PORT HANDSHAKING—OUTPUT MODE

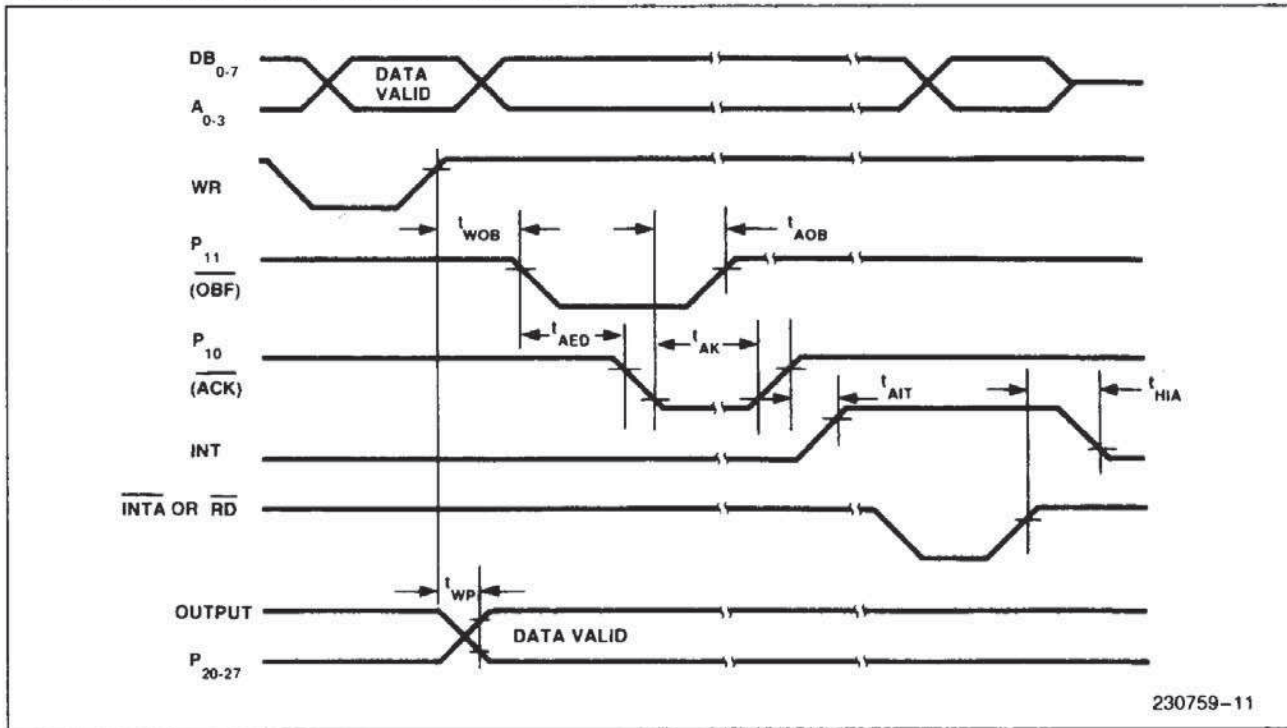

COUNT PULSE TIMINGS

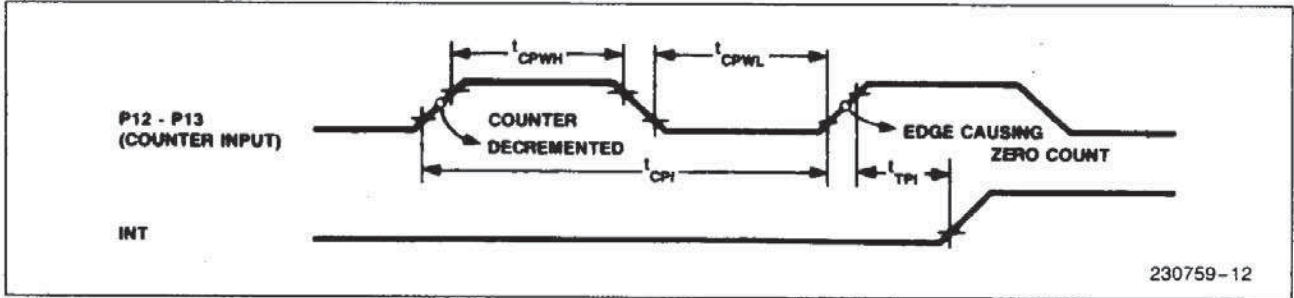

230759-12

LOADING TIMER (OR CASCADED COUNTER/TIMER 3 AND 5)

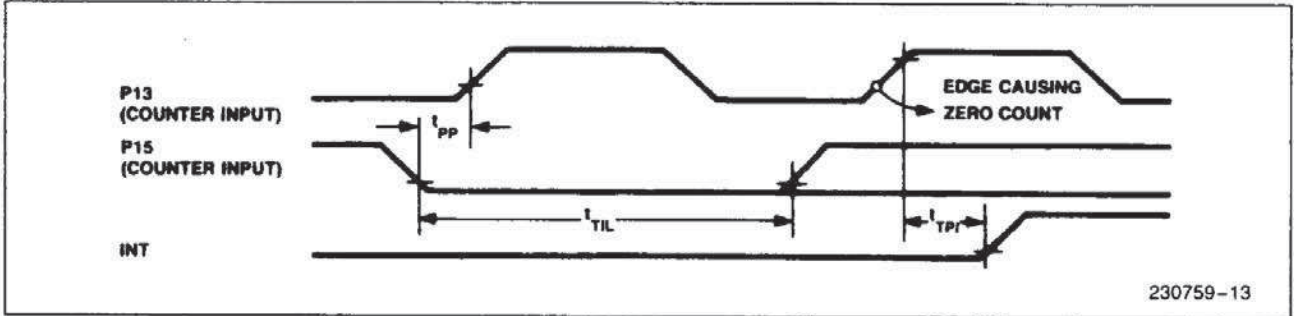

230759-13

TRIGGER PULSE FOR TIMER 5 (CASCADED EVENT COUNTER/TIMER 3 AND 5)

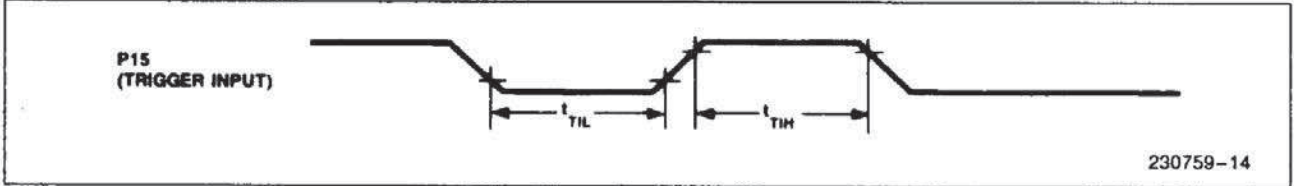

230759-14

COUNTER TIMER TIMING

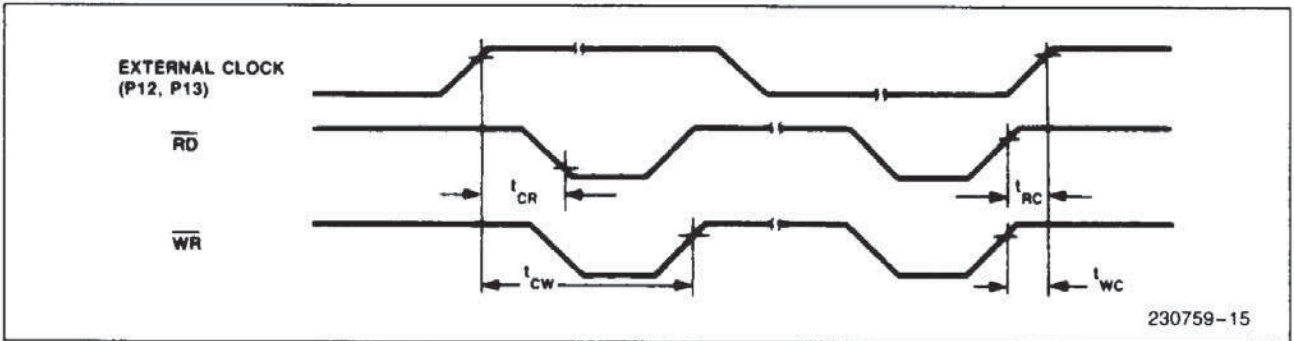

230759-15

OUTPUT FROM PORT 1 AND PORT 2

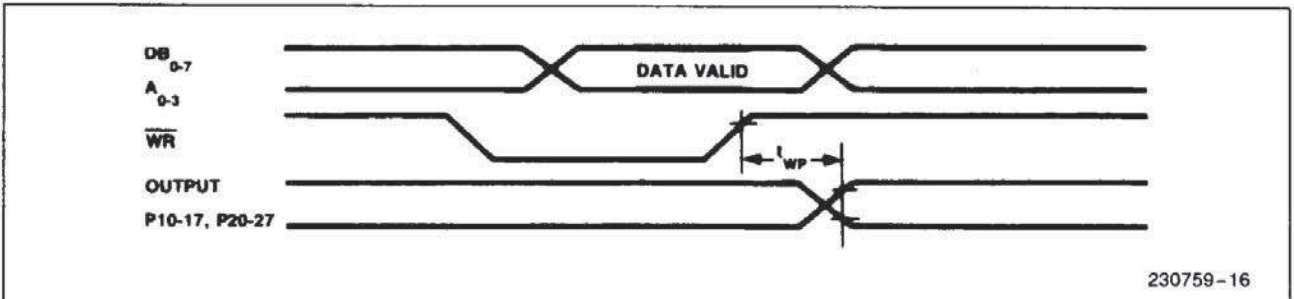

230759-16

INPUT FROM PORT 1 AND PORT 2

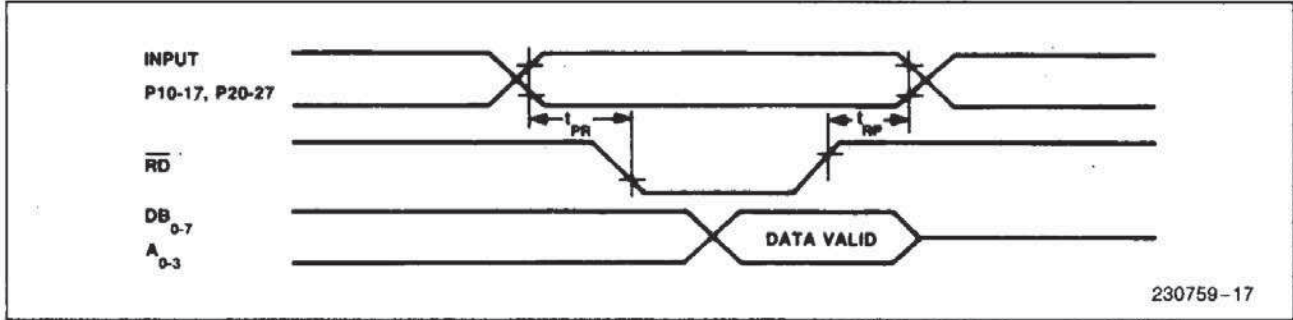

INTERRUPT TIMING

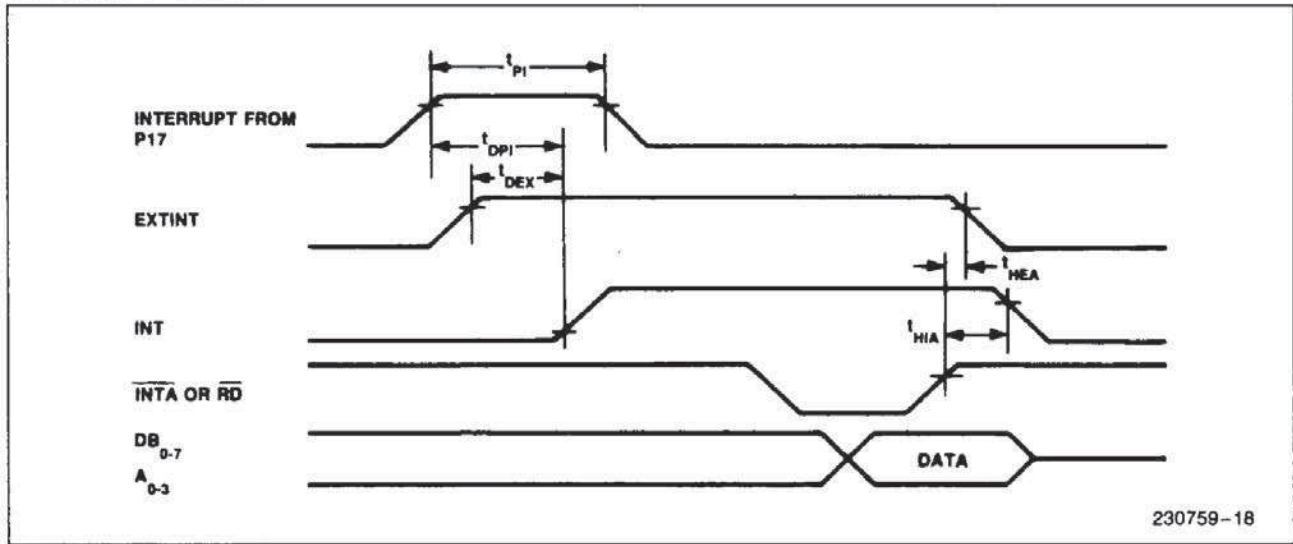

3

\overline{CTS} FOR SINGLE CHARACTER TRANSMISSION

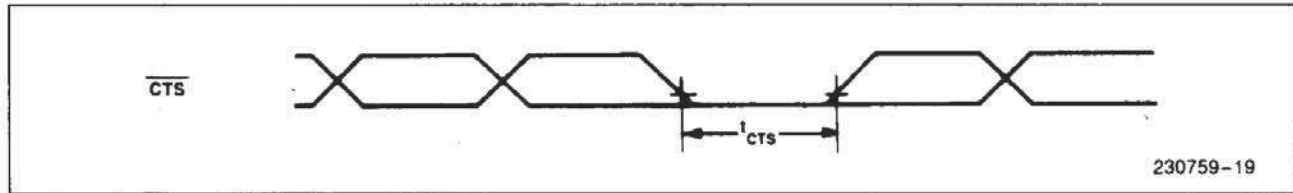

RESET TIMING

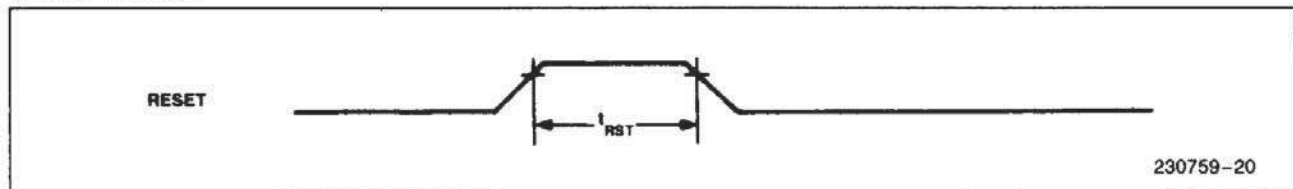

EXTERNAL BAUD RATE CLOCK FOR SERIAL INTERFACE

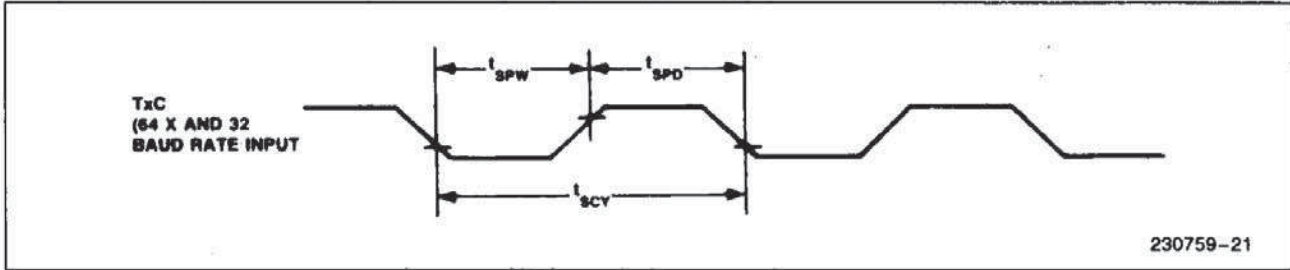

TRANSMITTER AND RECEIVER CLOCK FROM INTERNAL CLOCK SOURCE

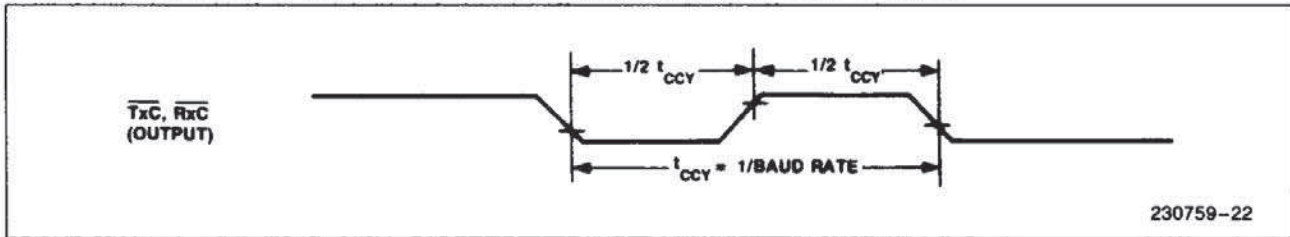

TRANSMISSION OF CHARACTERS ON SERIAL INTERFACE

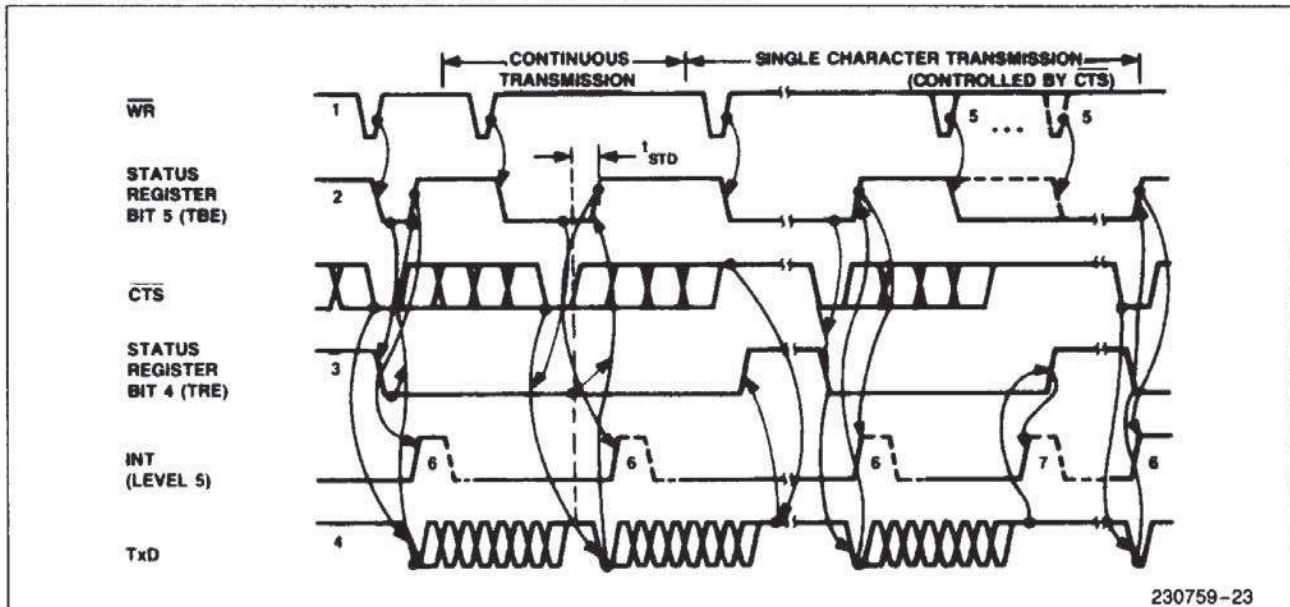

NOTES:

1. Load transmitter buffer register.
 2. Transmitter buffer register is empty.
 3. Transmitter register is empty.
 4. Character format for this example: 7 Data Bits with Parity Bit and 2 Stop Bits.
 5. Loading of transmitter buffer register must be complete before \overline{CTS} goes low.
 6. Interrupt due to transmitter buffer register empty.
 7. Interrupt due to transmitter register empty.
- No status bits are altered when \overline{RD} is active.

DATA BIT OUTPUT ON SERIAL INTERFACE

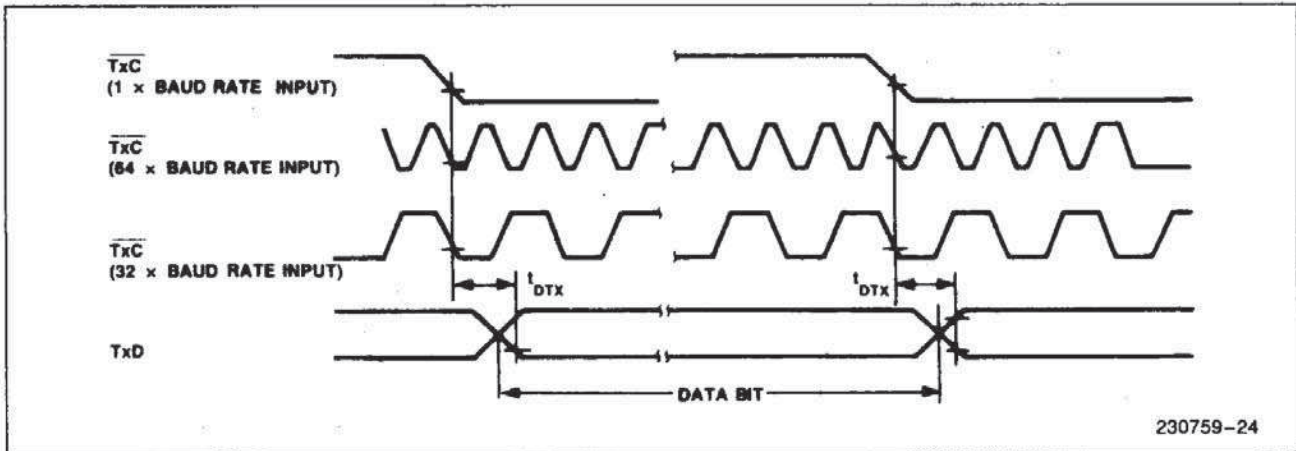

CONTINUOUS RECEPTION OF CHARACTERS ON SERIAL INTERFACE WITHOUT ERROR CONDITION

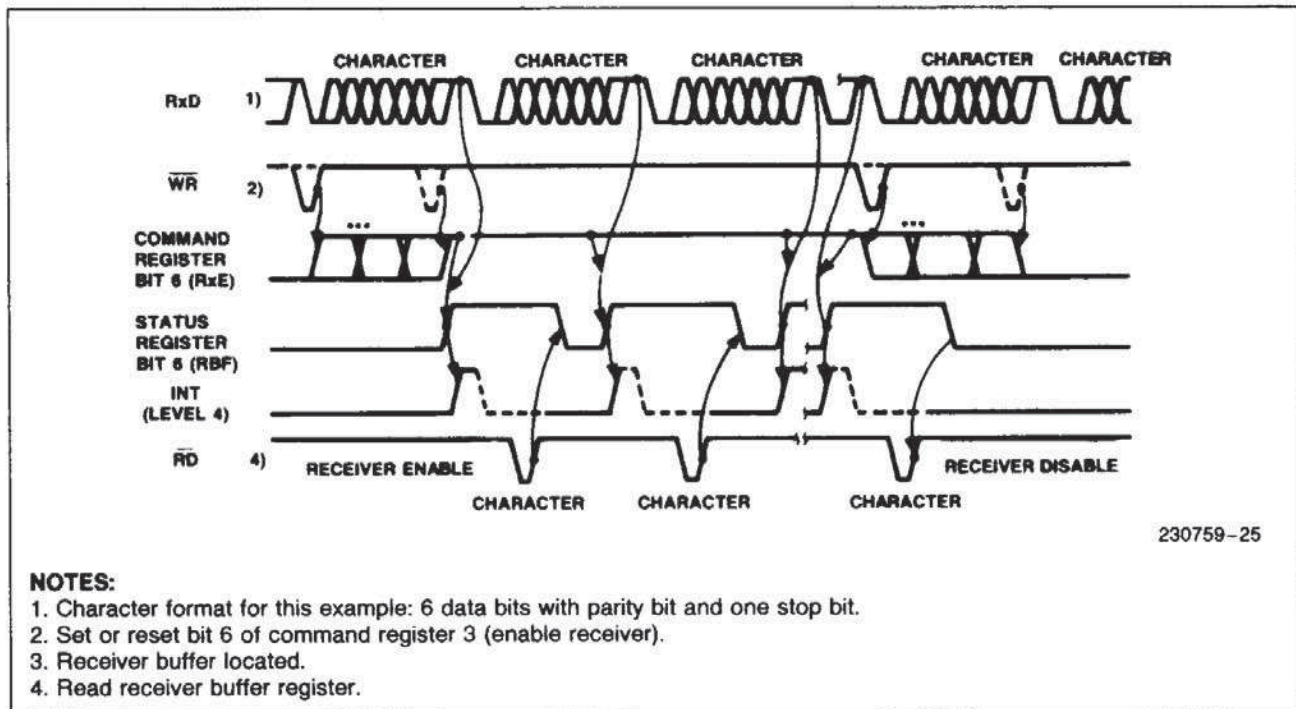

NOTES:

1. Character format for this example: 6 data bits with parity bit and one stop bit.
2. Set or reset bit 6 of command register 3 (enable receiver).
3. Receiver buffer located.
4. Read receiver buffer register.

3

ERROR CONDITIONS DURING RECEPTION OF CHARACTERS ON THE SERIAL INTERFACE

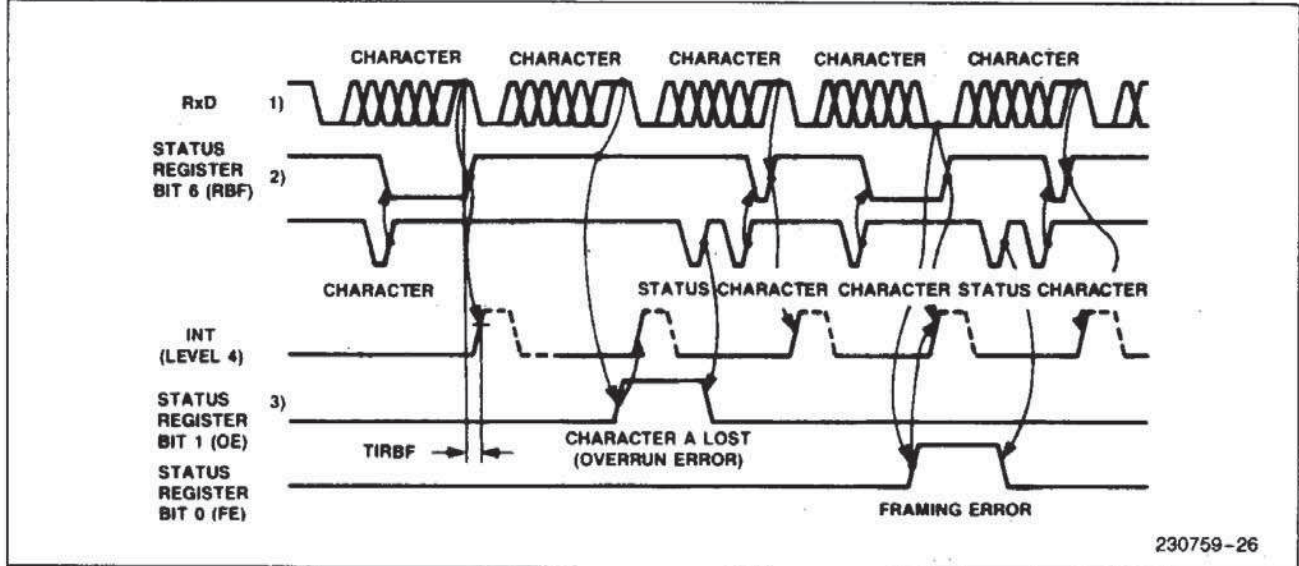
**NOTES:**

1. Character format for this example: 6 data bits without parity and one stop bit.
 2. Receiver buffer register loaded.
 3. Overrun error.
 4. Framing error.
 5. Interrupt from receiver buffer register loading.
 6. Interrupt from overrun error.
 7. Interrupt from framing error and loading receiver buffer register.
- No status bits are altered when \overline{RD} is active.