

AM25S557, AM25S558

Eight-Bit by Eight-Bit Combinatorial Multiplier

The AM25S557 and AM25S558 are high-speed, combinatorial, 8 x 8-bit multipliers. Both use an array of full adders to form and add partial products in a single unlocked operation, resulting in a 16-bit parallel output product.

Mode control inputs X_M and Y_M allow the multiplier to accept either unsigned or two's complement numbers from either respective input to provide an unsigned or signed output. The mode control lines are held LOW for unsigned input words and HIGH for two's complement.

Rochester Electronics Manufactured Components

Rochester branded components are manufactured using either die/wafers purchased from the original suppliers or Rochester wafers recreated from the original IP. All recreations are done with the approval of the OCM.

Parts are tested using original factory test programs or Rochester developed test solutions to guarantee product meets or exceeds the OCM data sheet.

Quality Overview

- ISO-9001
- AS9120 certification
- Qualified Manufacturers List (QML) MIL-PRF-38535
 - Class Q Military
 - Class V Space Level
- Qualified Suppliers List of Distributors (QSLD)
 - Rochester is a critical supplier to DLA and meets all industry and DLA standards.

Rochester Electronics, LLC is committed to supplying products that satisfy customer expectations for quality and are equal to those originally supplied by industry manufacturers.

The original manufacturer's datasheet accompanying this document reflects the performance and specifications of the Rochester manufactured version of this device. Rochester Electronics guarantees the performance of its semiconductor products to the original OEM specifications. 'Typical' values are for reference purposes only. Certain minimum or maximum ratings may be based on product characterization, design, simulation, or sample testing.

Am25S557/Am25S558

Eight-Bit by Eight-Bit Combinatorial Multiplier

DISTINCTIVE CHARACTERISTICS

- Multiplies two 8-bit numbers – 16-bit output
- Combinatorial – no clocks required
- Full 8 x 8 multiply in 45ns typ.
- Cascades to 16 x 16 in 110ns typ.
- Expandable to multiples of 8 bits
- MSB and $\overline{\text{MSB}}$ outputs for easy expansion
- Unsigned, two's complement or mixed operands
- Implements common rounding algorithms with additional logic
- Three-state outputs
- Transparent 16-bit latch in Am25S557
- Industry standard pin-outs

GENERAL DESCRIPTION

The Am25S557 and Am25S558 are high-speed, combinatorial, 8 x 8-bit multipliers. Both use an array of full adders to form and add partial products in a single unclocked operation, resulting in a 16-bit parallel output product.

Mode control inputs X_M and Y_M allow the multiplier to accept either unsigned or two's complement numbers from either respective input to provide an unsigned or signed output. The mode control lines are held LOW for unsigned input words and HIGH for two's complement.

The Am25S557 and Am25S558 are easily expandable to longer work lengths. Both S_{15} and \overline{S}_{15} are available to allow expansion in either signed or unsigned modes without external inverters. In the 16-bit by 16-bit configuration (32-bit output) the typical multiply time is 110ns.

Both configurations offer three-state output flexibility and the Am25S557 adds a 16-bit transparent latch between the multiplier array and the three-state output buffers (including \overline{S}_{15}).

Rounding provisions for 8-bit truncated output configurations are particularly optimized for maximum flexibility. The Am25S557 internally develops proper rounding for either signed or unsigned numbers by combining rounding input R with X_M , Y_M , \overline{X}_M and \overline{Y}_M as follows:

$R_U = \overline{X}_M \cdot \overline{Y}_M \cdot R =$ Unsigned Rounding input to 2^7 adder.

$R_S = (X_M + Y_M) R =$ Signed Rounding input to 2^6 adder.

Since the Am25S558 does not require the use of pin 9 for the latch enable input, (G), R_S and R_U are brought out separately.

BLOCK DIAGRAM

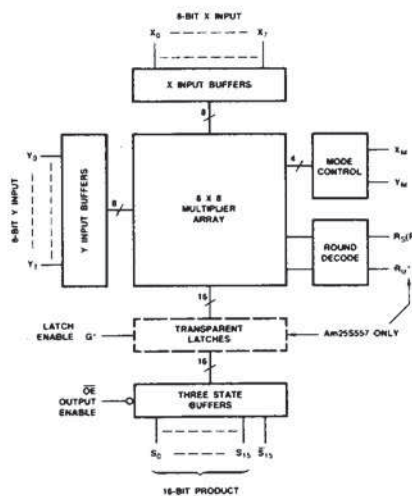

BD001780

*Pin 11 is G for Am25S557 and R_U for Am25S558.

CONNECTION DIAGRAM Top View

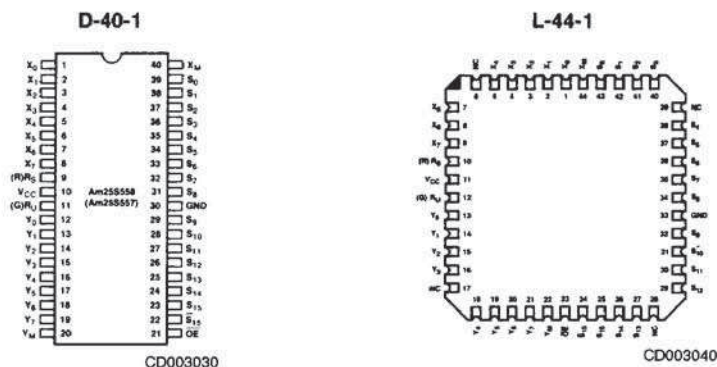

Pin assignments shown are for Am25S558. G and R shown in parentheses are pin assignments for Am25S557.

METALLIZATION AND PAD LAYOUT

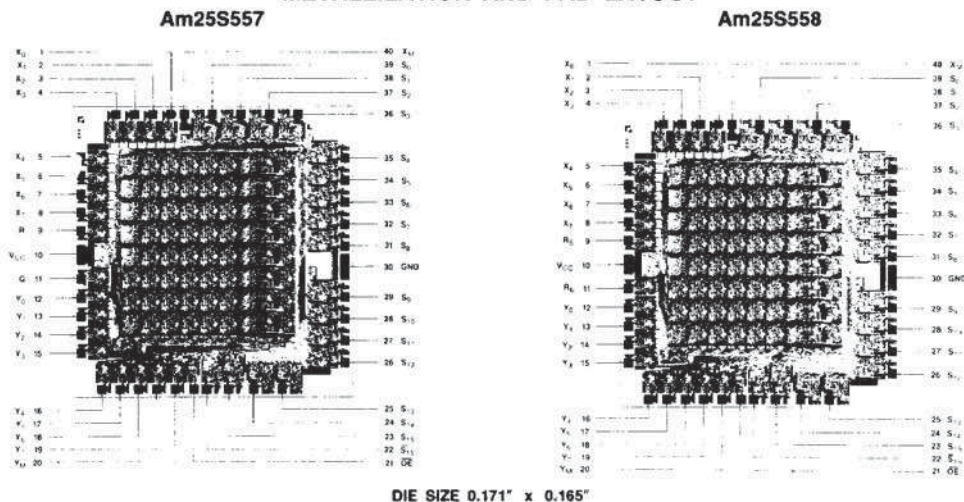

9

ORDERING INFORMATION

AMD products are available in several packages and operating ranges. The order number is formed by a combination of the following: Device number, speed option (if applicable), package type, operating range and screening option (if desired).

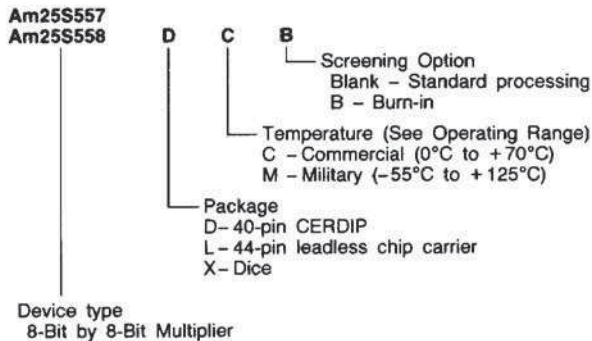

Valid Combinations	
Am25S557	DC, DM LC, LM
Am25S558	DC, DM LC, LM

Valid Combinations
Consult the AMD sales office in your area to determine if a device is currently available in the combination you wish.

PIN DESCRIPTION

Pin No.	Name	I/O	Description
	X ₀ -X ₇	I	Multiplicand 8-bit data inputs.
	Y ₀ -Y ₇	I	Multiplier 8-bit data inputs.
	X _M , Y _M	I	Mode control inputs for each data word; LOW for unsigned data and HIGH for two's complement data.
	S ₀ -S ₁₅	O	Product 16-bit output.
23	S ₁₅		Inverted MSB for expansion.
9, 11	R _S , R _U	I	Rounding inputs for signed and unsigned data, respectively (Am25S558 only).
11	G		Transparent Latch Enable (Am25S557 only).
21	OE	O	Three-state enable for S ₀ -S ₁₅ outputs.
9	R	I	Rounding input for signed or unsigned data (combined internally with X _M , Y _M in Am25S557 only).

MODE CONTROL INPUTS

Operating Mode	Input Data		Mode Control Inputs	
	X ₀ -X ₇	Y ₀ -Y ₇	X _M	Y _M
UNSIGNED	UNSIGNED	UNSIGNED	L	L
MIXED	UNSIGNED	2's COMP	L	H
	2's COMP	UNSIGNED	H	L
SIGNED	2's COMP	2's COMP	H	H

**ROUNDING INPUTS
Am25S557**

Inputs			Adds	
X _M	Y _M	R	2 ⁷	2 ⁶
L	L	H	YES	NO
L	H	H	NO	YES
H	L	H	NO	YES
H	H	H	NO	YES
X	X	L	NO	NO

Am25S558

Inputs		Adds		Normally Used With	
R _U	R _S	2 ⁷	2 ⁶	X _M	Y _M
L	L	NO	NO	X	X
L	H	NO	YES	X _M + Y _M = H	
H	L	YES	NO	L	L
H	H	YES	YES	*	*

* Most rounding applications require a HIGH level for R_U or R_S, but not both.

**I/O MAPPED INTERFACE
WITH MOS MICROPROCESSOR**

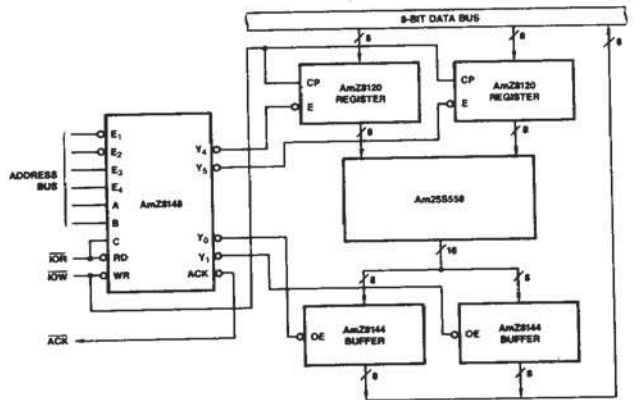

AF001270

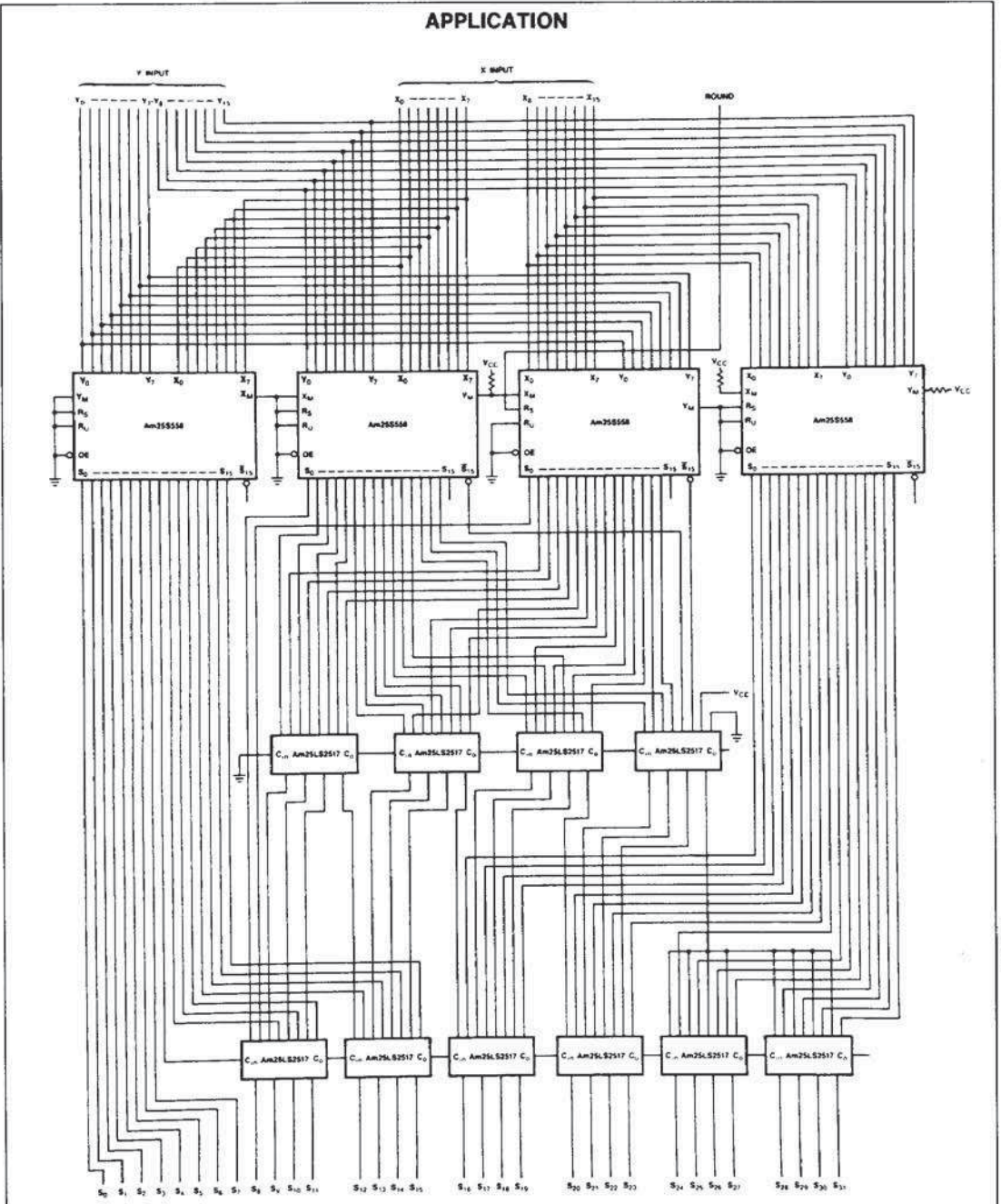

AF001310

Figure 1. High-Speed 16 x 16 2's Complement Multiplication.

ABSOLUTE MAXIMUM RATINGS

Storage Temperature	-65°C to +150°C
Ambient Temperature Under Bias	-55°C to +125°C
Supply Voltage to Ground Potential	
Continuous	-0.5V to +7.0V
DC Voltage Applied to Outputs For	
High Output State	-0.5V to +V _{CC} max
DC Input Voltage	-0.5V to +5.5V
DC Output Current, Into Outputs	30mA
DC Input Current	-30mA to +5.0mA

Stresses above those listed under ABSOLUTE MAXIMUM RATINGS may cause permanent device failure. Functionality at or above these limits is not implied. Exposure to absolute maximum ratings for extended periods may affect device reliability.

OPERATING RANGES

Commercial (C) Devices

Temperature	0°C to +70°C
Supply Voltage	+4.75V to +5.25V

Military (M) Devices

Temperature	-55°C to +125°C
Supply Voltage	+4.5V to +5.5V

Operating ranges define those limits over which the functionality of the device is guaranteed.

DC CHARACTERISTICS over operating range unless otherwise specified

Parameters	Description	Test Conditions (Note 2)		Min	Typ (Note 1)	Max	Units	
V _{OH}	Output HIGH Voltage	V _{CC} = MIN V _{IN} = V _{IH} or V _{IL}	V _{IL} = 0.8V V _{IH} = 2.0V	I _{OH} = -2.0mA	2.4	3.0	Volts	
V _{OL}	Output LOW Voltage	V _{CC} = MIN V _{IN} = V _{IH} or V _{IL}	V _{IL} = 0.8V V _{IH} = 2.0V I _{OL} = 8.0mA			0.3	0.5	Volts
V _{IH}	Input HIGH Level	Guaranteed input logical HIGH voltage for all inputs		2.0			Volts	
V _{IL}	Input LOW Level	Guaranteed input logical LOW voltage for all inputs		MIL		0.8	Volts	
				COM'L		0.8		
V _I	Input Clamp Voltage	V _{CC} = MIN, I _{IN} = -18mA				-1.5	Volts	
I _{IL}	Input LOW Current	V _{CC} = MAX, V _{IN} = 0.5V				-1.0	mA	
I _{IH}	Input HIGH Current	V _{CC} = MAX, V _{IN} = 2.4V				100	μA	
I _I	Input HIGH Current	V _{CC} = MAX, V _{IN} = 5.5V				1	mA	
I _O	Off State (High Impedance) Output Current	V _{CC} = MAX		V _O = 0.5V		-100	μA	
				V _O = 2.4V		+100		
I _{SC}	Output Short Circuit Current (Note 3)	V _{CC} = MAX.		-20		-90	mA	
I _{CC}	Power Supply Current (Note 4)	V _{CC} = MAX				280	mA	

- Notes: 1. Typical limits are at V_{CC} = 5.0V, 25°C ambient and maximum loading.
 2. For conditions shown as MIN or MAX, use the appropriate value specified under Operating Ranges for the applicable device type.
 3. Not more than one output should be shorted at a time. Duration of the short circuit test should not exceed one second.
 4. Test with pin 21 at 4.5V, all other input pins at GND, all outputs open Am25S557 conditions the same except initialize with G (pin 11) at 4.5V, then GND.

SWITCHING TEST CIRCUIT

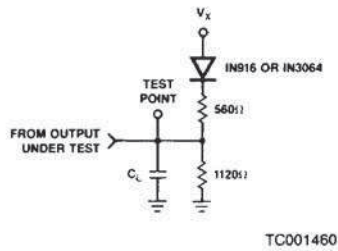

TC001460

SWITCHING TEST WAVEFORMS

Test	V _x	Output Waveform – Measurement Level
All t _{PD} S	5.0V	
t _{PHZ}	0.0V	
t _{PLZ}	5.0V	
t _{PZH}	0.0V	
t _{PZL}	5.0V	

WF002350

C_L Includes probe and jig capacitance.

SET-UP AND HOLD TIMES

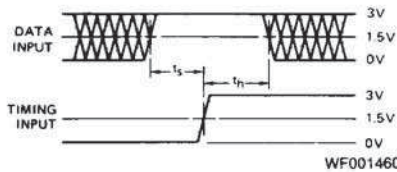

WF001460

PULSE WIDTH

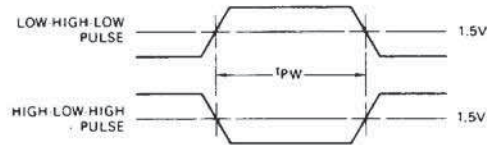

WF001270

- Notes: 1. Diagram shown for HIGH data only. Output transition may be opposite sense.
 2. Cross hatched area is don't care condition.

SWITCHING CHARACTERISTICS over operating range unless otherwise specified*

Parameters	Description	Test Conditions	COMMERCIAL			MILITARY			Units
			Am25S557			Am25S557			
			Min	Typ	Max	Min	Typ	Max	
t _{PD}	X _i , Y _i to S ₀ to S ₇	C _L = 30pF R _L = 560Ω (See test figures)		45	60		55	70	ns
t _{PD}	X _i , Y _i to S ₈ to S ₁₅ or S ₁₅			50	80		60	90	ns
t _s	X _i , Y _i to G Set-up Time		65			75			ns
t _h	X _i , Y _i to G Hold Time		-5			-5			ns
t _{PD}	G to S ₁			30	45		30	50	ns
t _{PW}	Latch Enable Pulse Width		25	15		30	15		ns
t _{PHZ}	OE to S ₀ to S ₁₅			15	30		15	40	ns
t _{PHZ}	OE to S ₁₅			25	40		25	50	ns
t _{PLZ}	OE to S ₁			15	30		15	40	ns
t _{PZH}	OE to S ₁			20	35		20	40	ns
t _{PZL}	OE to S ₁			20	35		20	40	ns

*AC performance over the operating temperature range is guaranteed by testing defined in Group A, Subgroup 9.

SWITCHING CHARACTERISTICS over operating range unless otherwise specified*

Parameters	Description	Test Conditions	COMMERCIAL			MILITARY			Units
			Am25S558			Am25S558			
			Min	Typ	Max	Min	Typ	Max	
t_{PD}	X_1, Y_1 to S_0 to S_7	$C_L = 30\text{pF}$ $R_L = 580\Omega$ (See test figures)		35	55		35	65	ns
t_{PD}	X_1, Y_1 to S_0 to S_{15} or \bar{S}_{15}			55	75		55	85	ns
t_{PHZ}	\bar{OE} to S_0 to S_{15}			15	30		15	40	ns
t_{PHZ}	\bar{OE} to \bar{S}_{15}			25	40		25	50	ns
t_{PLZ}	\bar{OE} to S_1			15	30		15	40	ns
t_{PZH}	\bar{OE} to S_1			20	35		20	40	ns
t_{PZL}	\bar{OE} to S_1			20	35		20	40	ns

*AC performance over the operating temperature range is guaranteed by testing defined in Group A, Subgroup 9.

Am25S557/Am25S558 INPUT/OUTPUT CURRENT INTERFACE CONDITIONS

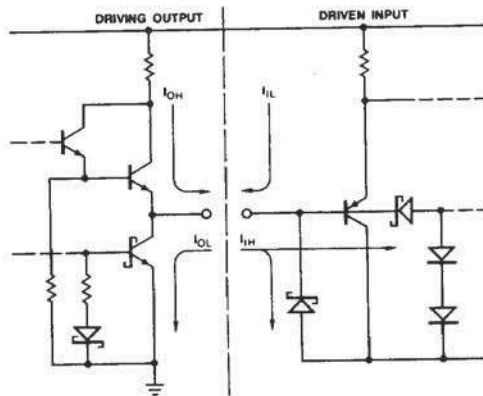

IC000380

RELATED PRODUCTS

Part No.	Description
Am29516/7	16 by 16-Bit Multiplier
Am25S05	4 by 2-Bit Multiplier
Am25LS14A	8-Bit Serial/Parallel Multiplier