

AM26LS32B

Quad Differential Line Receiver

The AM26LS32B is a quad line receiver designed to meet the requirements of RS-422 and RS-423, CCITT V.10 and V.11, and Federal Standards 1020 and 1030 for balanced and unbalanced digital data transmission. The AM26LS32B features an input sensitivity of 200 mV over the common mode input voltage range of -7 V to +12 V.

The AM26LS32B is the first device in the AM26LS32 configuration to guarantee minimum hysteresis and propagation delay skew while maintaining better propagation delay guarantees than the AM26LS32. This allows a more critical analysis of performance in high noise environments and better performance in terms of signal quality, resulting in better system performance.

Rochester Electronics Manufactured Components

Rochester branded components are manufactured using either die/wafers purchased from the original suppliers or Rochester wafers recreated from the original IP. All recreations are done with the approval of the OCM.

Parts are tested using original factory test programs or Rochester developed test solutions to guarantee product meets or exceeds the OCM data sheet.

Quality Overview

- ISO-9001
- AS9120 certification
- Qualified Manufacturers List (QML) MIL-PRF-38535
 - Class Q Military
 - Class V Space Level
- Qualified Suppliers List of Distributors (QSLD)
 - Rochester is a critical supplier to DLA and meets all industry and DLA standards.

Rochester Electronics, LLC is committed to supplying products that satisfy customer expectations for quality and are equal to those originally supplied by industry manufacturers.

The original manufacturer's datasheet accompanying this document reflects the performance and specifications of the Rochester manufactured version of this device. Rochester Electronics guarantees the performance of its semiconductor products to the original OEM specifications. 'Typical' values are for reference purposes only. Certain minimum or maximum ratings may be based on product characterization, design, simulation, or sample testing.



Am26LS32B

Quad Differential Line Receiver

DISTINCTIVE CHARACTERISTICS

- ± 120 mV sensitivity over V_{IN} range of 0 V to 5 V
- ± 200 mV sensitivity over V_{CM} range
- -7 V to +12 V input voltage range – differential or common mode
- Guaranteed input voltage hysteresis limits
 - 65 mV minimum
 - 240 mV maximum
- 3 V maximum open circuit input voltage
- Three-state outputs disabled during power-up and power-down
- Maximum guarantees for t_{PD} skew
- All AC and DC parameters guaranteed over COM'L and MIL operating temperature ranges
- Single +5 V supply
- Advanced low-power Schottky processing

GENERAL DESCRIPTION

The Am26LS32B is a quad line receiver designed to meet the requirements of RS-422 and RS-423, CCITT V.10 and V.11, and Federal Standards 1020 and 1030 for balanced and unbalanced digital data transmission.

The Am26LS32B features an input sensitivity of 200 mV over the common mode input voltage range of -7 V to +12 V.

The Am26LS32B is the first device in the Am26LS32 configuration to guarantee minimum hysteresis and propagation delay skew while maintaining better propagation delay guarantees than the Am26LS32. This al-

lows a more critical analysis of performance in high noise environments and better performance in terms of signal quality, resulting in better system performance.

The Am26LS32B provides an enable and disable function common to all four receivers. It features three-state outputs with 24 mA sink capability and incorporates a fail safe input-output relationship which keeps the outputs high when the inputs are open.

The Am26LS32B is constructed using Advanced Low-Power Schottky processing.

BLOCK DIAGRAM

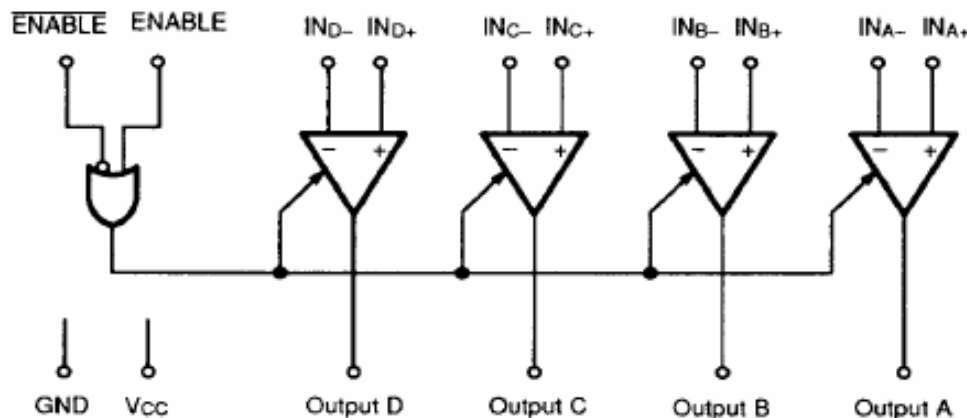

01024-001B

RELATED AMD PRODUCTS

Part No.	Description
26LS29	Quad Three-State Single Ended RS-423 Line Driver
26LS30	Dual Differential RS-422 Party Line/Quad Single Ended RS-423 Line Driver
26LS33	Quad Differential Line Receiver

CONNECTION DIAGRAMS

Top View

DIP

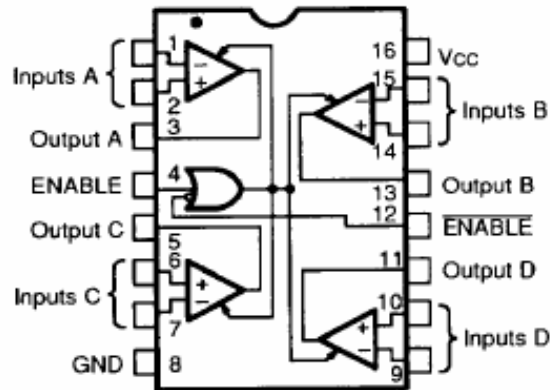

01024-002A

LCC

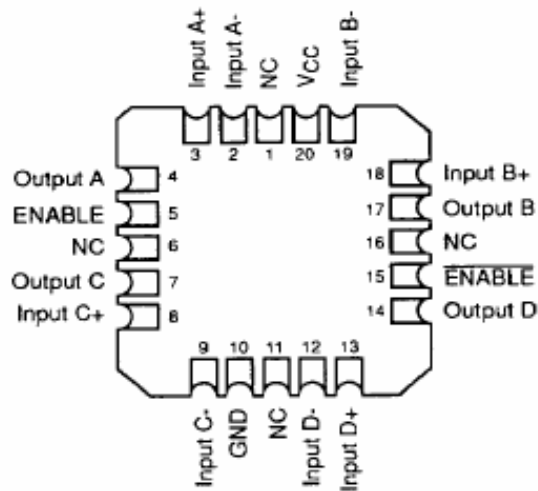

01024-003A

Note:

Pin 1 is marked for orientation.

ABSOLUTE MAXIMUM RATINGS

Supply Voltage	7.0 V
Common Mode Range	± 25 V
Differential Input Voltage	± 25 V
Enable Voltage	7.0 V
Output Sink Current	50 mA
Storage Temperature Range	-65 to +165°C

Stresses above those listed under Absolute Maximum Ratings may cause permanent device failure. Functionality at or above these limits is not implied. Exposure to absolute maximum ratings for extended periods may affect device reliability.

OPERATING RANGES

Commercial (C) Devices	
Temperature	0 to +70°C
Supply Voltage	+4.5 V to +5.5 V
Military (M) Devices	
Temperature	-55 to +125°C
Supply Voltage	+4.5 V to +5.5 V

Operating ranges define those limits between which the functionality of the device is guaranteed.

DC CHARACTERISTICS over operating ranges unless otherwise specified

Parameter Symbol	Parameter Description	Test Conditions	Min.	Typ. (Note 1)	Max.	Unit
V _{TH}	Differential Input Voltage (Note 5)	V _{OUT} = V _{OL} or V _{OH} , 0 ≤ V _{CM} ≤ +5 V	-100	±60	100	mV
		-7 V ≤ V _{CM} ≤ +12 V	-200		200	
V _{HYST}	Input Hysteresis	V _{CC} = 5.0 V	65		240	mV
V _{IOC}	Open Circuit Input Voltage		1.5		3.0	V
R _{IN}	Input Resistance (Note 4)	-15 V ≤ V _{CM} ≤ +15 V (One input AC ground)	6.0	9.8		kΩ
I _{IN}	Input Current (Under Test)	V _{IN} = +15 V, Other Input -15 V ≤ V _{IN} ≤ +15 V			2.3	mA
I _{IN}	Input Current (Under Test)	V _{IN} = -15 V, Other Input -15 V ≤ V _{IN} ≤ +15 V			-2.8	mA
V _{OH}	Output HIGH Voltage	V _{CC} = Min., ΔV _{IN} = +1.0 V, I _{OH} = -12 mA	2.0			V
		V _{ENABLE} = 0.8 V, I _{OH} = -1 mA	2.4			
V _{OL}	Output LOW Voltage	V _{CC} = Min., ΔV _{IN} = -1.0 V, I _{OL} = 16 mA			0.4	V
		V _{ENABLE} = 0.8 V, I _{OL} = 24 mA			0.5	
V _{IL}	Enable LOW Voltage	(Note 2)			0.8	V
V _{IH}	Enable HIGH Voltage	(Note 2)	2.0			V
V _{IC}	Enable Clamp Voltage	V _{CC} = Min., I _{IN} = -18 mA			-1.5	V
I _O	Off-State (High Impedance) Output Current	V _{CC} = Max., V _O = 2.4 V			50	μA
		V _O = 0.4 V			-50	
I _{IL}	Enable LOW Current	V _{IN} = 0.4 V, V _{CC} = Max.		-0.2	-0.36	mA
I _{IH}	Enable HIGH Current	V _{IN} = 2.7 V, V _{CC} = Max.			20	μA
I _I	Enable Input High Current	V _{IN} = 5.5 V, V _{CC} = Max.			100	μA
I _{SC}	Output Short Circuit Current	V _O = 0 V, V _{CC} = Max., ΔV _{IN} = +1.0 V (Note 3)	-30	-65	-120	mA
I _{CC}	Power Supply Current	V _{CC} = Max., All V _{IN} = GND, Outputs Disabled		52	70	mA

Notes:

- All typical values are V_{CC} = 5.0 V, T_A = 25°C.
- Input thresholds are tested during DC tests and may be done in combination with testing of other DC parameters.
- Not more than one output should be shorted at a time. Duration of short circuit test should not exceed one second.
- R_{IN} is not directly tested but is correlated. (See Attachment I)
- Input voltage is not tested directly due to tester accuracy limitations but is tester correlated. (See Attachment II)

SWITCHING CHARACTERISTICS ($T_A = +25^\circ\text{C}$, $V_{CC} = 5.0\text{ V}$)





Parameter Symbol	Parameter Description	Test Conditions	Min.	Typ.	Max.	Unit
t_{PLH}	Propagation Delay, Input to Output	$C_L = 50\text{ pF}$ See test circuit		16	21	ns
t_{PHL}				17	21	ns
t_{SKEW}	Propagation Delay Skew, $t_{PLH} - t_{PHL}$			1.5	3.0	ns
t_{ZL}	Output Enable Time, ENABLE to Output			16	22	ns
t_{ZH}				10	16	ns
t_{LZ}	Output Disable Time, ENABLE to Output		$C_L = 5\text{ pF}$ See test circuit		11	18
t_{HZ}				13	18	ns

SWITCHING CHARACTERISTICS over operating ranges unless otherwise specified

Parameter Symbol	Parameter Description	Test Conditions	Commercial		Military		Unit
			Min.	Max.	Min.	Max.	
t_{PLH}	Propagation Delay, Input to Output	$C_L = 50\text{ pF}$ See test circuit		26		26	ns
t_{PHL}				26		26	ns
t_{SKEW}	Propagation Delay Skew, $t_{PLH} - t_{PHL}$			4.0		4.0	ns
t_{ZL}	Output Enable Time, ENABLE to Output			33		33	ns
t_{ZH}				22		22	ns
t_{LZ}	Output Disable Time, ENABLE to Output		$C_L = 5\text{ pF}$ See test circuit		27		27
t_{HZ}				27		27	ns

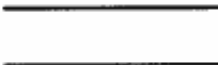
Parameter Symbol	Parameter Description	Test Conditions	Min.	Typ.	Max.	Unit
Tristate Delays for $\overline{\text{ENABLE}}$ ($T_A = +25^\circ\text{C}$)						
t_{PZH}	Propagation Delay From $\overline{\text{ENABLE}}$ to Output	$C_L = 50\text{ pF}$, $R_{L1} = 1\text{ k}\Omega$, $R_{L2} = 280\ \Omega$			26	ns
t_{PZL}	Propagation Delay From $\overline{\text{ENABLE}}$ to Output	$C_L = 50\text{ pF}$, $R_{L1} = 1\text{ k}\Omega$, $R_{L2} = 280\ \Omega$			33	ns
t_{PHZ}	Propagation Delay From $\overline{\text{ENABLE}}$ to Output	$C_L = 5\text{ pF}$, $R_{L1} = 1\text{ k}\Omega$, $R_{L2} = 280\ \Omega$			20	ns
t_{PLZ}	Propagation Delay From $\overline{\text{ENABLE}}$ to Output	$C_L = 5\text{ pF}$, $R_{L1} = 1\text{ k}\Omega$, $R_{L2} = 280\ \Omega$			20	ns
Tristate Delays for $\overline{\text{ENABLE}}$ (-55°C to $+125^\circ\text{C}$)						
t_{PZH}	Propagation Delay From $\overline{\text{ENABLE}}$ to Output	$C_L = 50\text{ pF}$, $R_{L1} = 1\text{ k}\Omega$, $R_{L2} = 280\ \Omega$			39	ns
t_{PZL}	Propagation Delay From $\overline{\text{ENABLE}}$ to Output	$C_L = 50\text{ pF}$, $R_{L1} = 1\text{ k}\Omega$, $R_{L2} = 280\ \Omega$			49	ns
t_{PHZ}	Propagation Delay From $\overline{\text{ENABLE}}$ to Output	$C_L = 5\text{ pF}$, $R_{L1} = 1\text{ k}\Omega$, $R_{L2} = 280\ \Omega$			30	ns
t_{PLZ}	Propagation Delay From $\overline{\text{ENABLE}}$ to Output	$C_L = 5\text{ pF}$, $R_{L1} = 1\text{ k}\Omega$, $R_{L2} = 280\ \Omega$			30	ns

KEY TO SWITCHING WAVEFORMS

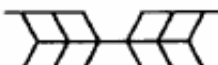
WAVEFORM	INPUTS	OUTPUTS
	Must Be Steady	Will Be Steady
	May Change from H to L	Will Be Changing from H to L
	May Change from L to H	Will Be Changing from L to H
	Don't Care, Any Change Permitted	Changing, State Unknown
	Does Not Apply	Center Line is High Impedance "Off" State

KS000010

SWITCHING WAVEFORMS

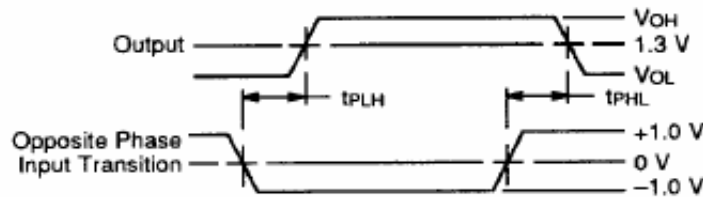

Propagation Delay (Notes 1 and 3)

01024-005A

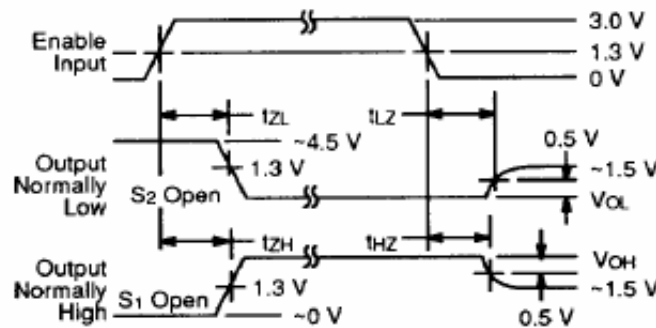

Enable and Disable Times (Notes 2 and 3)

Notes:

1. Diagram shown for ENABLE LOW.
2. S₁ and S₂ of Load Circuit are closed except where shown.
3. Pulse Generator for All Pulses: Rate ≤ 1.0 MHz; Z₀ = 50 Ω; t_r ≤ 2.5 ns; t_f ≤ 2.5 ns.

01024-006A

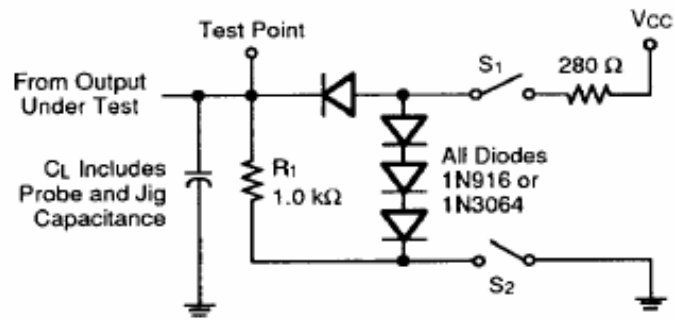
SWITCHING TEST CIRCUIT FOR THREE-STATE OUTPUTS

01024-007A