

AM26S12, AM26S12A

Quad Bus Transceivers

The AM26S12/AM26S12A are high-speed quad Bus Transceivers consisting of four high-speed bus drivers with open-collector outputs capable of sinking 100mA at 0.7 volts and four high-speed bus receivers. Each driver output is brought out and also connected internally to the high-speed bus receiver. The receiver has an input hysteresis characteristics and a TTL output capable of driving ten TTL loads.

An active LOW, two-input AND gate controls the four drivers so that outputs of different device drivers can be connected together for party-line operation. The enable inputs can be conveniently driven by active LOW decoders such as the AM54S/74S139.

Rochester Electronics Manufactured Components

Rochester branded components are manufactured using either die/wafers purchased from the original suppliers or Rochester wafers recreated from the original IP. All recreations are done with the approval of the OCM.

Parts are tested using original factory test programs or Rochester developed test solutions to guarantee product meets or exceeds the OCM data sheet.

Quality Overview

- ISO-9001
- AS9120 certification
- Qualified Manufacturers List (QML) MIL-PRF-38535
 - Class Q Military
 - Class V Space Level
- Qualified Suppliers List of Distributors (QSLD)
 - Rochester is a critical supplier to DLA and meets all industry and DLA standards.

Rochester Electronics, LLC is committed to supplying products that satisfy customer expectations for quality and are equal to those originally supplied by industry manufacturers.

The original manufacturer's datasheet accompanying this document reflects the performance and specifications of the Rochester manufactured version of this device. Rochester Electronics guarantees the performance of its semiconductor products to the original OEM specifications. 'Typical' values are for reference purposes only. Certain minimum or maximum ratings may be based on product characterization, design, simulation, or sample testing.

Am26S12/Am26S12A

Quad Bus Transceivers

Am26S12/Am26S12A

DISTINCTIVE CHARACTERISTICS

- Quad high-speed bus transceivers
- Driver outputs can sink 100mA at 0.7V typically
- Choice of receiver hysteresis characteristics

GENERAL DESCRIPTION

The Am26S12/Am26S12A are high-speed quad Bus Transceivers consisting of four high-speed bus drivers with open-collector outputs capable of sinking 100mA at 0.7 volts and four high-speed bus receivers. Each driver output is brought out and also connected internally to the high-speed bus receiver. The receiver has an input hysteresis characteristic and a TTL output capable of driving ten TTL loads.

An active LOW, two-input AND gate controls the four drivers so that outputs of different device drivers can be connected together for party-line operation. The enable inputs can be conveniently driven by active LOW decoders such as the Am54S/74S139.

The high-drive capability in the LOW state allows party-line operation with a line impedance as low as 100Ω. The line

can be terminated at both ends, and still give considerable noise margin at the receiver. The hysteresis characteristic of the Am26S12 receiver is chosen so that the receiver output switches to a HIGH logic level when the receiver input is at a HIGH logic level and moves to 1.4 volts typically, and switches to a LOW logic level when the receiver input is at a LOW logic level and moves to 2.0 volts typically. This hysteresis characteristic makes the receiver very insensitive to noise on the bus.

The Am26S12A is functionally identical to the Am26S12 but has a different hysteresis characteristic so that the output switches with the input being typically at 1.2 volts or 2.25 volts. In both devices the threshold margin, the difference between the switching points, is greater than 0.4 volts.

BLOCK DIAGRAM

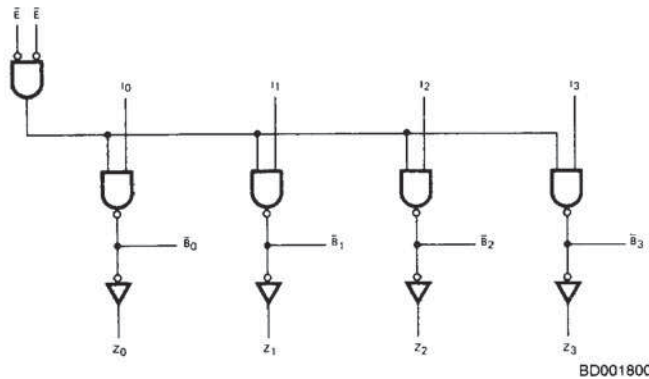

RELATED PRODUCTS

Part No.	Description
26S10	Quad Bus Transceiver
26S11	Quad Bus Transceiver
2915A	Quad Three-State Bus Transceiver with Interface Logic
2916A	Quad Three-State Bus Transceiver with Interface Logic
2917A	Quad Three-State Bus Transceiver with Interface Logic

10

05395A/05396A

**CONNECTION DIAGRAM
Top View**

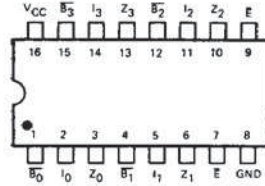

CD004070

Note: Pin 1 is marked for orientation

LOGIC SYMBOL

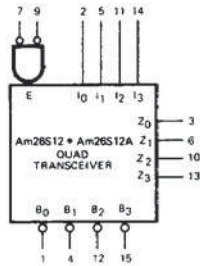

LS000860

V_{CC} = Pin 16
GND = Pin 8

METALLIZATION AND PAD LAYOUT

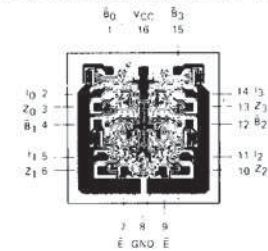

DIE SIZE: 0.071" x 0.072"

ORDERING INFORMATION

AMD products are available in several packages and operating ranges. The order number is formed by a combination of the following: Device number, speed option (if applicable), package type, operating range and screening option (if desired).

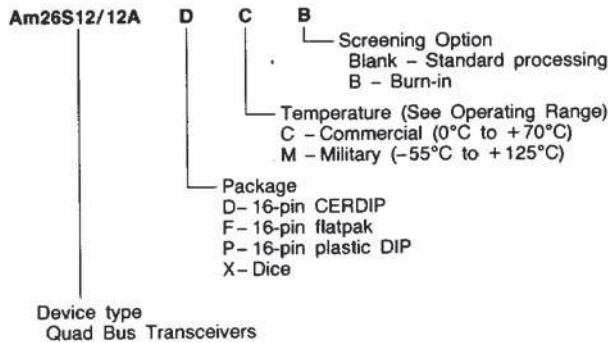

Valid Combinations	
Am26S12	PC DC, DM
Am26S12A	FM XC, XM

Valid Combinations
Consult the AMD sales office in your area to determine if a device is currently available in the combination you wish.

Am26S12/26S12A APPLICATION

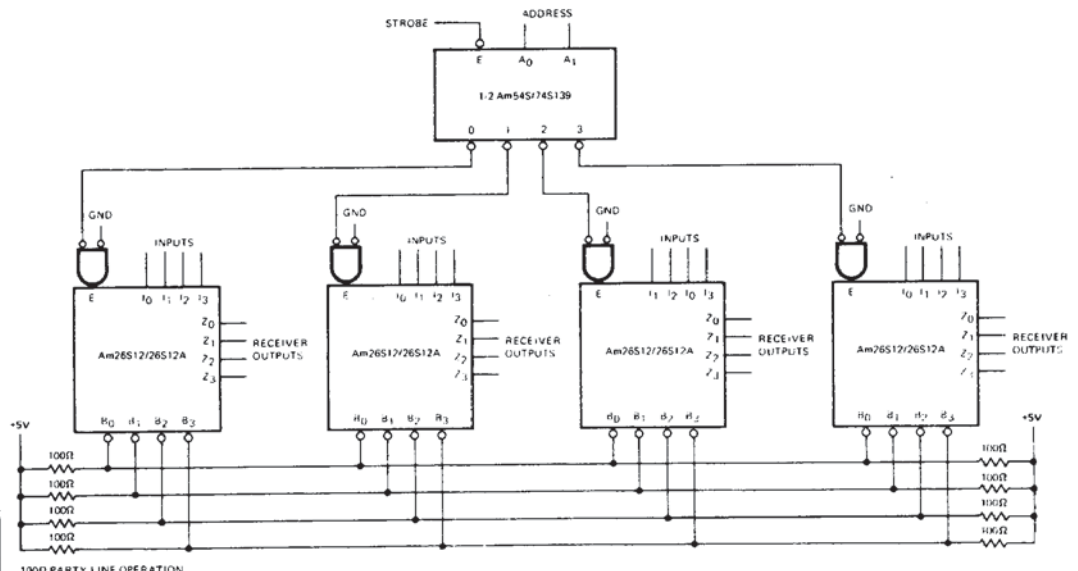

AF001030

ABSOLUTE MAXIMUM RATINGS

Storage Temperature	-65°C to +150°C
Temperature (Ambient) Under Bias	-55°C to +125°C
Supply Voltage to Ground Potential (Pin 16 to Pin 8) Continuous	-0.5V to +7.0V
DC Voltage Applied to Outputs For High Output State	-0.5V to +V _{CC} max
DC Input Voltage	-0.5V to +5.5V
DC Output Current, Into (Bus)	200mA
DC Output Current, Into Outputs (Receiver)	30mA
DC Input Current	-30mA to +5.0mA

Stresses above those listed under ABSOLUTE MAXIMUM RATINGS may cause permanent device failure. Functionality at or above these limits is not implied. Exposure to absolute maximum ratings for extended periods may affect device reliability.

OPERATING RANGES

Commercial (C) Devices	
Temperature	0°C to +70°C
Supply Voltage	+4.75V to +5.25V

Military (M) Devices	
Temperature	-55°C to +125°C
Supply Voltage	+4.5V to +5.5V

Operating ranges define those limits over which the functionality of the device is guaranteed.

DC CHARACTERISTICS over operating range unless otherwise specified

Parameters	Description	Test Conditions	Min	Typ (Note 1)	Max	Units		
I _{CC}	Power Supply Current	V _{CC} = MAX		46	70	mA		
I _{BUS}	Bus Leakage Current	V _{CC} = MAX or 0V; V _{BUS} = 4.0V; Driver in OFF State			100	μA		
Driver Characteristics								
V _{OL} (Note 1)	Output LOW Voltage	V _{CC} = MIN V _{IN} = V _{IH} or V _{IL}	COM'L	I _{OL} = 100mA		0.7	0.8	Volts
			MIL	I _{OL} = 60mA		0.55	0.7	Volts
				I _{OL} = 100mA		0.7	0.85	Volts
V _{IH}	Input HIGH Voltage		2.0			Volts		
V _{IL}	Input LOW Voltage				0.8	Volts		
V _I	Input Clamp Voltage	V _{CC} = MIN, I _{IN} = -18mA			-1.2	Volts		
I _I	Input Current at Maximum Input Voltage	V _{CC} = MAX, V _I = 5.5V			1.0	mA		
I _{IH}	Unit Load Input HIGH Current	V _{CC} = MAX, V _I = 2.4V		1.0	40	μA		
I _{IL}	Unit Load Input LOW Current	V _{CC} = MAX, V _I = 0.4V		-0.4	-1.6	mA		
Receiver Characteristics								
V _{OH}	Output HIGH Voltage	V _{CC} = MIN, I _{OH} = -800μA V _{IN} = V _{IL} (Receiver)	2.4			Volts		
V _{OL}	Output LOW Voltage	V _{CC} = MIN, I _{OL} = 20mA V _{IN} = V _{IL} (Receiver)		0.4	0.5	Volts		
V _{IH}	Input HIGH Level Threshold	E = H	Am26S12	1.8	2.0	2.2	Volts	
			Am26S12A	2.05	2.25	2.45		
V _{IL}	Input LOW Level Threshold	E = H	Am26S12	1.2	1.4	1.6	Volts	
			Am26S12A	1.0	1.2	1.4		
V _{TM}	Input Threshold Margin	E = H	0.4			Volts		
I _{OS}	Output Short Circuit Current	V _{CC} = MAX, V _{OUT} = 0.0V	-20		-55	mA		

- Notes: 1. Typical limits are at V_{CC} = 5.0V, 25°C ambient and maximum loading.
2. For the Am26S12FM, Am26S12AFM the output current must be limited at 60mA or the maximum case temperature limited to 125°C for correct operation.
3. Hysteresis characteristics data tested at 25°C only.

SWITCHING CHARACTERISTICS (T_A = +25°C, V_{CC} = 5.0V)

Parameters	Description	Conditions	Min	Typ	Max	Units
t _{PLH}	Turn Off Delay Input to Bus	C _{LB} = 15 pF, R _{LB} = 100 Ω		7	11	ns
t _{PHL}	Turn On Delay Input to Bus	C _{LB} = 300 pF, R _{LB} = 50 Ω		14	21	ns
t _{PLH}	Turn Off Delay Enable to Bus	C _{LB} = 15 pF, R _{LB} = 50 Ω		10	15	ns
t _{PHL}	Turn On Delay Enable to Bus	C _{LB} = 15 pF, R _{LB} = 50 Ω		10	15	ns
t _{PLH}	Turn Off Delay Bus to Output	C _L = 15 pF		18	26	ns
t _{PHL}	Turn On Delay Bus to Output	C _L = 15 pF		18	26	ns