

AM2907, AM2908

Quad Bus Transceivers with Interface Logic

The AM2907 and AM2908 are high-performance bus transceivers intended for bipolar or MOS microprocessor system applications. These devices consist of four D-type edge-triggered flip-flops. The flip-flop outputs are connected to four open-collector bus drivers. Each bus driver is internally connected to one input of a differential amplifier in the receiver. The four receiver differential amplifier outputs drive four D-type latches, that feature three-state outputs. The devices also contain a four-bit odd parity checker/generator.

Rochester Electronics Manufactured Components

Rochester branded components are manufactured using either die/wafers purchased from the original suppliers or Rochester wafers recreated from the original IP. All recreations are done with the approval of the OCM.

Parts are tested using original factory test programs or Rochester developed test solutions to guarantee product meets or exceeds the OCM data sheet.

Quality Overview

- ISO-9001
- AS9120 certification
- Qualified Manufacturers List (QML) MIL-PRF-38535
 - Class Q Military
 - Class V Space Level
- Qualified Suppliers List of Distributors (QSLD)
 - Rochester is a critical supplier to DLA and meets all industry and DLA standards.

Rochester Electronics, LLC is committed to supplying products that satisfy customer expectations for quality and are equal to those originally supplied by industry manufacturers.

The original manufacturer's datasheet accompanying this document reflects the performance and specifications of the Rochester manufactured version of this device. Rochester Electronics guarantees the performance of its semiconductor products to the original OEM specifications. 'Typical' values are for reference purposes only. Certain minimum or maximum ratings may be based on product characterization, design, simulation, or sample testing.

Am2907/Am2908

Quad Bus Transceivers with Interface Logic

Am2907/Am2908

DISTINCTIVE CHARACTERISTICS

- Quad high-speed LSI bus-transceiver
- D-type driver register with open-collector bus driver output can sink 100mA at 0.8V max.
- Internal 4-bit odd parity checker/generator
- Receiver has output latch for pipeline operation
- Three-state receiver outputs sink 12mA
- Am2907 has 2.0V input receiver threshold; Am2908 is "DECQ or LSI-II bus compatible" with 1.5V receiver threshold

GENERAL DESCRIPTION

The Am2907 and Am2908 are high-performance bus transceivers intended for bipolar or MOS microprocessor system applications. The Am2908 is Digital Equipment Corporation "Q or LSI-II bus compatible" while the Am2907 features a 2.0V receiver threshold. These devices consist of four D-type edge-triggered flip-flops. The flip-flop outputs are connected to four open-collector bus drivers. Each bus driver is internally connected to one input of a differential amplifier in the receiver. The four receiver differential amplifier outputs drive four D-type latches, that feature three-state outputs. The devices also contain a four-bit odd parity checker/generator.

These LSI bus transceivers are fabricated using advanced low-power Schottky processing. All inputs (except the BUS inputs) are one LS unit load. The open-collector bus output can sink up to 100mA at 0.8V maximum. The BUS input differential amplifier contains disconnect protection diodes such that the bus is fail-safe when power is not applied. The bus enable input (\overline{BE}) is used to force the driver outputs to the high-impedance state. When \overline{BE} is HIGH, the driver is disabled. The open-collector structure of the driver allows wired-OR operations to be performed on the bus.

The input register consists of four D-type flip-flops with a buffered common clock. The buffered common clock (DRCP) enters the A_i data into this driver register on the LOW-to-HIGH transition.

Data from the A input is inverted at the BUS output. Likewise, data at the BUS input is inverted at the receiver output. Thus, data is non-inverted from driver input to receiver output. The four receivers each feature a built-in D-type latch that is controlled from the buffered receiver latch enable (\overline{RLE}) input. When the \overline{RLE} input is LOW, the latch is open and the receiver outputs will follow the bus inputs (BUS data inverted and \overline{OE} LOW). When the \overline{RLE} input is HIGH, the latch will close and retain the present data regardless of the bus input. The four latches have three-state outputs and are controlled by a buffered common three-state control (\overline{OE}) input. When \overline{OE} is HIGH, the receiver outputs are in the high-impedance state.

The Am2907 and Am2908 feature a built-in four-bit odd parity checker/generator. The bus enable input (\overline{BE}) controls whether the parity output is in the generate or check mode. When the bus enable is LOW (driver enabled), odd parity is generated based on the A field data input to the driver register. When \overline{BE} is HIGH, the parity output is determined by the four latch outputs of the receiver. Thus, if the driver is enabled, parity is generated and if the driver is in the high-impedance state, the BUS parity is checked.

The Am2907 has receiver threshold typically of 2.0V while the Am2908 threshold is typically 1.5V.

5

05399A

BLOCK DIAGRAM

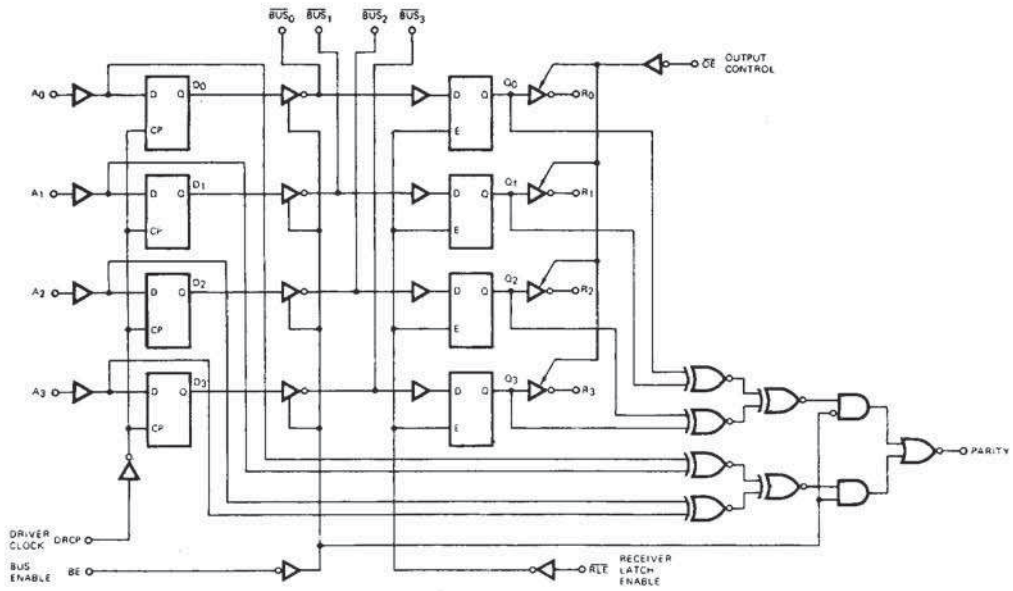

BD001890

**CONNECTION DIAGRAM
Top View**

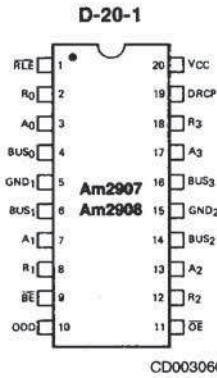

Note: Pin 1 is marked for orientation

LOGIC SYMBOL

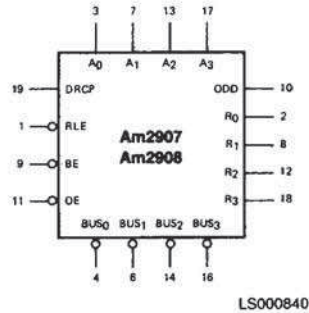

METALLIZATION AND PAD LAYOUT

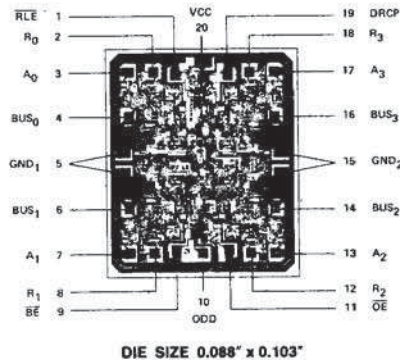

5

ORDERING INFORMATION

AMD products are available in several packages and operating ranges. The order number is formed by a combination of the following: Device number, speed option (if applicable), package type, operating range and screening option (if desired).

Am2907/
Am2908

- D** — Package
D - 20-pin CERDIP
F - 20-pin flatpak
P - 20-pin plastic DIP
X - Dice
- C** — Temperature (See Operating Range)
C - Commercial (0°C to +70°C)
M - Military (-55°C to +125°C)
- B** — Screening Option
Blank - Standard processing
B - Burn-in

Device type
Quad Bus Transceivers

Valid Combinations	
Am2907 Am2908	PC DC, DCB, DM, DMB FM, FMB XC, XM

Valid Combinations

Consult the AMD sales office in your area to determine if a device is currently available in the combination you wish.

PIN DESCRIPTION

Pin No.	Name	I/O	Description
3, 7 13, 17	A ₀ , A ₁ A ₂ , A ₃	I	The four driver register inputs.
19	DRCP	I	Driver Clock Pulse: Clock pulse for the driver register.
9	\overline{BE}	I	Bus Enable. When the Bus Enable is HIGH. The four drivers are in the high impedance state.
4 6 14 16	BUS ₀ , BUS ₁ , BUS ₂ , BUS ₃	I/O	The four driver outputs and receiver inputs (data is inverted).
2, 8, 12, 18	R ₀ , R ₁ , R ₂ , R ₃	O	The four receiver outputs. Data from the bus is inverted while data from the A inputs is non-inverted.
1	\overline{RLE}	O	Receiver Latch Enable. When \overline{RLE} is LOW, data on the BUS inputs is passed through the receiver latches. When \overline{RLE} is HIGH, the receiver latches are closed and will retain the data independent of all other inputs.
10	ODD	O	Odd parity output. Generates parity with the driver enabled, checks parity with the driver in the high-impedance state.
11	\overline{OE}	I	Output Enable. When the \overline{OE} input is HIGH, the four three-state receiver outputs are in the high-impedance state.

TRUTH TABLE

INPUTS					INTERNAL TO DEVICE		BUS	OUTPUT	FUNCTION
A _i	DRCP	\overline{BE}	\overline{RLE}	\overline{OE}	D _i	Q _i	B _i	R _i	
X	X	H	X	X	X	X	H	X	Driver output disable
X	X	X	X	H	X	X	X	Z	Receiver output disable
X	X	H	L	L	X	L	L	H	Driver output disable and receive data via Bus input
X	X	H	L	L	X	H	H	L	Driver output disable and receive data via Bus input
X	X	X	H	X	X	NC	X	X	Latch received data
L	↑	X	X	X	L	X	X	X	Load driver register
H	↑	X	X	X	H	X	X	X	Load driver register
X	L	X	X	X	NC	X	X	X	No driver clock restrictions
X	H	X	X	X	NC	X	X	X	No driver clock restrictions
X	X	L	X	X	H	X	L	X	Drive Bus

H = HIGH Z = HIGH Impedance X = Don't care i = 0, 1, 2, 3
L = LOW NC = No change ↑ = LOW to HIGH transition

PARITY OUTPUT FUNCTION TABLE

\overline{BE}	ODD PARITY OUTPUT
L	ODD = A ₀ ⊕ A ₁ ⊕ A ₂ ⊕ A ₃
H	ODD = Q ₀ ⊕ Q ₁ ⊕ Q ₂ ⊕ Q ₃

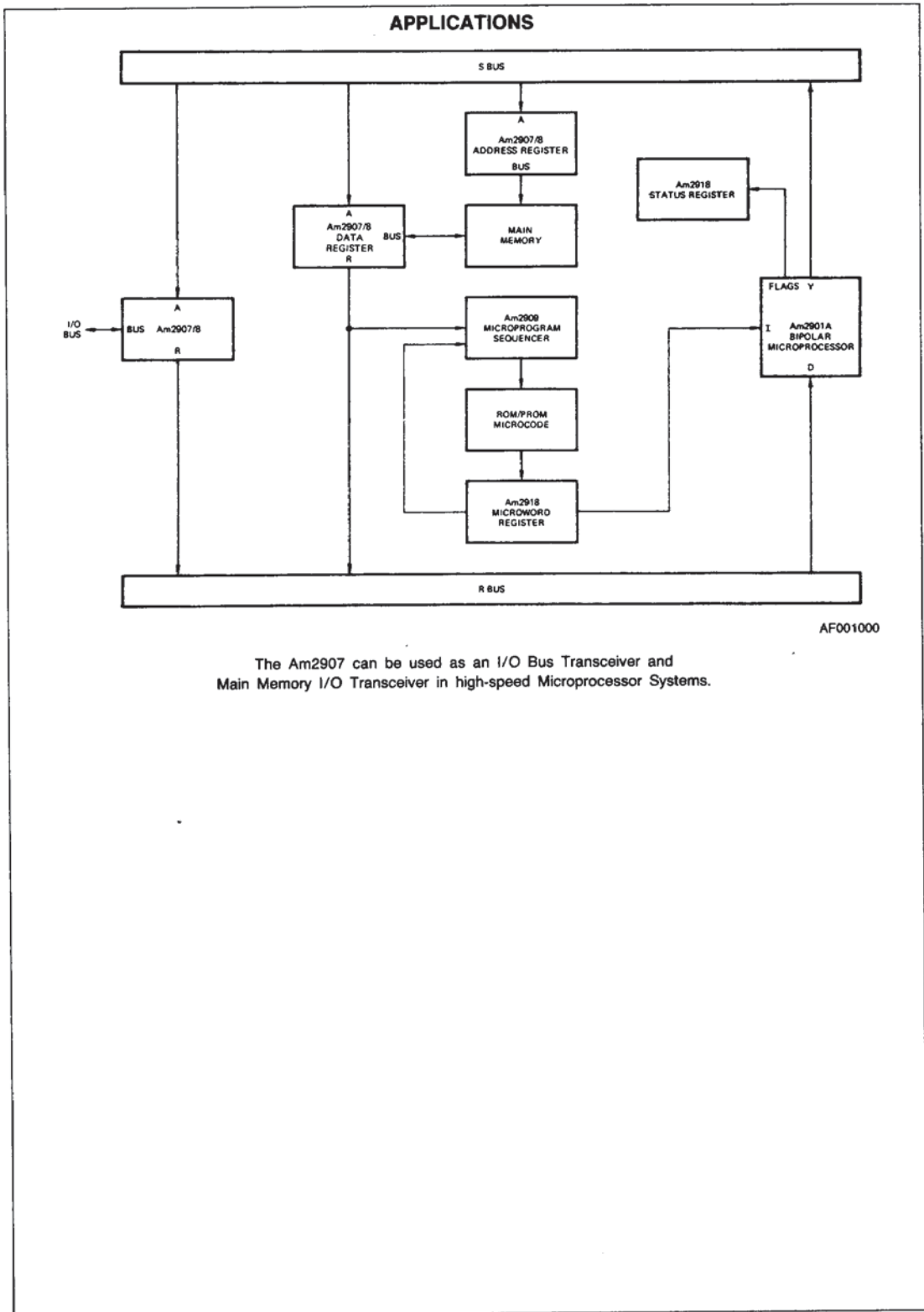

AF001000

The Am2907 can be used as an I/O Bus Transceiver and Main Memory I/O Transceiver in high-speed Microprocessor Systems.

ABSOLUTE MAXIMUM RATINGS

Storage Temperature	-65°C to +150°C
(Ambient) Temperature Under Bias	-55°C to +125°C
Supply Voltage to Ground Potential	
Continuous	-0.5V to +7.0V
DC Voltage Applied to Outputs for	
High Output State	-0.5V to +V _{CC} max
DC Input Voltage	-0.5V to +5.5V
DC Output Current, Into Bus	200mA
DC Output Current, Into Outputs	
(Except Bus)	30mA
DC Input Current	-30mA to +5.0mA

Stresses above those listed under ABSOLUTE MAXIMUM RATINGS may cause permanent device failure. Functionality at or above these limits is not implied. Exposure to absolute maximum ratings for extended periods may affect device reliability.

OPERATING RANGES

Commercial (C) Devices

Temperature	0°C to +70°C
Supply Voltage	+4.75V to +5.25V

Military (M) Devices

Temperature	-55°C to +125°C
Supply Voltage	+4.5V to +5.5V

Operating ranges define those limits over which the functionality of the device is guaranteed.

DC CHARACTERISTICS over operating range unless otherwise specified

Parameters	Description	Test Conditions (Note 2)	Min	Typ (Note 1)	Max	Units	
V _{OH}	Receiver Output HIGH Voltage	V _{CC} = MIN V _{IN} = V _{IL} or V _{IH}	MIL: I _{OH} = -1.0mA	2.4	3.4	Volts	
			COM'L: I _{OH} = -2.6mA	2.4	3.4		
V _{OH}	Parity Output HIGH Voltage	V _{CC} = MIN, I _{OH} = -660μA V _{IN} = V _{IH} or V _{IL}	MIL	2.5	3.4	Volts	
			COM'L	2.7	3.4		
V _{OL}	Output LOW voltage (Except Bus)	V _{CC} = MIN V _{IN} = V _{IL} or V _{IH}	I _{OL} = 4mA		0.27	0.4	Volts
			I _{OL} = 8mA		0.32	0.45	
			I _{OL} = 12mA		0.37	0.5	
V _{IH}	Input HIGH Level (Except Bus)	Guaranteed input logical HIGH for all inputs	2.0			Volts	
V _{IL}	Input LOW Level (Except Bus)	Guaranteed input logical LOW for all inputs	MIL		0.7	Volts	
			COM'L		0.8		
V _I	Input Clamp Voltage (Except Bus)	V _{CC} = MIN, I _{IN} = -18mA			-1.2	Volts	
I _{IL}	Input LOW Current (Except Bus)	V _{CC} = MAX, V _{IN} = 0.4V			-0.36	mA	
I _{IH}	Input HIGH Current (Except Bus)	V _{CC} = MAX, V _{IN} = 2.7V			20	μA	
I _I	Input HIGH Current (Except Bus)	V _{CC} = MAX, V _{IN} = 5.5V			100	μA	
I _{SC}	Output Short Circuit Current (Except Bus)	V _{CC} = MAX	-12		-65	mA	
I _{CC}	Power Supply Current	V _{CC} = MAX, All inputs = GND	Am2907	75	110	mA	
			Am2908	80	120		
I _O	Off-State Output Current (Receiver Outputs)	V _{CC} = MAX	V _O = 2.4V		20	μA	
			V _O = 0.4V		-20		

BUS INPUT/OUTPUT CHARACTERISTICS over operating temperature range

Parameters	Description	Test Conditions (Note 2)		Min	Typ (Note 1)	Max	Units	
V _{OL}	Bus Output LOW Voltage	V _{CC} = MIN	I _{OL} = 40mA		0.32	0.5	Volts	
			I _{OL} = 70mA		0.41	0.7		
			I _{OL} = 100mA		0.55	0.8		
I _O	Bus Leakage Current	V _{CC} = MAX	V _O = 0.4V			-50	μA	
			V _O = 4.5V	MIL		200		
I _{OFF}	Bus Leakage Current (Power Off)	V _O = 4.5V				100	μA	
V _{TH}	Receiver Input HIGH Threshold	Bus Enable = 2.4V	Am2907	MIL	2.4	2.0	Volts	
				COM'L	2.3	2.0		
			Am2908	MIL	1.9	1.5		
				COM'L	1.7	1.5		
V _{TL}	Receiver Input LOW Threshold	Bus Enable = 2.4V	Am2907	MIL		2.0	1.5	Volts
				COM'L		2.0	1.6	
			Am2908	MIL		1.5	1.1	
				COM'L		1.5	1.3	
V _I	Input Clamp Voltage	V _{CC} = MIN, I _{IN} = -18mA				-1.2	Volts	

5

TYPICAL PERFORMANCE CURVES

Bus Output Low Voltage Versus Ambient Temperature

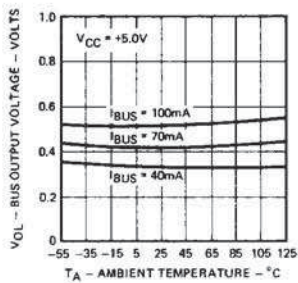

OP001340

Am2907 Receiver Threshold Variation Versus Ambient Temperature

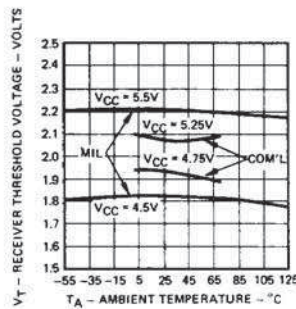

OP001330

Am2908 Receiver Threshold Variation Versus Ambient Temperature

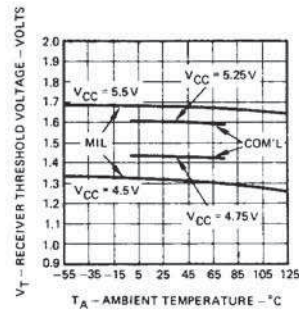

OP001420

INPUT/OUTPUT CURRENT INTERFACE CONDITIONS

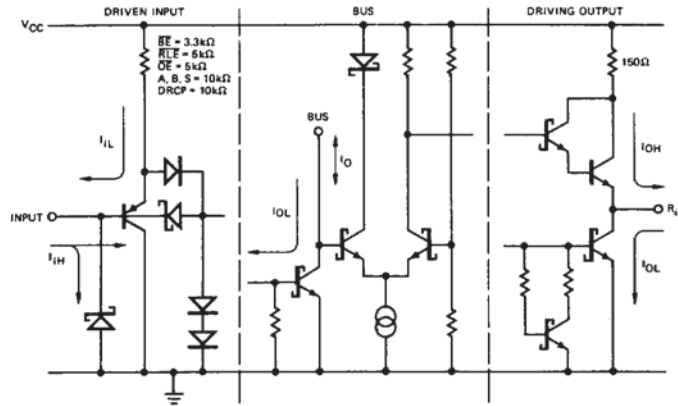

IC000390

Note: Actual current flow direction shown.

SWITCHING CHARACTERISTICS over operating range unless otherwise specified

Parameters	Description	Test Conditions	COMMERCIAL			MILITARY			Units
			Am2907			Am2907			
			Min	Typ (Note 1)	Max	Min	Typ (Note 1)	Max	
t_{PHL}	Driver Clock (DRCP) to Bus	C_L (BUS) = 50 pF R_L (BUS) = 50 Ω		21	36		21	40	ns
t_{PLH}				21	36		21	40	
t_{PHL}	Bus Enable (BE) to Bus	C_L = 15 pF R_L = 2.0 k Ω		13	23		13	26	ns
t_{PLH}				13	23		13	26	
t_s	Data Inputs		15			18			ns
t_h			7.0			8.0			
t_{PW}	Clock Pulse Width (HIGH)		25			28			ns
t_{PLH}	Bus to Receiver Output (Latch Enabled)			18	34		18	37	ns
t_{PHL}				18	34		18	37	
t_{PLH}	Latch Enable to Receiver Output			21	34		21	37	ns
t_{PHL}				21	34		21	37	
t_s	Bus to Latch Enable (ALE)		18			21			ns
t_h			5.0			7.0			
t_{PLH}	Data to Odd Parity Out (Driver Enabled)			21	36		21	40	ns
t_{PHL}				21	36		21	40	
t_{PLH}	Bus to Odd Parity Out (Driver Inhibit)			21	36		21	40	ns
t_{PHL}				21	36		21	40	
t_{PLH}	Latch Enable (ALE) to Odd Parity Output			21	36		21	40	ns
t_{PHL}				21	36		21	40	
t_{ZH}	Output Control to Output			14	25		14	28	ns
t_{ZL}				14	25		14	28	
t_{HZ}	Output Control to Output	C_L = 5.0 pF R_L = 2.0 k Ω		14	25		14	28	ns
t_{LZ}				14	25		14	28	

- Notes:
 1. Typical limits are at $V_{CC} = 5.0$ V, 25°C ambient and maximum loading.
 2. For conditions shown as MIN or MAX, use the appropriate value specified under Operating Ranges for the applicable device type.
 3. Not more than one output should be shorted at a time. Duration of the short circuit test should not exceed one second.

SWITCHING CHARACTERISTICS over operating range unless otherwise specified										
Parameters	Description	Test Conditions	COMMERCIAL			MILITARY			Units	
			Am2908			Am2908				
			Min	Typ (Note 1)	Max	Min	Typ (Note 1)	Max		
t _{PHL}	Driver Clock (DRCP) to Bus	C _L (BUS) = 50 pF R _L (BUS): 91 Ω to V _{CC} 200 Ω to GND		21	36		21	40	ns	
t _{PLH}				21	36		21	40		
t _{PHL}	Bus Enable (\overline{BE}) to Bus				13	23		13	26	ns
t _{PLH}					13	23		13	26	
t _r	Bus Output Rise Time			7	10		5	10	ns	
t _f	Bus Output Fall Time			4	6		3	6		
t _s	Data Inputs			15			18		ns	
t _h				7.0			8.0			
t _{PW}	Clock Pulse Width (HIGH)			25			28		ns	
t _{PLH}	Bus to Receiver Output (Latch Enabled)		C _L = 50 pF R _L = 2.0 kΩ		18	35		18	38	ns
t _{PHL}				18	35		18	38		
t _{PLH}	Latch Enable to Receiver Output				21	35		21	38	ns
t _{PHL}					21	35		21	38	
t _s	Bus to Latch Enable (\overline{LE})			18			21		ns	
t _h			5.0			7.0				
t _{PLH}	Data to Odd Parity Out (Driver Enabled)	C _L = 15 pF R _L = 2.0 kΩ		21	36		21	40	ns	
t _{PHL}				21	36		21	40		
t _{PLH}	Bus to Odd Parity Out (Driver Inhibit)				21	36		21	40	ns
t _{PHL}					21	36		21	40	
t _{PLH}	Latch Enable (\overline{LE}) to Odd Parity Output				21	36		21	40	ns
t _{PHL}					21	36		21	40	
t _{ZH}	Output Control to Output			14	25		14	28	ns	
t _{ZL}				14	25		14	28		
t _{HZ}	Output Control to Output	C _L = 5.0 pF R _L = 2.0 kΩ		14	25		14	28	ns	
t _{LZ}					14	25		14		28

Notes: 1. Typical limits are at V_{CC} = 5.0 V, 25°C ambient and maximum loading.
2. For conditions shown as MIN or MAX, use the appropriate value specified under Operating Ranges for the applicable device type.

SWITCHING WAVEFORMS

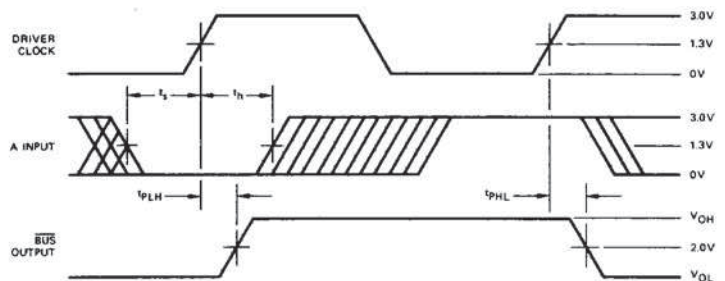

WF002430

INPUT SET-UP AND HOLD TIMES.

SWITCHING TEST CIRCUIT

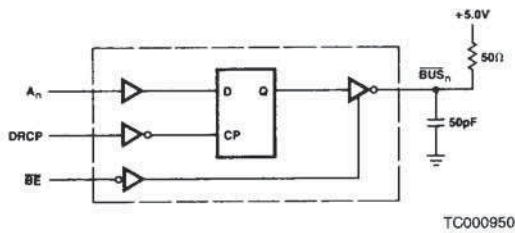

Am2907
DRIVER SWITCHING TEST CIRCUIT

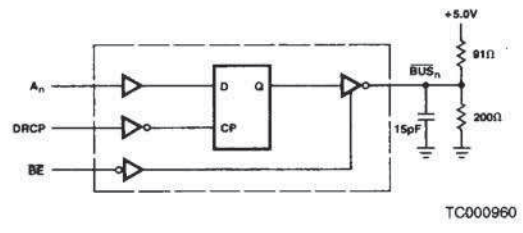

Am2908
DRIVER SWITCHING TEST CIRCUIT

SWITCHING TEST CIRCUIT

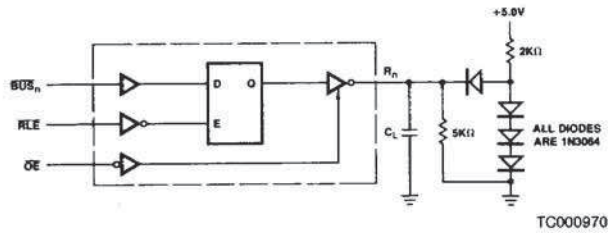

Note: C_L = 15pF for Am2907
C_L = 50pF for Am2908
Am2907/08 RECEIVER SWITCHING TEST CIRCUIT.

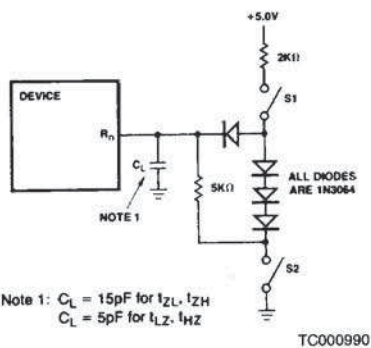

LOAD FOR RECEIVER TRI-STATE TEST

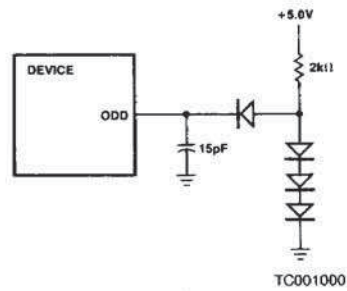

LOAD FOR PARITY OUTPUT

SWITCHING WAVEFORMS

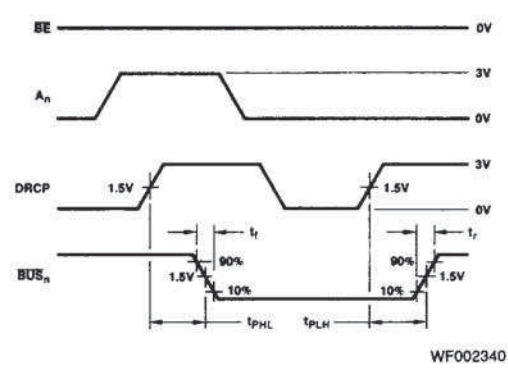

DRIVER CLOCK (DRCP) TO BUS

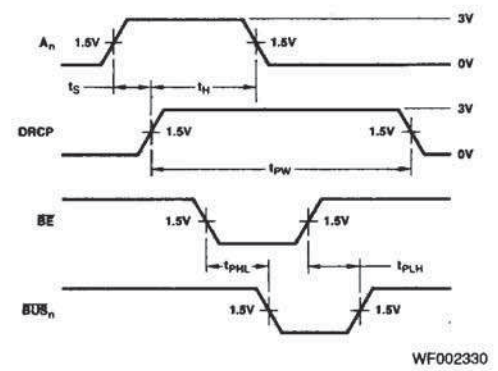

BUS ENABLE (\overline{BE}) TO BUS

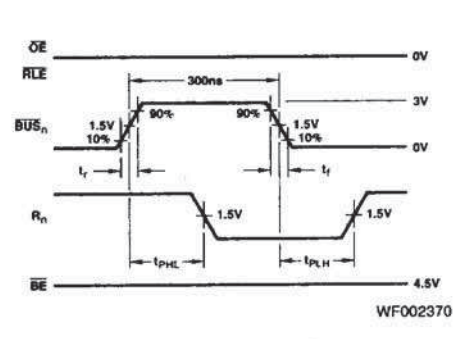

BUS TO RECEIVER OUTPUT (LATCH ENABLED)

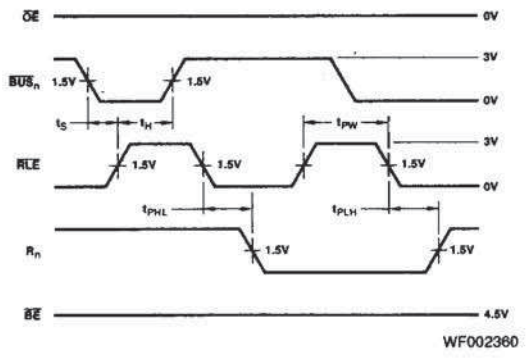

LATCH ENABLE TO RECEIVER OUTPUT

SWITCHING WAVEFORMS

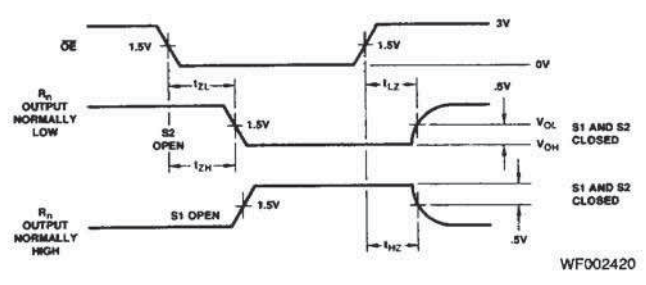

RECEIVER TRI-STATE WAVEFORMS

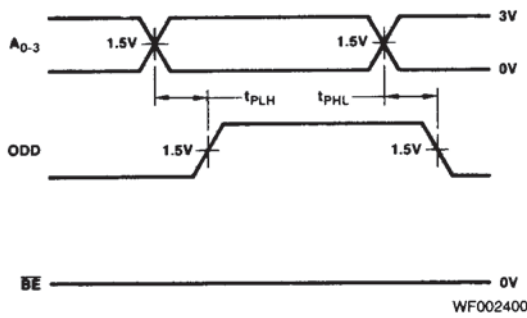

A INPUT TO PARITY OUTPUT

WF002400

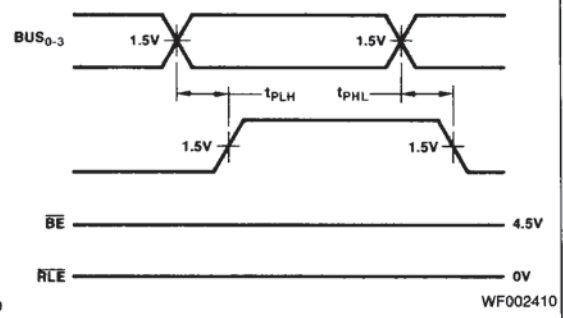

BUS TO PARITY OUTPUT

WF002410