

CA3085, CA3085A, CA3085B

Positive Voltage Regulators

The CA3085, CA3085A, and CA3085B are silicon monolithic integrated circuits designed specifically for service as voltage regulators at output voltages ranging from 1.7V to 46V at currents up to 100mA.

The CA3085A and CA3085B have output capabilities up to 100mA and the CA3085 up to 12mA without the use of external pass transistors. However, all the devices can provide voltage regulation at load currents greater than 100mA with the use of suitable external pass transistors. The CA3085 Series has an unregulated input voltage ranging from 7.5V to 30V (CA3085), 7.5V to 40V (CA3085A), and 7.5V to 50V (CA3085B) and a minimum regulated output voltage of 26V (CA3085), 36V (CA3085A), and 46V (CA3085B).

Rochester Electronics Manufactured Components

Rochester branded components are manufactured using either die/wafers purchased from the original suppliers or Rochester wafers recreated from the original IP. All recreations are done with the approval of the OCM.

Parts are tested using original factory test programs or Rochester developed test solutions to guarantee product meets or exceeds the OCM data sheet.

Quality Overview

- ISO-9001
- AS9120 certification
- Qualified Manufacturers List (QML) MIL-PRF-38535
 - Class Q Military
 - Class V Space Level
- Qualified Suppliers List of Distributors (QSLD)
 - Rochester is a critical supplier to DLA and meets all industry and DLA standards.

Rochester Electronics, LLC is committed to supplying products that satisfy customer expectations for quality and are equal to those originally supplied by industry manufacturers.

The original manufacturer's datasheet accompanying this document reflects the performance and specifications of the Rochester manufactured version of this device. Rochester Electronics guarantees the performance of its semiconductor products to the original OEM specifications. 'Typical' values are for reference purposes only. Certain minimum or maximum ratings may be based on product characterization, design, simulation, or sample testing.

CA3085, CA3085A CA3085B

Positive Voltage Regulators from
1.7V to 46V at Currents Up to 100mA

April 1994

Features

- Up to 100mA Output Current
- Input and Output Short-Circuit Protection
- Load and Line Regulation 0.025%
- Pin Compatible with LM100 Series
- Adjustable Output Voltage

Applications

- Shunt Voltage Regulator
- Current Regulator
- Switching Voltage Regulator
- High-Current Voltage Regulator
- Combination Positive and Negative Voltage Regulator
- Dual Tracking Regulator

TYPE	V _{IN} RANGE (V)	V _{OUT} RANGE (V)	MAX I _{OUT} (mA)	MAX LOAD REGULATION (%V _{OUT})
CA3085	7.5 to 30	1.8 to 26	12 (Note 1)	0.1
CA3085A	7.5 to 40	1.7 to 36	100	0.15
CA3085B	7.5 to 50	1.7 to 46	100	0.15

NOTE:

1. This value may be extended to 100mA; however, regulation is not specified beyond 12mA.

Description

The CA3085, CA3085A, and CA3085B are silicon monolithic integrated circuits designed specifically for service as voltage regulators at output voltages ranging from 1.7V to 46V at currents up to 100 milliamperes.

A block diagram of the CA3085 Series is shown. The diagram shows the connecting terminals that provide access to the regulator circuit components. The voltage regulators provide important features such as: frequency compensation, short-circuit protection, temperature-compensated reference voltage, current limiting, and booster input. These devices are useful in a wide range of applications for regulating high-current, switching, shunt, and positive and negative voltages. They are also applicable for current and dual-tracking regulation.

The CA3085A and CA3085B have output current capabilities up to 100mA and the CA3085 up to 12mA without the use of external pass transistors. However, all the devices can provide voltage regulation at load currents greater than 100mA with the use of suitable external pass transistors. The CA3085 Series has an unregulated input voltage ranging from 7.5V to 30V (CA3085), 7.5V to 40V (CA3085A), and 7.5V to 50V (CA3085B) and a minimum regulated output voltage of 26V (CA3085), 36V (CA3085A), and 46V (CA3085B).

Ordering Information

PART NUMBER	TEMPERATURE RANGE	PACKAGE
CA3085, A, B	-55°C to +125°C	8 Pin Metal Can
CA3085E, AE, BE	-55°C to +125°C	8 Lead Plastic DIP

Pinouts

CA3085, A, B, E, AE, BE (PDIP)
TOP VIEW

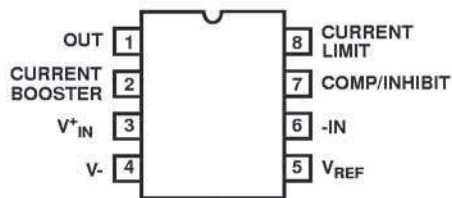

CA3085S, AS, BS (CAN)
TOP VIEW

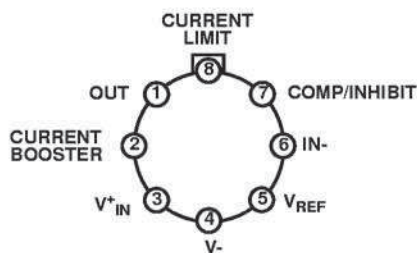

Functional Block Diagram

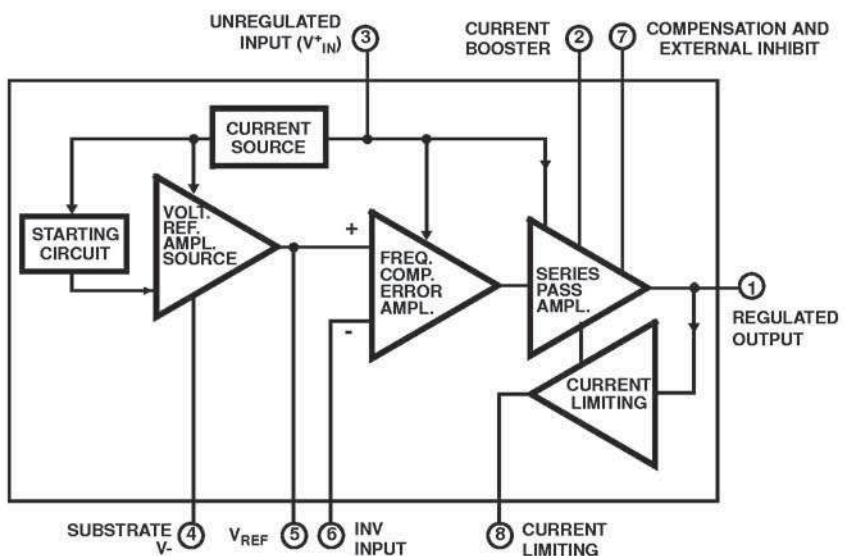

Specifications CA3085, CA3085A, CA3085B

Absolute Maximum Ratings

Supply Voltage	+7.0V
Unregulated Input Voltage	
CA3085	30V
CA3085A	40V
CA3085B	50V
Storage Temperature Range	-65°C to +150°C
Junction Temperature	+175°C
Plastic DIP Package	+150°C
Lead Temperature (Soldering 10s)	+265°C

Thermal Information

Thermal Resistance	θ_{JA}	θ_{JC}
Metal Can (Without Heat Sink)	156°C/W	68°C/W
Plastic DIP Package	155°C/W	-
Maximum Package Power Dissipation		
Plastic DIP (Without Heat Sink)		
Up to $T_A = 55^\circ\text{C}$	630mW	
Above $T_A = 55^\circ\text{C}$	Derate Linearly at 6.67mW/°C	
Metal Can (With Heat Sink)		
Up to $T_C = 55^\circ\text{C}$	1.6W	
Above $T_C = 55^\circ\text{C}$	Derate Linearly at 16.7mW/°C	

CAUTION: Stresses above those listed in "Absolute Maximum Ratings" may cause permanent damage to the device. This is a stress only rating and operation of the device at these or any other conditions above those indicated in the operational sections of this specification is not implied.

Operating Conditions

Operating Voltage Range	+1.7V to +46V	Operating Temperature Range	-55°C to +125°C
-------------------------------	---------------	-----------------------------------	-----------------

Maximum Voltage Ratings

The following chart gives the range of voltages which can be applied to the terminal listed vertically with respect to the terminals listed horizontally. For example, the voltage range between vertical Terminal Number 7 and horizontal Terminal Number 1 is +3 to -10V.

TERMINAL NUMBER	5	6	7	8	1	2	3	4
5	-	+5 -5	Note 1	Note 1	Note 1	Note 1	Note 1	+10 0
6	-	-	Note 1	Note 1	Note 1	Note 1	Note 1	Note 1
7	-	-	-	+3 -10	-103	Note 1	Note 1	+(Note 2) 0
8	-	-	-	-	+5 -1	Note 1	Note 1	Note 1
1	-	-	-	-	-	+10 -(Note 2)	0 -(Note 2)	+(Note 2) 0
2	-	-	-	-	-	-	0 -	+(Note 2) 0
3	-	-	-	-	-	-	-	+(Note 2) 0
4	-	-	-	-	-	-	-	Substrate and Case

NOTES:

- Voltages are not normally applied between these terminals; however, voltages appearing between these terminals are safe, if the specified voltage limits between all other terminals are not exceeded.
- 30V (CA3085); 40V (CA3085A); 50V (CA3085B)

Maximum Current Ratings

TERMINAL NUMBER	I_{IN} (mA)	I_{OUT} (mA)
5	10	1.0
6	1.0	-0.1
7	1.0	-0.1
8	0.1	10
1	20	150
2	150	60
3	150	60
4	-	-

Specifications CA3085, CA3085A, CA3085B

DC Electrical Specifications $T_A = +25^\circ\text{C}$, Unless Otherwise Specified

PARAMETERS	SYMBOL	TEST CONDITIONS	CA3085			CA3085A			CA3085B			UNITS	
			MIN	TYP	MAX	MIN	TYP	MAX	MIN	TYP	MAX		
DC CHARACTERISTICS													
Reference Voltage	V_{REF}	$V_{IN}^+ = 15\text{V}$ (Figure 3)	1.4	1.6	1.8	1.5	1.6	1.7	1.5	1.6	1.7	V	
Quiescent Regulator Current	$I_{quiescent}$	$V_{IN}^+ = 30\text{V}$ (Figure 3)	-	3.3	4.5	-	-	-	-	-	-	mA	
		$V_{IN}^+ = 40\text{V}$ (Figure 3)	-	-	-	-	3.65	5	-	-	-	mA	
		$V_{IN}^+ = 50\text{V}$ (Figure 3)	-	-	-	-	-	-	-	4.05	7	mA	
Input Voltage Range	$V_{IN(\text{range})}$		7.5	-	30	7.5	-	40	7.5	-	50	V	
Maximum Output Voltage	$V_{O(\text{MAX})}$	$V_{IN}^+ = 30, 40, 50\text{V}$ (Note 1); $R_L = 365\Omega$; Term. No. 6 to GND (Figure 3)	26	27	-	36	37	-	46	47	-	V	
Maximum Output Voltage	$V_{O(\text{MIN})}$	$V_{IN}^+ = 30\text{V}$ (Figure 3)	-	1.6	1.8	-	1.6	1.7	-	1.6	1.7	V	
Input - Output Voltage Differential	$V_{IN}-V_{OUT}$		4	-	28	4	-	38	3.5	-	48	V	
Limiting Current	I_{LIM}	$V_{IN}^+ = 16\text{V}$, $V_{OUT}^+ = 10\text{V}$, $R_{SCP} = 6\Omega$ (Note 2) (Figure 6)	-	96	120	-	96	120	-	96	120	mA	
Load Regulation (Note 3)		$I_L = 1$ to 100mA , $R_{SCP} = 0$	-	-	-	-	0.025	0.15	-	0.025	0.15	% V_{OUT}	
		$I_L = 1$ to 100mA , $R_{SCP} = 0$, $T_A = 0^\circ\text{C}$ to $+70^\circ\text{C}$	-	-	-	-	0.035	0.6	-	0.035	0.6	% V_{OUT}	
		$I_L = 1$ to 12mA , $R_{SCP} = 0$	-	0.003	0.1	-	-	-	-	-	-	% V_{OUT}	
Line Regulation (Note 4)		$I_L = 1\text{mA}$, $R_{SCP} = 0$	-	0.025	0.1	-	0.025	0.075	-	0.025	0.04	%/V	
		$I_L = 1\text{mA}$, $R_{SCP} = 0$, $T_A = 0^\circ\text{C}$ to $+70^\circ\text{C}$	-	0.04	0.15	-	0.04	0.1	-	0.04	0.08	%/V	
Equivalent Noise Output Voltage	V_{NOISE}	$V_{IN}^+ = 25\text{V}$ (Figure 10)	$C_{REF} = 0$	-	0.5	-	-	0.5	-	-	0.5	-	mVp-p
			$C_{REF} = 0.22\mu\text{F}$	-	0.3	-	-	0.3	-	-	0.3	-	mVp-p
Ripple Rejection		$V_{IN}^+ = 25\text{V}$, $f = 1\text{kHz}$ (Figure 11)	$C_{REF} = 0$	-	50	-	-	50	-	45	50	-	dB
			$C_{REF} = 2\mu\text{F}$	-	56	-	-	56	-	50	56	-	dB
Output Resistance	r_O	$V_{IN}^+ = 25\text{V}$, $f = 1\text{kHz}$ (Figure 11)	-	0.075	1.1	-	0.075	0.3	-	0.075	0.3	Ω	
Temperature Coefficient of Reference and Output Voltages	V_{REF}, V_O (Note 4)	$I_L = 0$, $V_{REF} = 1.6\text{V}$	-	0.0035	-	-	0.0035	-	-	0.0035	-	%/ $^\circ\text{C}$	

Specifications CA3085, CA3085A, CA3085B

DC Electrical Specifications $T_A = +25^\circ\text{C}$, Unless Otherwise Specified (Continued)

PARAMETERS	SYMBOL	TEST CONDITIONS	CA3085			CA3085A			CA3085B			UNITS
			MIN	TYP	MAX	MIN	TYP	MAX	MIN	TYP	MAX	
LOAD TRANSIENT RECOVERY TIME												
Turn On	t_{ON}	$V_{IN}^+ = 25\text{V}$, +50mA Step (Figure 16)	-	1	-	-	1	-	-	1	-	μs
Turn Off	t_{OFF}	$V_{IN}^+ = 25\text{V}$, -50mA Step (Figure 16)	-	3	-	-	3	-	-	3	-	μs
LOAD TRANSIENT RECOVERY TIME												
Turn On	t_{ON}	$V_{IN}^+ = 25\text{V}$, $f = 1\text{kHz}$, 2V Step	-	0.8	-	-	0.8	-	-	0.8	-	μs
Turn Off	t_{OFF}		-	0.4	-	-	0.4	-	-	0.4	-	μs

NOTES:

- 30V (CA3085), 40V (CA3085A), 50V (CA3085B)
- R_{SCP} : Short Circuit Protection Resistance
- Load Regulation = $[\Delta V_{OUT} \div V_{OUT}(\text{initial})] \times 100\%$
- Line Regulation = $[\Delta V_{OUT} \div V_{OUT}(\text{initial})(\Delta V_{IN})] \times 100\%$

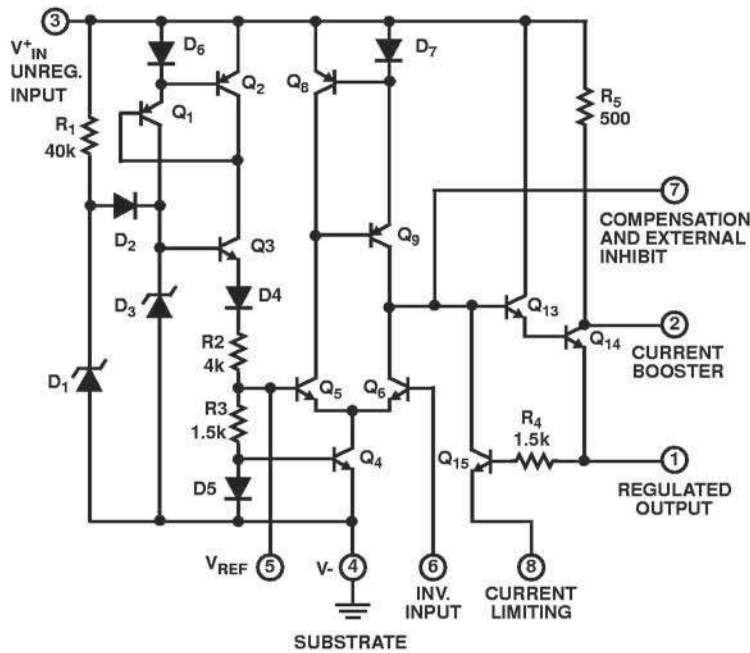

All Resistance Values are in Ohms

FIGURE 1. SCHEMATIC DIAGRAM OF CA3085 SERIES

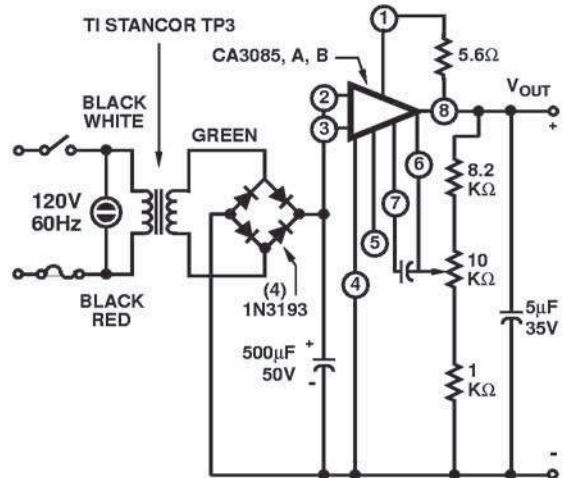

$V_{OUT} = 3.5\text{V to } 20\text{V}$ (0 to 90mA)
 Regulation = 0.2% (Line and Load)
 Ripple < 0.5mV at Full Load

FIGURE 2. APPLICATION OF THE CA3085 SERIES IN A TYPICAL POWER SUPPLY

Test Circuits and Typical Performance Curves

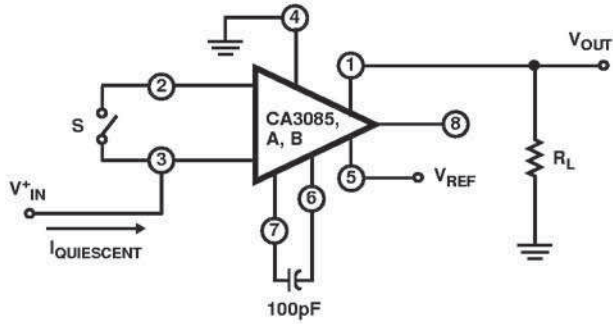

TEST	RL	VIN	CONNECT TERM NO. 6	S
VREF	∞	+1.6	Open	Open
IQUIESCENT	∞	+40	Open	Open
VOUT(MAX)	365Ω	+40	Ground	Closed
VOUT(MIN)	10k	+30	Terminal No.1	Open

FIGURE 3. TEST CIRCUIT FOR VREF, IQUIESCENT, VOUT(MAX), VOUT(MIN)

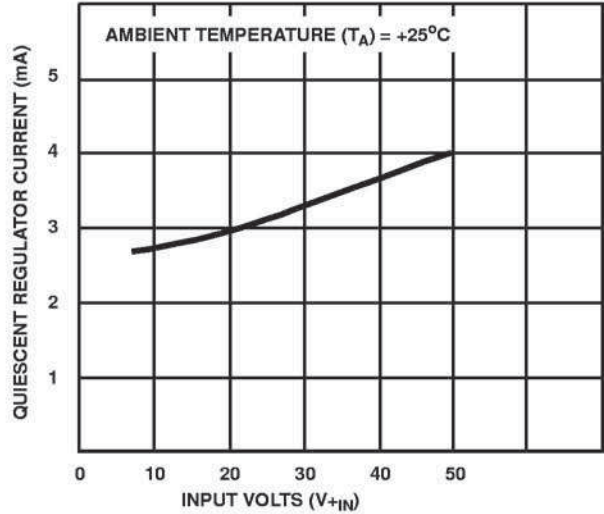

FIGURE 4. IQUIESCENT vs VIN

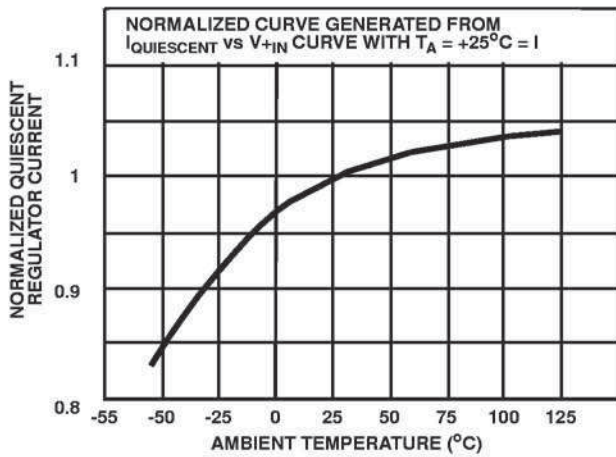
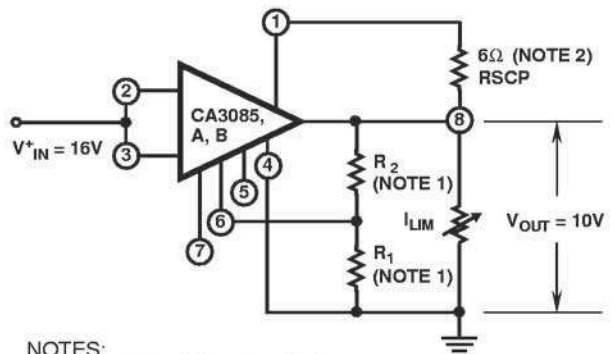

FIGURE 5. NORMALIZED IQUIESCENT vs TA



- NOTES:
 1. $V_{OUT} = 1.6 \times (R_1 + R_2 \div R_1)$
 2. The limits current is inversely proportional to R_{SCP}

FIGURE 6. TEST CIRCUIT FOR LIMITING CURRENT

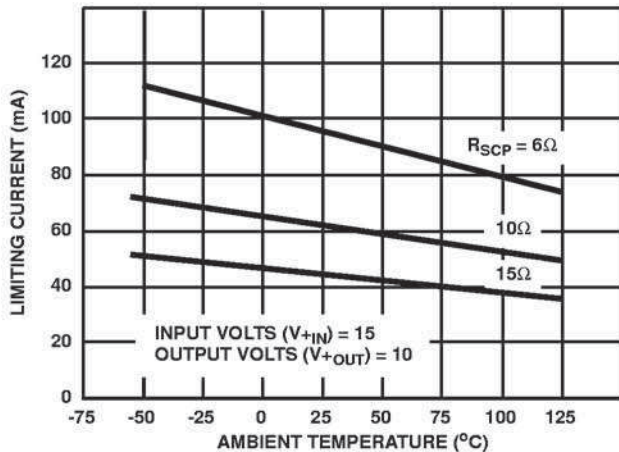

FIGURE 7. ILIM vs TA

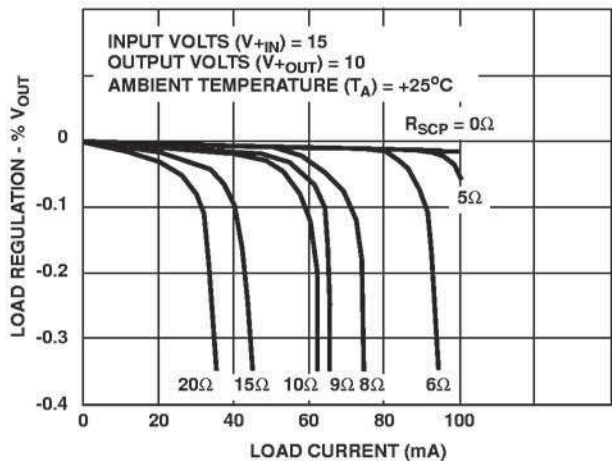

FIGURE 8. LOAD REGULATION CHARACTERISTICS

Test Circuits and Typical Performance Curves (Continued)

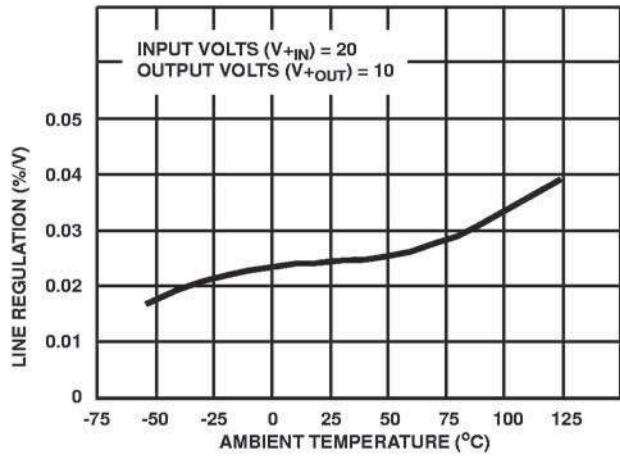

FIGURE 9. LINE REGULATION TEMPERATURE CHARACTERISTICS

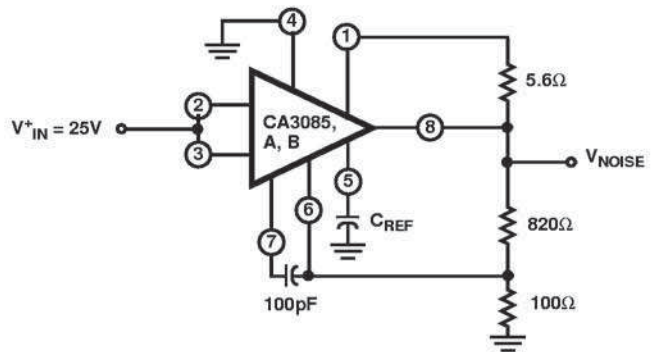

FIGURE 10. TEST CIRCUIT FOR NOISE VOLTAGE

TEST PROCEDURES FOR TEST CIRCUIT FOR RIPPLE REJECTION AND OUTPUT RESISTANCE

Output Resistance

Conditions

1. $V_{IN} = +25V$, $C_{REF} = 0$, Short E_1
2. Set E_{S2} at 1kHz so that $E_2 = 4V_{RMS}$
3. Read V_{OUT} on a VTVM, such as a Hewlett-Packard, HP400D or Equivalent
4. Calculate R_{OUT} from $R_{OUT} = V_{OUT}(R_L/E_2)$

Ripple Rejection - I

Conditions

1. $V_{IN} = +25V$, $C_{REF} = 0$, Short E_2
2. Set E_{S1} at 1kHz so that $E_1 = 3V_{RMS}$
3. Read V_{OUT} on a VTVM, such as a Hewlett-Packard, HP400D or Equivalent
4. Calculate Ripple Rejection from $20 \log (E_1/V_{OUT})$

Ripple Rejection - II

Conditions

1. Repeat Ripple Rejection I with $C_{REF} = 2\mu F$

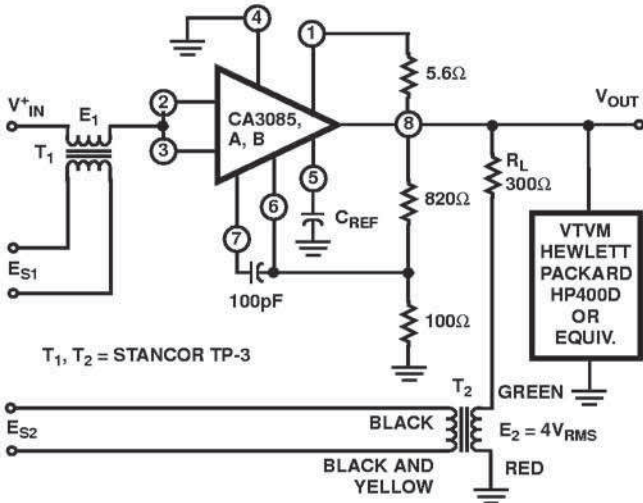

FIGURE 11. TEST CIRCUIT FOR RIPPLE REJECTION AND OUTPUT RESISTANCE

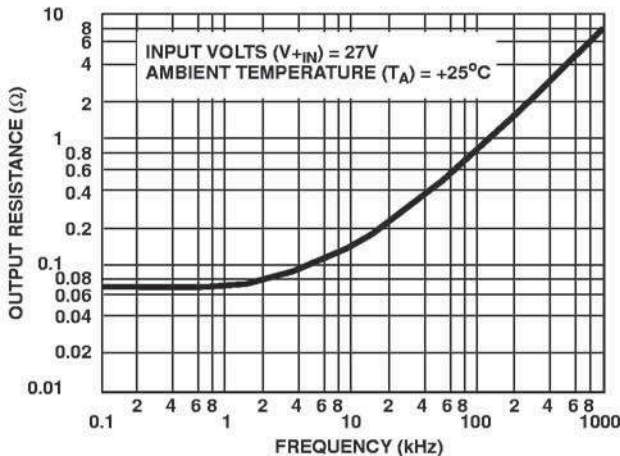

FIGURE 12. r_O vs f

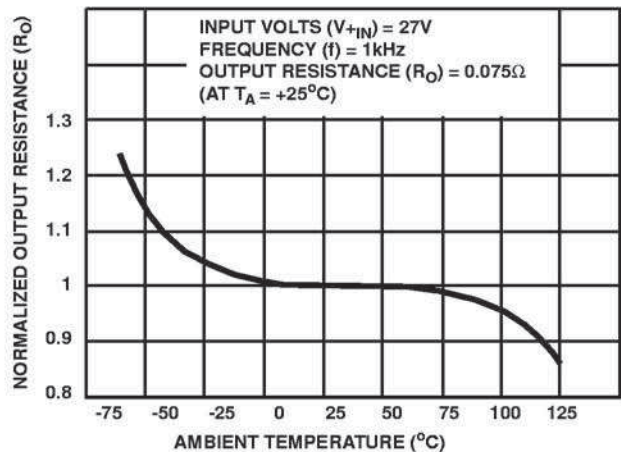

FIGURE 13. NORMALIZED r_O vs T_A

Test Circuits and Typical Performance Curves (Continued)

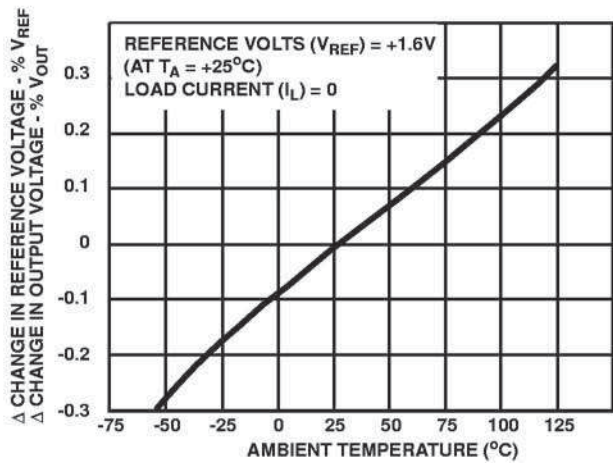

FIGURE 14. TEMPERATURE COEFFICIENT OF V_{REF} AND V_{OUT}

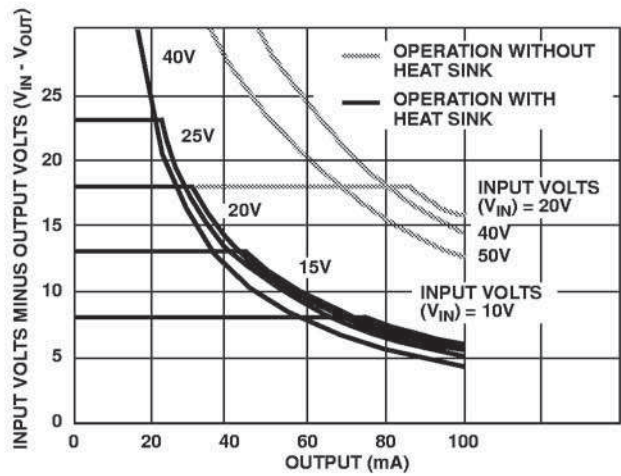

FIGURE 15. DISSIPATION LIMITATION ($V_{IN} - V_{OUT}$ vs I_{OUT})

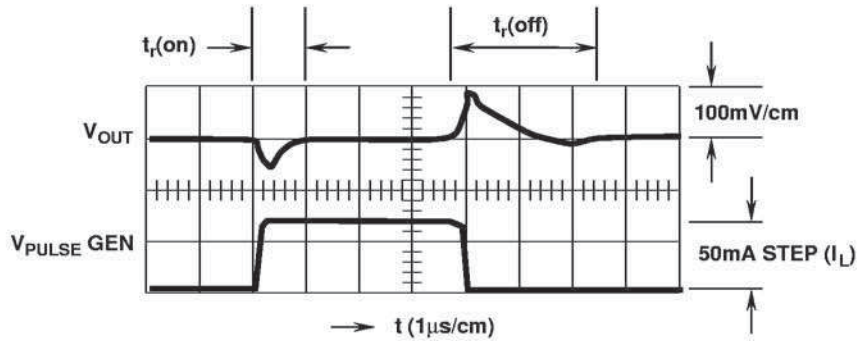
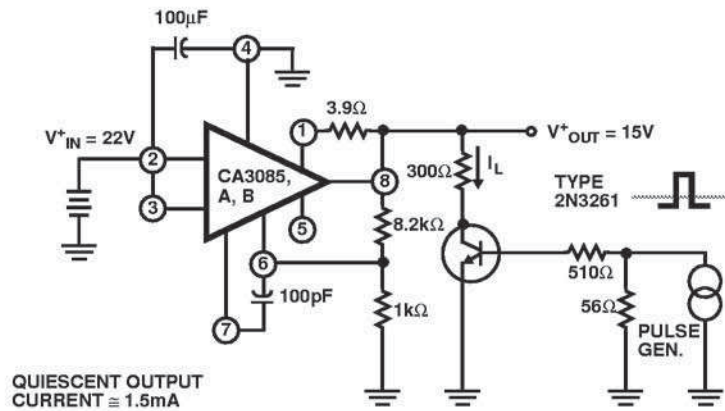

FIGURE 16. TURN-ON AND TURN-OFF RECOVERY TIME TEST CIRCUIT WITH ASSOCIATED WAVEFORMS

See Application Note AN6157 for further information

Typical Regulator Circuits

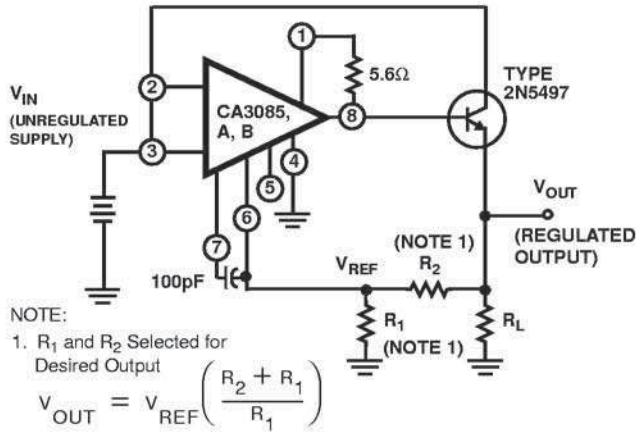
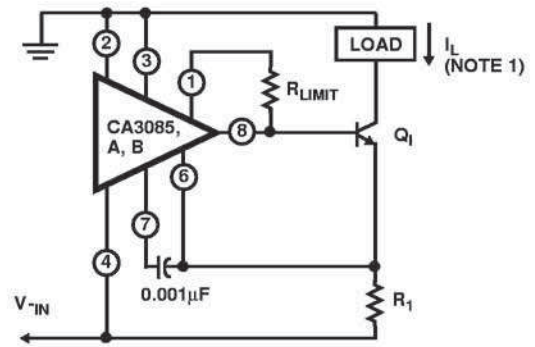

FIGURE 17. TYPICAL HIGH CURRENT VOLTAGE REGULATOR CIRCUIT



Q_1 : Any N-P-N Silicon Transistor that can handle a 2A Load Current such as 2N3772 or Equivalent

NOTE

- $I_L = 1.6 \div R_1$, $200\mu A \leq I_L \leq 2A$

FIGURE 18. TYPICAL CURRENT REGULATOR CIRCUIT

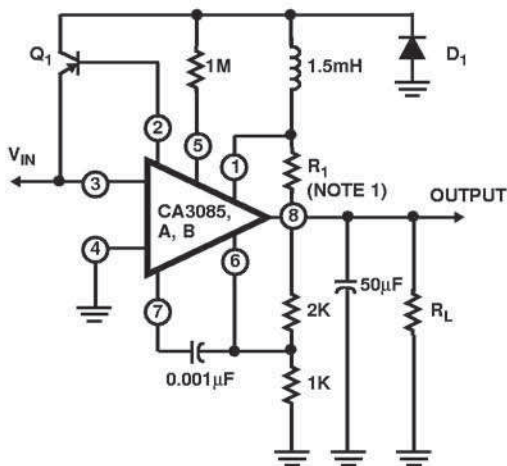

All Resistance Values are in Ohms

D_1 : 1N4001 or Equivalent

Q_1 : 2N5322 or Equivalent

NOTE:

- $R_1 = 0.7 I_L$ (Max)

FIGURE 19. TYPICAL SWITCHING REGULATOR CIRCUIT

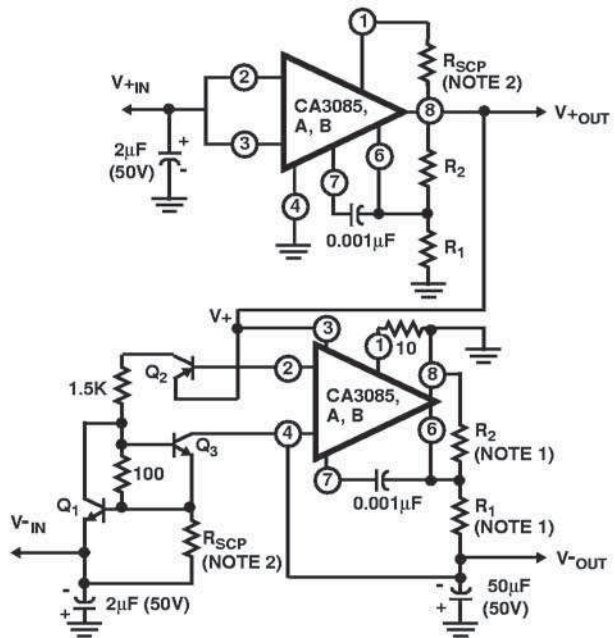

All Resistance Values are in Ohms

Q_1 : 2N2102 or Equivalent

Q_2 : Any P-N-P Silicon Transistor (2N5322 or Equivalent)

Q_3 : Any N-P-N Silicon Transistor that can handle the desired Load Current (2N3772 or Equivalent)

NOTE:

- $V_{OUT} = (R_1 + R_2) \div R_1$
- R_{SCP} : Short Circuit Protection Resistance

FIGURE 20. COMBINATION POSITIVE AND NEGATIVE VOLTAGE REGULATOR CIRCUIT