

LM3916

Dot/Bar Display Driver

The LM3916 is a monolithic integrated circuit that senses analog voltage levels and drives ten LEDs, LCDs or vacuum fluorescent displays, providing an electronic version of the popular VU meter. One pin changes the display from a bar graph to a moving dot display. LED current drive is regulated and programmable, eliminating the need for current limiting resistors. The whole display system can operate from a single supply as low as 3V or as high as 25V.

The IC contains an adjustable voltage reference and an accurate ten-step voltage divider. The high-impedance input buffer accepts signals down to ground and up to within 1.5V of the positive supply. Further, it needs no protection against inputs of $\pm 35V$. The input buffer drives 10 individual comparators referenced to the precision divider. Accuracy is typically better than 0.2 dB.

Rochester Electronics Manufactured Components

Rochester branded components are manufactured using either die/wafers purchased from the original suppliers or Rochester wafers recreated from the original IP. All recreations are done with the approval of the OCM.

Parts are tested using original factory test programs or Rochester developed test solutions to guarantee product meets or exceeds the OCM data sheet.

Quality Overview

- ISO-9001
- AS9120 certification
- Qualified Manufacturers List (QML) MIL-PRF-38535
 - Class Q Military
 - Class V Space Level
- Qualified Suppliers List of Distributors (QSLD)
 - Rochester is a critical supplier to DLA and meets all industry and DLA standards.

Rochester Electronics, LLC is committed to supplying products that satisfy customer expectations for quality and are equal to those originally supplied by industry manufacturers.

The original manufacturer's datasheet accompanying this document reflects the performance and specifications of the Rochester manufactured version of this device. Rochester Electronics guarantees the performance of its semiconductor products to the original OEM specifications. 'Typical' values are for reference purposes only. Certain minimum or maximum ratings may be based on product characterization, design, simulation, or sample testing.

LM3916

Dot/Bar Display Driver

General Description

The LM3916 is a monolithic integrated circuit that senses analog voltage levels and drives ten LEDs, LCDs or vacuum fluorescent displays, providing an electronic version of the popular VU meter. One pin changes the display from a bar graph to a moving dot display. LED current drive is regulated and programmable, eliminating the need for current limiting resistors. The whole display system can operate from a single supply as low as 3V or as high as 25V.

The IC contains an adjustable voltage reference and an accurate ten-step voltage divider. The high-impedance input buffer accepts signals down to ground and up to within 1.5V of the positive supply. Further, it needs no protection against inputs of $\pm 35V$. The input buffer drives 10 individual comparators referenced to the precision divider. Accuracy is typically better than 0.2 dB.

Audio applications include average or peak level indicators, and power meters. Replacing conventional meters with an LED bar graph results in a faster responding, more rugged display with high visibility that retains the ease of interpretation of an analog display.

The LM3916 is extremely easy to apply. A 1.2V full-scale meter requires only one resistor in addition to the ten LEDs. One more resistor programs the full-scale anywhere from 1.2V to 12V independent of supply voltage. LED brightness is easily controlled with a single pot.

The LM3916 is very versatile. The outputs can drive LCDs, vacuum fluorescents and incandescent bulbs as well as LEDs of any color. Multiple devices can be cascaded for a dot or bar mode display for increased range and/or resolution. Useful in other applications are the linear LM3914 and the logarithmic LM3915.

Features

- Fast responding electronic VU meter
- Drives LEDs, LCDs, or vacuum fluorescents
- Bar or dot display mode externally selectable by user
- Expandable to displays of 70 dB
- Internal voltage reference from 1.2V to 12V
- Operates with single supply of 3V to 25V
- Inputs operate down to ground
- Output current programmable from 1 mA to 30 mA
- Input withstands $\pm 35V$ without damage or false outputs
- Outputs are current regulated, open collectors
- Directly drives TTL or CMOS
- The internal 10-step divider is floating and can be referenced to a wide range of voltages

The LM3916 is rated for operation from 0°C to +70°C. The LM3916N is available in an 18-lead molded DIP package.

Typical Applications

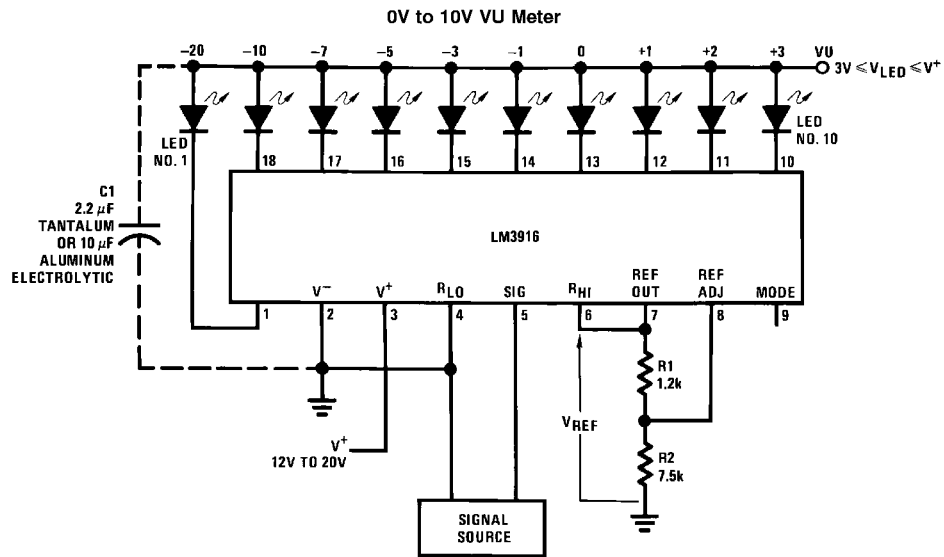

DS007971-1

$$V_{REF} = 1.25V \left(1 + \frac{R_2}{R_1} \right) + R_2 \times 80 \mu A$$

$$I_{LED} = \frac{12.5V}{R_1} + \frac{V_{REF}}{2.2 k\Omega}$$

Notes: Capacitor C1 is required if leads to the LED supply are 6" or longer.

Circuit as shown is wired for dot mode. For bar mode, connect pin 9 to pin 3. V_{LED} must be kept below 7V or dropping resistor should be used to limit IC power dissipation.

Absolute Maximum Ratings (Note 1)

If Military/Aerospace specified devices are required, please contact the National Semiconductor Sales Office/Distributors for availability and specifications.

Power Dissipation (Note 6)

Molded DIP (N) 1365 mW
Supply Voltage 25V

Voltage on Output Drivers 25V

Input Signal Overvoltage (Note 4) $\pm 35V$

Divider Voltage $-100\text{ mV to }V^+$

Reference Load Current 10 mA

Storage Temperature Range $-55^\circ\text{C to }+150^\circ\text{C}$

Lead Temperature (Soldering, 10 seconds) 260°C

Electrical Characteristics (Notes 2, 4)

Parameter	Conditions (Note 2)	Min	Typ	Max	Units
COMPARATORS					
Offset Voltage, Buffer and First Comparator	$0V \leq V_{RLO} = V_{RHI} \leq 12V$, $I_{LED} = 1\text{ mA}$		3	10	mV
Offset Voltage, Buffer and Any Other Comparator	$0V \leq V_{RLO} = V_{RHI} \leq 12V$, $I_{LED} = 1\text{ mA}$		3	15	mV
Gain ($\Delta I_{LED} / \Delta V_{IN}$)	$I_{(REF)} = 2\text{ mA}$, $I_{LED} = 10\text{ mA}$	3	8		mA/mV
Input Bias Current (at Pin 5)	$0V \leq V_{IN} \leq (V^+ - 1.5V)$		25	100	nA
Input Signal Overvoltage	No Change in Display	-35		35	V
VOLTAGE DIVIDER					
Divider Resistance	Total, Pin 6 to 4	8	12	17	k Ω
Relative Accuracy (Input Change Between Any Two Threshold Points)	(Note 3) $-1\text{ dB} \leq V_{IN} \leq 3\text{ dB}$ $-7\text{ dB} \leq V_{IN} \leq -1\text{ dB}$ $-10\text{ dB} \leq V_{IN} \leq -7\text{ dB}$	0.75 1.5 2.5	1.0 2.0 3.0	1.25 2.5 2.5	dB
Absolute Accuracy	(Note 3) $V_{IN} = 2, 1, 0, -1\text{ dB}$ $V_{IN} = -3, -5\text{ dB}$ $V_{IN} = -7, -10, -20\text{ dB}$	-0.25 -0.5 -1		+0.25 +0.5 +1	dB
VOLTAGE REFERENCE					
Output Voltage	$0.1\text{ mA} \leq I_{L(REF)} \leq 4\text{ mA}$, $V^+ = V_{LED} = 5Vg$	1.2	1.28	1.34	V
Line Regulation	$3V \leq V^+ \leq 18V$		0.01	0.03	%/V
Load Regulation	$0.1\text{ mA} \leq I_{L(REF)} \leq 4\text{ mA}$, $V^+ = V_{LED} = 5V$		0.4	2	%
Output Voltage Change with Temperature	$0^\circ\text{C} \leq T_A \leq +70^\circ\text{C}$, $I_{L(REF)} = 1\text{ mA}$, $V^+ = V_{LED} = 5V$		1		%
Adjust Pin Current			75	120	μA
OUTPUT DRIVERS					
LED Current	$V^+ = V_{LED} = 5V$, $I_{L(REF)} = 1\text{ mA}$	7	10	13	mA
LED Current Difference (Between Largest and Smallest LED Currents)	$V_{LED} = 5V$, $I_{LED} = 2\text{ mA}$ $V_{LED} = 5V$, $I_{LED} = 20\text{ mA}$		0.12 1.2	0.4 3	mA
LED Current Regulation	$2V \leq V_{LED} \leq 17V$ $I_{LED} = 2\text{ mA}$ $I_{LED} = 20\text{ mA}$		0.1 1	0.25 3	mA
Dropout Voltage	$I_{LED(ON)} = 20\text{ mA @ }V_{LED} = 5V$, $\Delta I_{LED} = 2\text{ mA}$			1.5	V
Saturation Voltage	$I_{LED} = 2.0\text{ mA}$, $I_{L(REF)} = 0.4\text{ mA}$		0.15	0.4	V
Output Leakage, Each Collector	Bar Mode (Note 5)		0.1	100	μA
Output Leakage	Dot Mode (Note 5)				
Pins 10–18			0.1	100	μA
Pin 1		60	150	450	μA

Electrical Characteristics (Notes 2, 4) (Continued)

Parameter	Conditions (Note 2)	Min	Typ	Max	Units
SUPPLY CURRENT					
Standby Supply Current (All Outputs Off)	$V^+ = +5V, I_{L(REF)} = 0.2\text{ mA}$		2.4	4.2	mA
	$V^+ = +20V, I_{L(REF)} = 1.0\text{ mA}$		6.1	9.2	mA

Note 1: Absolute Maximum Ratings indicate limits beyond which damage to the device may occur. Operating ratings indicate conditions for which the device is functional, but do not guarantee specific performance limits. Electrical Characteristics state DC and AC electrical specifications under particular test conditions which guarantee specific performance limits. This assumes that the device is within the Operating Ratings. Specifications are not guaranteed for parameters where no limit is given, however, the typical value is a good indication of device performance.

Note 2: Unless otherwise stated, all specifications apply with the following conditions:

$$3 V_{DC} \leq V^+ \leq 20 V_{DC} \quad -0.015V \leq V_{RLO} \leq 12 V_{DC} \quad T_A = 25^\circ\text{C}, I_{L(REF)} = 0.2\text{ mA}, \text{ pin 9 connected to pin 3 (bar mode).}$$

$$3 V_{DC} \leq V_{LED} \leq V^+ \quad V_{REF}, V_{RHI}, V_{RLO} \leq (V^+ - 1.5V) \quad \text{For higher power dissipations, pulse testing is used.}$$

$$-0.015V \leq V_{RHI} \leq 12 V_{DC} \quad 0V \leq V_{IN} \leq V^+ - 1.5V$$

Note 3: Accuracy is measured referred to $+3\text{ dB} = +10,000 V_{DC}$ at pin 5, with $+10,000 V_{DC}$ at pin 6, and $0.000 V_{DC}$ at pin 4. At lower full-scale voltages, buffer and comparator offset voltage may add significant error. See table for threshold voltages.

Note 4: Pin 5 input current must be limited to $\pm 3\text{ mA}$. The addition of a $39k$ resistor in series with pin 5 allows $\pm 100V$ signals without damage.

Note 5: Bar mode results when pin 9 is within 20 mV of V^+ . Dot mode results when pin 9 is pulled at least 200 mV below V^+ . LED #10 (pin 10 output current) is disabled if pin 9 is pulled $0.9V$ or more below V_{LED} .

Note 6: The maximum junction temperature of the LM3916 is 100°C . Devices must be derated for operation at elevated temperatures. Junction to ambient thermal resistance is 55°C/W for the molded DIP (N package).

LM3916 Threshold Voltage (Note 3)

dB	Volts			dB	Volts		
	Min	Typ	Max		Min	Typ	Max
3	9.985	10.000	10.015	$-3 \pm 1/2$	4.732	5.012	5.309
$2 \pm 1/4$	8.660	8.913	9.173	$-5 \pm 1/2$	3.548	3.981	4.467
$1 \pm 1/4$	7.718	7.943	8.175	-7 ± 1	2.818	3.162	3.548
$0 \pm 1/4$	6.879	7.079	7.286	-10 ± 1	1.995	2.239	2.512
$-1 \pm 1/2$	5.957	6.310	6.683	-20 ± 1	0.631	0.708	0.794

Typical Performance Characteristics

Supply Current vs Temperature

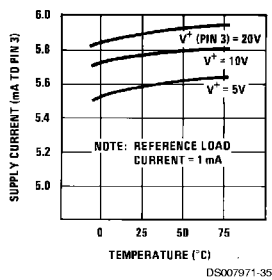

Operating Input Bias Current vs Temperature

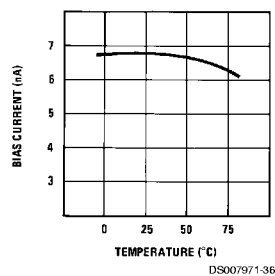

Reference Voltage vs Temperature

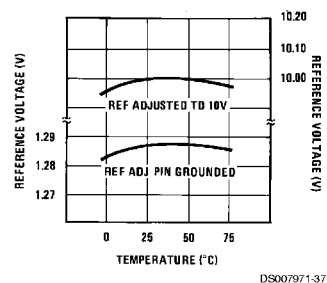

Typical Performance Characteristics (Continued)

Reference Adjust Pin Current vs Temperature

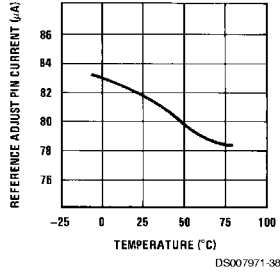

LED Current-Regulation Dropout

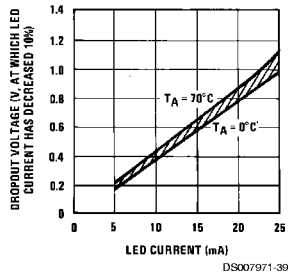

LED Driver Saturation Voltage

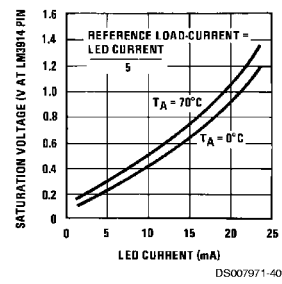

Input Current Beyond Signal Range (Pin 5)

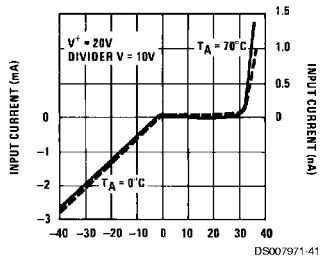

LED Current vs Referenced Loading

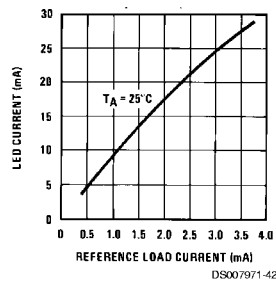

LED Driver Current Regulation

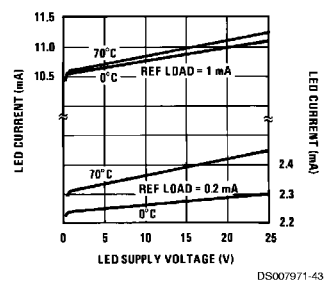

Total Divider Resistance vs Temperature

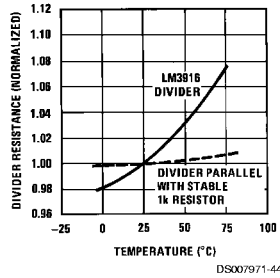

Common-Mode Limits

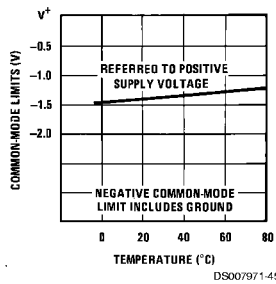

Output Characteristics

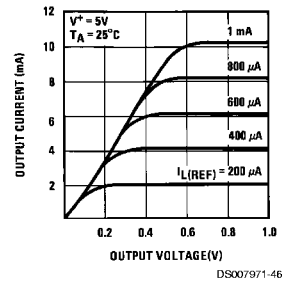

Block Diagram (Showing Simplest Application)

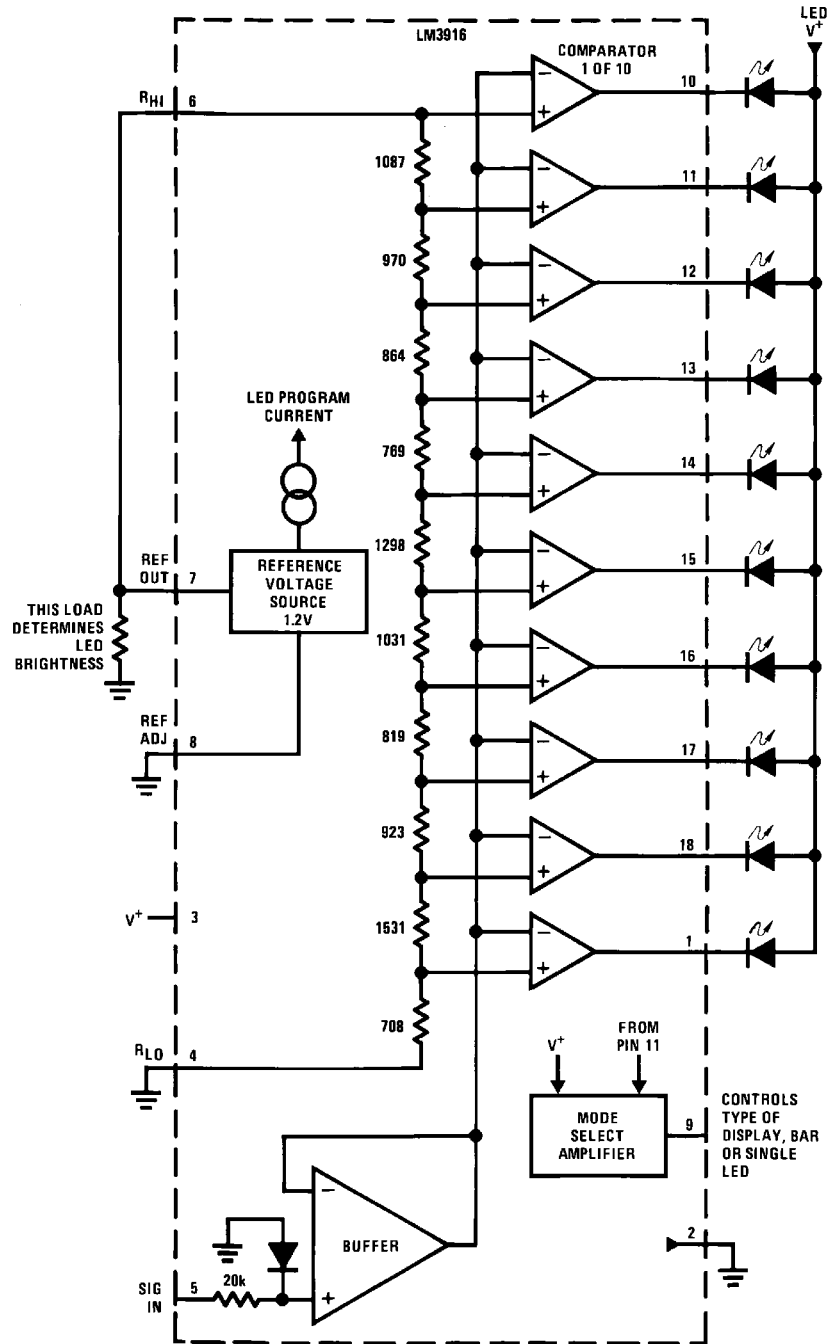

DS007971-4

Functional Description

The simplified LM3916 block diagram is included to give the general idea of the circuit's operation. A high input impedance buffer operates with signals from ground to 12V, and is protected against reverse and overvoltage signals. The signal is then applied to a series of 10 comparators; each of which is biased to a different comparison level by the resistor string.

In the example illustrated, the resistor string is connected to the internal 1.25V reference voltage. As the input voltage varies from 0 to 1.25, the comparator outputs are driven low one by one, switching on the LED indicators. The resistor divider can be connected between any 2 voltages, providing that they are at least 1.5V below V⁺ and no lower than V⁻.

INTERNAL VOLTAGE REFERENCE

The reference is designed to be adjustable and develops a nominal 1.25V between the REF OUT (pin 7) and REF ADJ (pin 8) terminals. The reference voltage is impressed across program resistor R1 and, since the voltage is constant, a constant current I₁ then flows through the output set resistor R2 giving an output voltage of:

$$V_{OUT} = V_{REF} \left(1 + \frac{R_2}{R_1} \right) + I_{ADJ} R_2$$

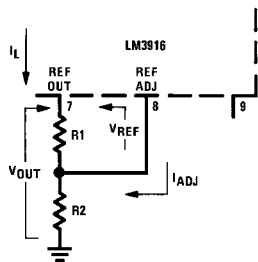

DS007971-5

Since the 120 μA current (max) from the adjust terminal represents an error term, the reference was designed to minimize changes of this current with V⁺ and load changes. For correct operation, reference load current should be between 80 μA and 5 mA. Load capacitance should be less than 0.05 μF.

CURRENT PROGRAMMING

A feature not completely illustrated by the block diagram is the LED brightness control. The current drawn out of the reference voltage pin (pin 7) determines LED current. Approximately 10 times this current will be drawn through each lighted LED, and this current will be relatively constant despite supply voltage and temperature changes. Current drawn by the internal 10-resistor divider, as well as by the external current and voltage-setting divider should be included in calculating LED drive current. The ability to modulate LED brightness with time, or in proportion to input voltage and other signals can lead to a number of novel displays or ways of indicating input overvoltages, alarms, etc.

The LM3916 outputs are current-limited NPN transistors as shown below. An internal feedback loop regulates the transistor drive. Output current is held at about 10 times the reference load current, independent of output voltage and processing variables, as long as the transistor is not saturated.

LM3916 Output Circuit

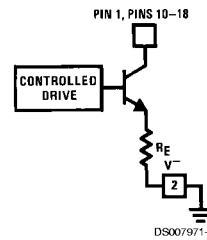

DS007971-6

Outputs may be run in saturation with no adverse effects, making it possible to directly drive logic. The effective saturation resistance of the output transistors, equal to R_E plus the transistors' collector resistance, is about 50Ω. It's also possible to drive LEDs from rectified AC with no filtering. To avoid oscillations, the LED supply should be bypassed with a 2.2 μF tantalum or 10 μF aluminum electrolytic capacitor.

MODE PIN USE

Pin 9, the Mode Select input, permits chaining of multiple devices, and controls bar or dot mode operation. The following tabulation shows the basic ways of using this input. Other more complex uses will be illustrated in the applications.

Bar Graph Display: Wire Mode Select (pin 9) directly to pin 3 (V⁺ pin).

Dot Display, Single LM3916 Driver: Leave the Mode Select pin open circuit.

Dot Display, 20 or More LEDs: Connect pin 9 of the *first* drivers in the series (i.e., the one with the lowest input voltage comparison points) to pin 1 of the next higher LM3916 driver. Continue connecting pin 9 of *lower* input drivers to pin 1 of higher input drivers for 30 or more LED displays. The last LM3916 driver in the chain will have pin 9 left open. All previous drivers should have a 20k resistor in parallel with LED #9 (pin 11 to V_{LED}).

Mode Pin Functional Description

This pin actually performs two functions. Refer to the simplified block diagram below.

Block Diagram of Mode Pin Function

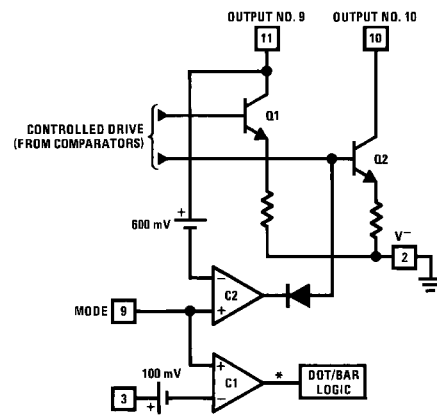

DS007971-7

*High for bar

Mode Pin Functional Description

(Continued)

DOT OR BAR MODE SELECTION

The voltage at pin 9 is sensed by comparator C1, nominally referenced to ($V^+ - 100\text{ mV}$). The chip is in bar mode when pin 9 is above this level; otherwise it's in dot mode. The comparator is designed so that pin 9 can be left open circuit for dot mode.

Taking into account comparator gain and variation in the 100 mV reference level, pin 9 should be no more than 20 mV below V^+ for bar mode and more than 200 mV below V^+ (or open circuit) for dot mode. In most applications, pin 9 is either open (dot mode) or tied to V^+ (bar mode). In bar mode, pin 9 should be connected directly to pin 3. Large currents drawn from the power supply (LED current, for example) should not share this path so that large IR drops are avoided.

DOT MODE CARRY

In order for display to make sense when multiple drivers are cascaded in dot mode, special circuitry has been included to shut off LED #10 of the first device when LED #1 of the second device comes on. The connection for cascading in dot mode has already been described and is depicted in *Figure 1*.

As long as the input signal voltage is below the threshold of the second driver, LED #11 is off. Pin 9 of driver #1 thus sees effectively an open circuit so the chip is in dot mode. As soon

as the input voltage reaches the threshold of LED #11, pin 9 of driver #1 is pulled an LED drop (1.5V or more) below V_{LED} . This condition is sensed by comparator C2, referenced 600 mV below V_{LED} . This forces the output of C2 low, which shuts off output transistor Q2, extinguishing LED #10.

V_{LED} is sensed via the 20k resistor connected to pin 11. The very small current (less than 100 μA) that is diverted from LED #9 does not noticeably affect its intensity.

An auxiliary current source at pin 1 keeps at least 100 μA flowing through LED #11 even if the input voltage rises high enough to extinguish the LED. This ensures that pin 9 of driver #1 is held low enough to force LED #10 off when *any* higher LED is illuminated. While 100 μA does not normally produce significant LED illumination, it may be noticeable when using high-efficiency LEDs in a dark environment. If this is bothersome, the simple cure is to shunt LED #11 (and LED #1) with a 10k resistor. The 1V 1R drop is more than the 900 mV worst case required to hold off LED #10 yet small enough that LED #11 does not conduct significantly.

In some circuits a number of outputs on the higher device are not used. Examples include the high resolution VU meter and the expanded range VU meter circuits (see Typical Applications). To provide the proper carry sense voltage in dot mode, the LEDs of the higher driver IC are tied to V_{LED} through two series-connected diodes as shown in *Figure 2*. Shunting the diodes with a 1k resistor provides a path for driver leakage current.

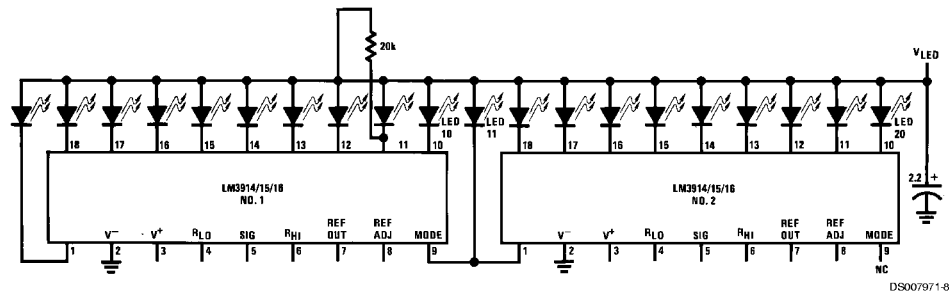

FIGURE 1. Cascading LM3914/15/16 Series in Dot Mode

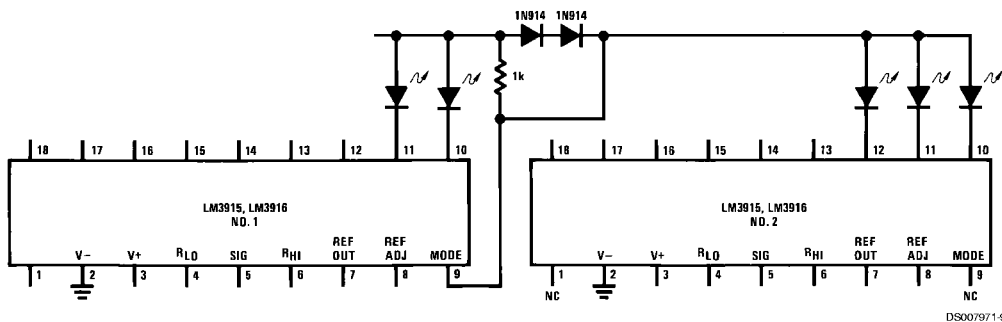

FIGURE 2. Cascading Drivers in Dot Mode with Pin 1 of Driver #2 Unused

Mode Pin Functional Description

(Continued)

OTHER DEVICE CHARACTERISTICS

The LM3915 is relatively low-powered itself, and since any number of LEDs can be powered from about 3V, it is a very efficient display driver. Typical standby supply current (all LEDs OFF) is 1.6 mA. However, any reference loading adds 4 times that current drain to the V^+ (pin 3) supply input. For example, an LM3915 with a 1 mA reference pin load (1.3k) would supply almost 10 mA to every LED while drawing only 10 mA from its V^+ pin supply. At full-scale, the IC is typically drawing less than 10% of the current supplied to the display.

The display driver does not have built-in hysteresis so that the display does not jump instantly from one LED to the next. Under rapidly changing signal conditions, this cuts down high frequency noise and often an annoying flicker. An "overlap" is built in so that at no time are all segments completely off the dot mode. Generally one LED fades in while the other fades out over a 1 mV range. The change may be much more rapid between LED #10 of one device and LED #1 of a second device cascaded.

Application Hints

The most difficult problem occurs when large LED currents are being drawn, especially in bar graph mode. These currents flowing out of the ground pin cause voltage drops in external wiring, and thus errors and oscillations. Bringing the return wires from signal sources, reference ground and bottom of the resistor string to a single point very near pin 2 is the best solution.

Long wires from V_{LED} to LED anode common can cause oscillations. The usual cure is bypassing the LED anodes with a 2.2 μ F tantalum or 10 μ F aluminum electrolytic capacitor. If the LED anode line wiring is inaccessible, often a 0.1 μ F capacitor from pin 1 to pin 2 will be sufficient.

If there is a large amount of LED overlap in the bar mode, oscillation or excessive noise is usually the problem. In cases where proper wiring and bypassing fail to stop oscillations, V^+ voltage at pin 3 is usually below suggested limits. When several LEDs are lit in dot mode, the problem is usually an AC component of the input signal which should be filtered out. Expanded scale meter applications may have one or both ends of the internal voltage divider terminated at relatively high value resistors. These high-impedance ends should be bypassed to pin 2 with 0.1 μ F.

Power dissipation, especially in bar mode should be given consideration. For example, with a 5V supply and all LEDs programmed to 20 mA the driver will dissipate over 600 mW. In this case a 7.5 Ω resistor in series with the LED supply will cut device heating in half. The negative end of the resistor should be bypassed with a 2.2 μ F solid tantalum or 10 μ F aluminum electrolytic capacitor to pin 2.

TIPS ON RECTIFIER CIRCUITS

The simplest way to display an AC signal using the LM3916 is to apply it right to pin 5 unrectified. Since the LED illuminated represents the instantaneous value of the AC waveform, one can readily discern both peak and average values of audio signals in this manner. The LM3916 will respond to positive half-cycles only but will not be damaged by signals up to ± 35 V (or up to ± 100 V if a 39k resistor is in series with the input). A smear or bar type display results even though the LM3916 is connected for dot mode. The LEDs should be run at 20 mA to 30 mA for high enough average intensity.

True average or peak detection requires rectification. If an LM3916 is set up with 10V full scale across its voltage divider, the turn-on point for the first LED is only 450 mV. A simple silicon diode rectifier won't work well at the low end due to the 600 mV diode threshold. The half-wave peak detector in Figure 3 uses a PNP emitter-follower in front of the diode. Now, the transistor's base-emitter voltage cancels out the diode offset, within about 100 mV. This approach is usually satisfactory when a single LM3916 is used for a 23 dB display.

Display circuits such as the extended range VU meter using two or more drivers for a dynamic range of 40 dB or greater require more accurate detection. In the precision half-wave rectifier of Figure 4 the effective diode offset is reduced by a factor equal to the open-loop gain of the op amp. Filter capacitor C2 charges through R3 and discharges through R2 and R3, so that appropriate selection of these values results in either a peak or an average detector. The circuit has a gain equal to $R2/R1$.

It's best to capacitively couple the input. Audio sources frequently have a small DC offset that can cause significant error at the low end of the log display. Op amps that slew quickly, such as the LF351, LF353 or LF356, are needed to faithfully respond to sudden transients. It may be necessary to trim out the op amp DC offset voltage to accurately cover a 60 dB range. Best results are obtained if the circuit is adjusted for the correct output when a low-level AC signal (10 to 20 mV) is applied, rather than adjusting for zero output with zero input.

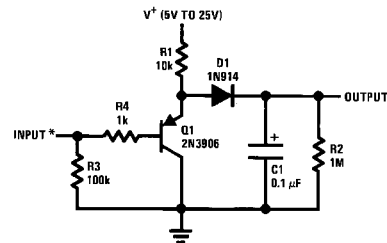

DS007971-10

*DC Couple

FIGURE 3. Half-Wave Peak Detector

Application Hints (Continued)

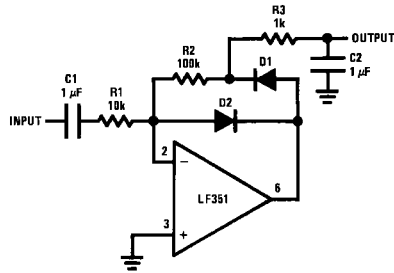

DS007971-11

D1, D2: 1N914 or 1N4148

	Average	Peak
R2	1k	100k
R3	100k	1k

$R1 = R2$ for $A_V = 1$

$R1 = R2/10$ for $A_V = 10$

$C1 = 10/R1$

FIGURE 4. Precision Half-Wave Rectifier

For precision full-wave averaging use the circuit in *Figure 5*. Using 1% resistors for R1 through R4, gain for positive and negative signal differs by only 0.5 dB worst case. Substituting 5% resistors increases this to 2 dB worst case. (A 2 dB gain difference means that the display may have a ± 1 dB error when the input is a nonsymmetrical transient). The averaging time constant is $R5 \cdot C2$. A simple modification results in the precision full-wave detector of *Figure 6*. Since the filter capacitor is not buffered, this circuit can drive only high impedance loads such as the input of an LM3916.

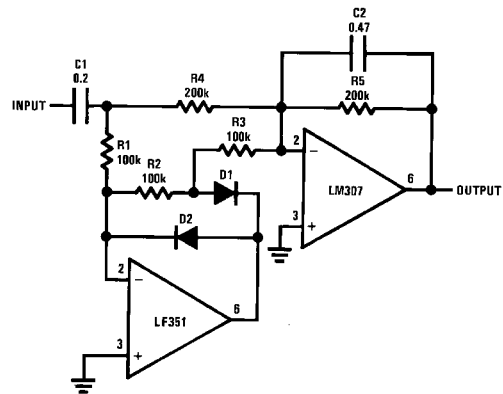

DS007971-12

D1, D2: 1N914 or 1N4148

FIGURE 5. Precision Full-Wave Average Detector

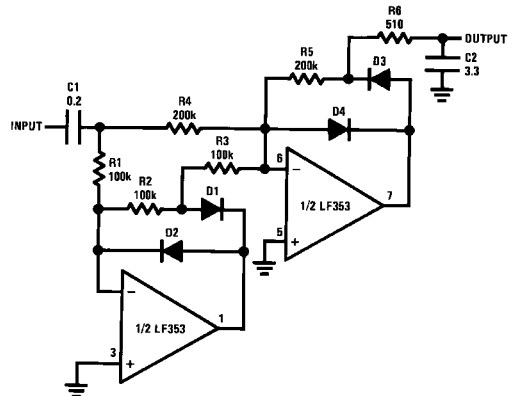

DS007971-13

D1, D2, D3, D4: 1N914 OR 1N4148

Attack and decay time to DIN PPM spec. Response down 1 dB for 10 ms tone burst. Decays 20 dB in 1.5s.

FIGURE 6. Precision Full-Wave Peak Detector

AUDIO METER STANDARDS

VU Meter

The audio level meter most frequently encountered is the VU meter. Its characteristics are defined as the ANSI specification C165. The LM3916's outputs correspond to the meter indications specified with the omission of the -2 VU indication. The VU scale divisions differ slightly from a linear scale in order to obtain whole numbers in dB.

Some of the most important specifications for an AC meter are its dynamic characteristics. These define how the meter responds to transients and how fast the reading decays. The VU meter is a relatively slow full-wave averaging type, specified to reach 99% deflection in 300 ms and overshoot by 1 to 1.5%. In engineering terms this means a slightly underdamped second order response with a resonant frequency of 2.1 Hz and a Q of 0.62. *Figure 7* depicts a simple rectifier/filter circuit that meets these criteria.

Application Hints (Continued)

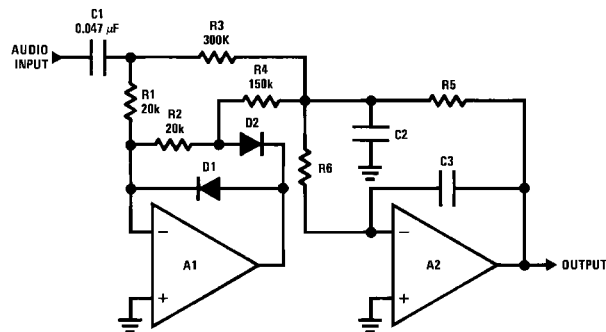

DS007971-14

Design Equations

$$\frac{1}{R5 \cdot R6 \cdot C2 \cdot C3} = \omega_0^2 = 177 \text{ sec}^{-2}$$

$$\frac{1}{C2} \left(\frac{1}{R3} + \frac{1}{R4} + \frac{1}{R5} + \frac{1}{R6} \right) = \frac{\omega_0}{Q} = 21.5 \text{ sec}^{-1}$$

$$R3 = 2R4$$

$$R1 = R2 \ll R4$$

A1, A2: 1/2 LF353

D1, D2: 1N914 OR 1N4148

*Reaches 99% level at 300 ms after applied tone burst and overshoots 1.2%.

GAIN	R5	R6	C2	C3
1	100k	43k	2.0	0.56 μF
10	1M	100k	1.0	0.056 μF

FIGURE 7. Full-Wave Average Detector to VU Meter Specifications*

Peak Program Meter

The VU meter, originally intended for signals sent via telephone lines, has shortcomings when used in high fidelity systems. Due to its slow response time, a VU meter will not accurately display transients that can saturate a magnetic tape or drive an amplifier into clipping. The fast-attack peak program meter (PPM) which does not have this problem is becoming increasingly popular.

While several European organizations have specifications for peak program meters, the German DIN specification 45406 is becoming a de facto standard. Rather than respond instantaneously to peak, however, PPM specifications require a finite "integration time" so that only peaks wide enough to be audible are displayed. DIN 45406 calls for a response of 1 dB down from steady-state for a 10 ms tone burst and 4 dB down for a 3 ms tone burst. These requirements are consistent with the other frequently encountered spec of 2 dB down for a 5 ms burst and are met by an attack time constant of 1.7 ms.

The specified return time of 1.5s to -20 dB requires a 650 ms decay time constant. The full-wave peak detector of Figure 6 satisfies both the attack and decay time criteria.

Cascading The LM3916

The LM3916 by itself covers the 23 dB range of the conventional VU meter. To display signals of 40 dB or 70 dB dynamic range, the LM3916 may be cascaded with the 3 dB/step LM3915s. Alternatively, two LM3916s may be cascaded for increased resolution over a 28 dB range. Refer to the Extended Range VU Meter and High Resolution VU Meter in the Typical Applications section for the complete circuits for both dot and bar mode displays.

To obtain a display that makes sense when an LM3915 and an LM3916 are cascaded, the -20 dB output from the LM3916 is dropped. The full-scale display for the LM3915 is set at 3 dB below the LM3916's -10 dB output and the rest of the thresholds continue the 3 dB/step spacing. A simple, low cost approach is to set the reference voltage of the two chips 16 dB apart as in Figure 5. The LM3915, with pin 8 grounded, runs at 1.25V full-scale. R1 and R2 set the LM3916's reference 16 dB higher or 7.89V. Variation in the two on-chip references and resistor tolerance may cause a ±1 dB error in the -10 dB to -13 dB transition. If this is objectionable, R2 can be trimmed.

The drawback of the aforementioned approach is that the threshold of LED #1 on the LM3915 is only 56 mV. Since comparator offset voltage may be as high as 10 mV, large errors can occur at the first few thresholds. A better approach, as shown in Figure 9, is to keep the reference the same for

Application Hints (Continued)

both drivers (10V in the example) and *amplify* the input signal by 16 dB ahead of the LM3915. Alternatively, instead of

amplifying, input signals of sufficient amplitude can be fed directly to the LM3916 and *attenuated* by 16 dB to drive the LM3915.

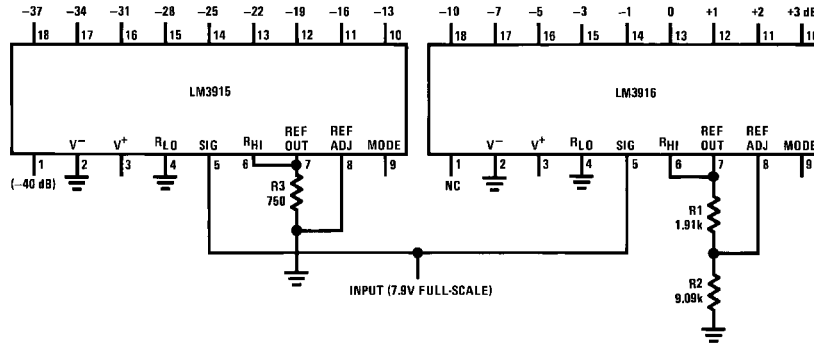

DS007971-15

$$V_{REF2} \cong 7.89V$$

$$V_{REF1} = 1.25V$$

$$\frac{7.89V}{1.25} = 6.31 = -16 \text{ dB}$$

FIGURE 8. Low Cost Circuit for 40 dB Display

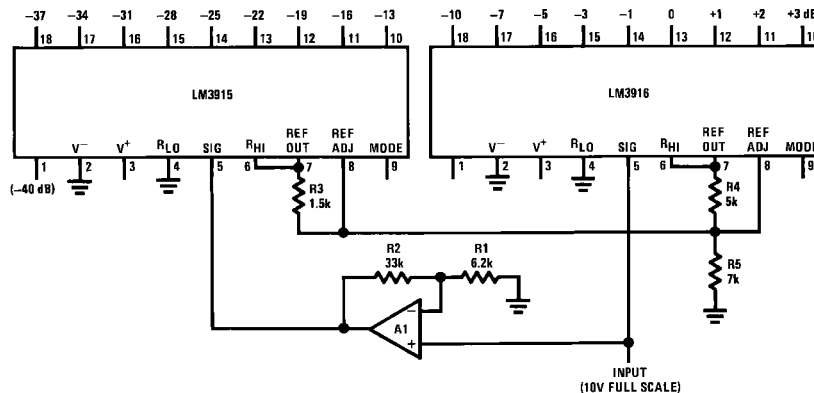

DS007971-16

$$\frac{R1 + R2}{R1} = 6.31$$

$$= 16 \text{ dB}$$

FIGURE 9. Improved Circuit for 40 dB Display

To extend this approach to get a 70 dB display, another 30 dB of amplification must be placed in the signal path ahead of the lowest LM3915. Extreme care is required as the lowest LM3915 displays input signals down to 2 mV! Several offset nulls may be required. High currents should not share the same path as the low level signal. Also power line wiring should be kept away from signal lines.

TIPS ON REFERENCE VOLTAGE AND LED CURRENT PROGRAMMING

Single Driver

The equations in *Figure 10* illustrate how to choose resistor values to set reference voltage for the simple case where no LED intensity adjustment is required. A LED current of 10 mA to 20 mA generally produces adequate illumination. Having 10V full-scale across the internal voltage divider gives best accuracy by keeping signal level high relative to the offset voltage of the internal comparators. However, this causes 1

Application Hints (Continued)

mA to flow from pin 7 into the divider which means that the LED current will be at least 10 mA. R1 will typically be between 1 kΩ and 5 kΩ. To trim the reference voltage, vary R2.

The current in *Figure 11* shows how to add a LED intensity control which can vary LED current from 5 mA to 28 mA. Choosing $V_{REF} = 5V$ lowers the current drawn by the ladder, increasing the intensity adjustment range. The reference adjustment has some effect on LED intensity but the reverse is not true.

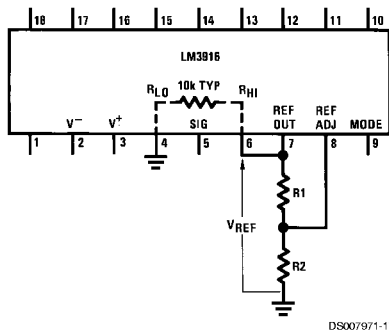

DS007971-17

Adjust R2 to vary V_{REF}

$$\text{Pick } R1 = \frac{12.5V}{I_{LED} - V_{REF}/1k\Omega}$$

$$\text{Pick } R2 = \frac{(V_{REF} - 1.25V)}{1.25V/R1 + 0.08 \text{ mA}}$$

FIGURE 10. Design Equations for Fixed LED Intensity

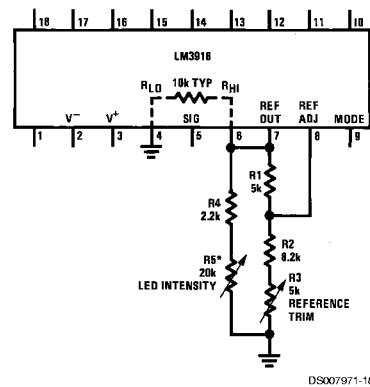

DS007971-18

$$5 \text{ mA} \leq I_{LED} \leq 28 \text{ mA} @ V_{REF} = 5V$$

FIGURE 11. Varying LED Intensity

Multiple Drivers

Figure 12 shows how to obtain a common reference trim and intensity control for two drivers. The two ICs may be connected in cascade or may be handling separate channels for stereo. This technique can be extended for larger numbers of drivers by varying the values of R1, R2 and R3. Because the LM3915 has a greater ladder resistance, R5 was picked less than R7 in such a way as to provide equal reference load currents. The ICs' internal references track within 100 mV so that worst case error from chip to chip is only 0.2 dB for $V_{REF} = 5V$.

The scheme in *Figure 13* is useful when the reference and LED intensity must be adjusted independently over a wide range. The R_{HI} voltage can be adjusted from 1.2V to 10V with no effect on LED current. Since the internal divider here does not load down the reference, minimum LED current is much lower. At the minimum recommended reference load of 80 μA , LED current is about 0.8 mA. The resistor values shown give a LED current range from 1.5 mA to 25 mA.

At the low end of the intensity adjustment, the voltage drop across the 510 Ω current-sharing resistors is so small that chip to chip variation in reference voltage may yield a visible variation in LED intensity. The optional approach shown of connecting the bottom end of the intensity control pot to a negative supply overcomes this problem by allowing a larger voltage drop across the (larger) current-sharing resistors.

Application Hints (Continued)

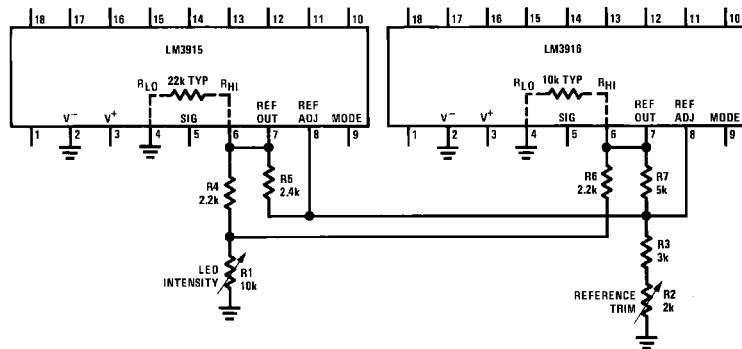

DS007971-19

$5 \text{ mA} \leq I_{LED} \leq 28 \text{ mA}$
 $V_{REF} = 5V$

FIGURE 12. Independent Adjustment of Reference Voltage and LED Intensity for Multiple Drivers

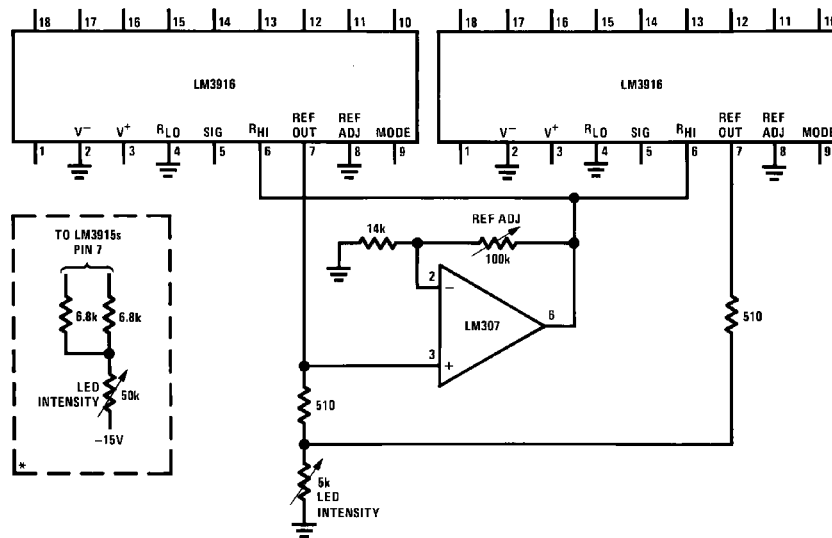

DS007971-20

$1.25V \leq V_{REF} \leq 10V$
 $1.5 \text{ mA} \leq I_{LED} \leq 25 \text{ mA}$
 Optional circuit for improved intensity matching at low currents. See text.

FIGURE 13. Wide-Range Adjustment of Reference Voltage and LED intensity for Multiple Drivers

Other Applications

For increased resolution, it's possible to obtain a display with a smooth transition between LEDs. This is accomplished by superimposing an AC waveform on top of the input level as

shown in *Figure 14*. The signal can be a triangle, sawtooth or sine wave from 60 Hz to 1 kHz. The display can be run in either dot or bar mode.

Other Applications (Continued)

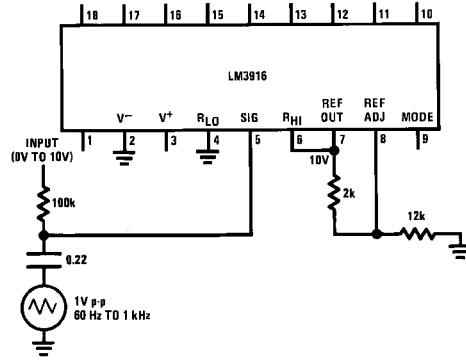

DS007971-21

FIGURE 14. 0V to 10V VU Meter with Smooth Transitions

Typical Applications

Extended Range VU Meter (Dot Mode)

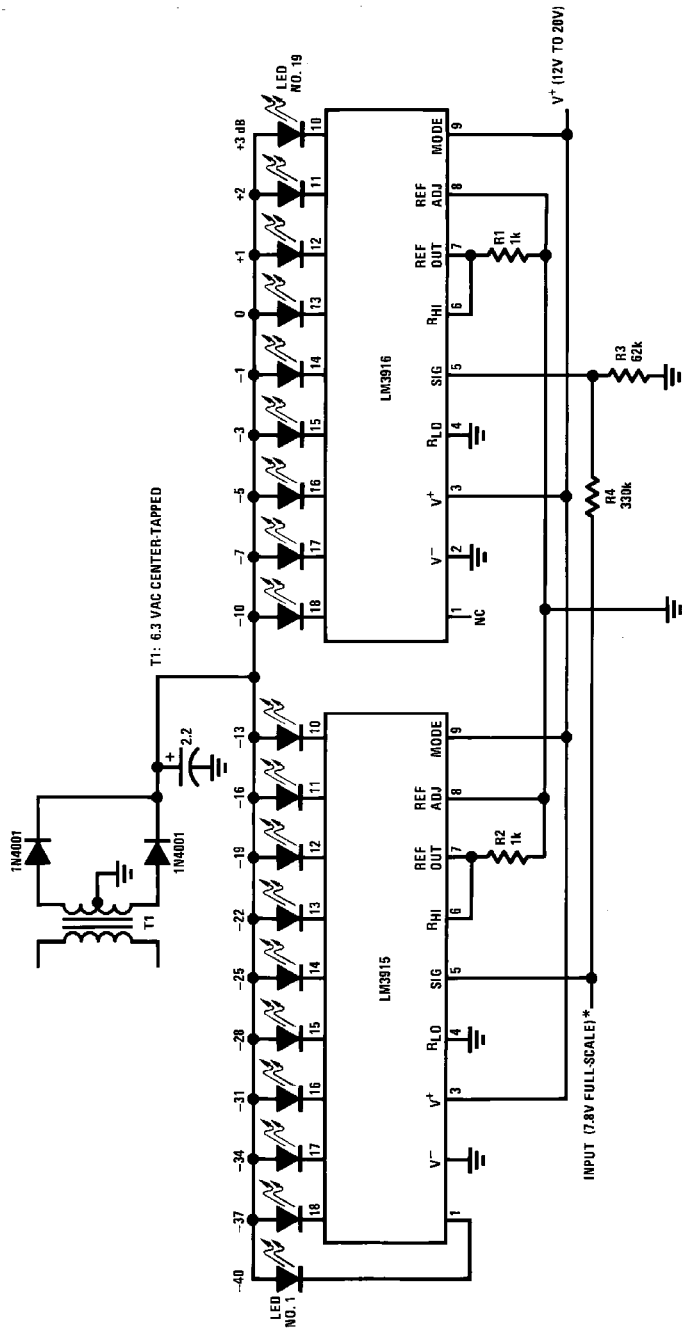

This application shows that the LED supply requires minimal filtering.
 *See Application Hints for optional Peak or Average Detector.
 †Adjust R3 for 3 dB difference between LED #11 and LED #12

$$\frac{R3}{R3 + R4} = 0.158 = -16 \text{ dB}$$

DS9007971-22

Typical Applications (Continued)

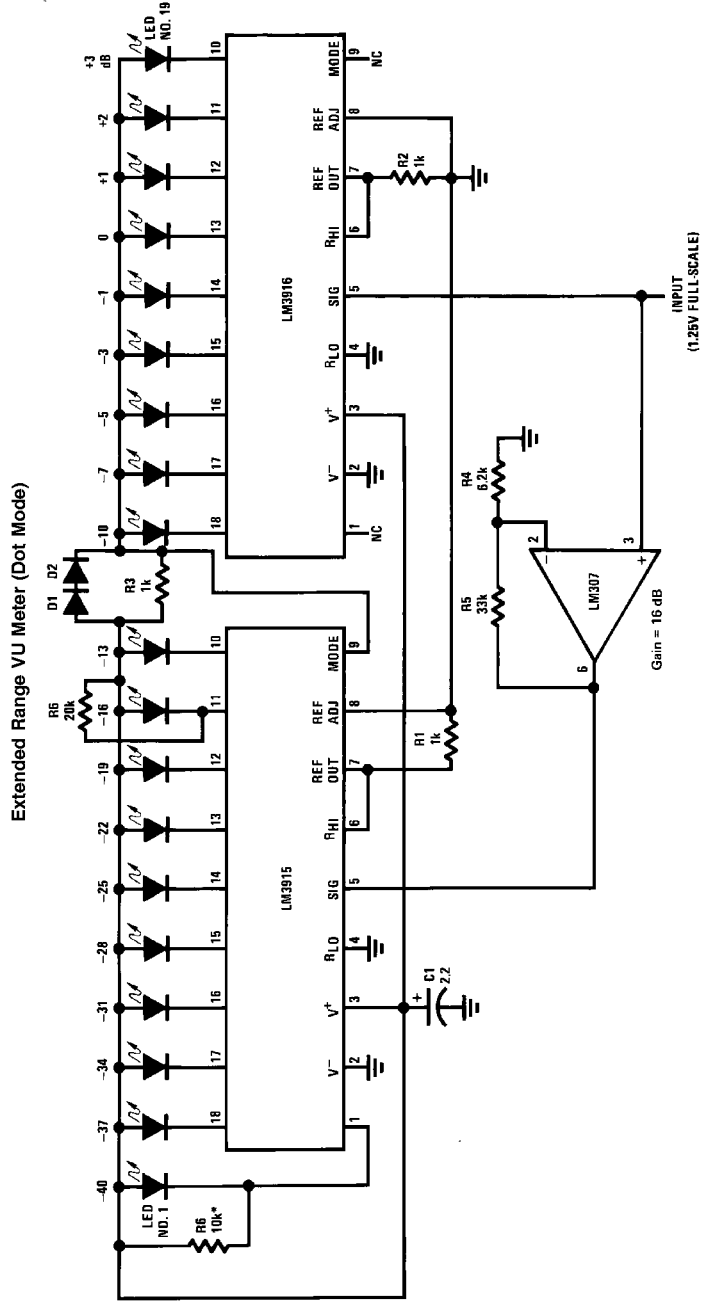

D1, D2: 1N914 or 1N4148
 *OPTIONAL SHUNTS 100 µA auxiliary sink current away from LED #1.
 †See Application Hints for optional peak or average detector.

Typical Applications (Continued)

Driving Vacuum Fluorescent Display

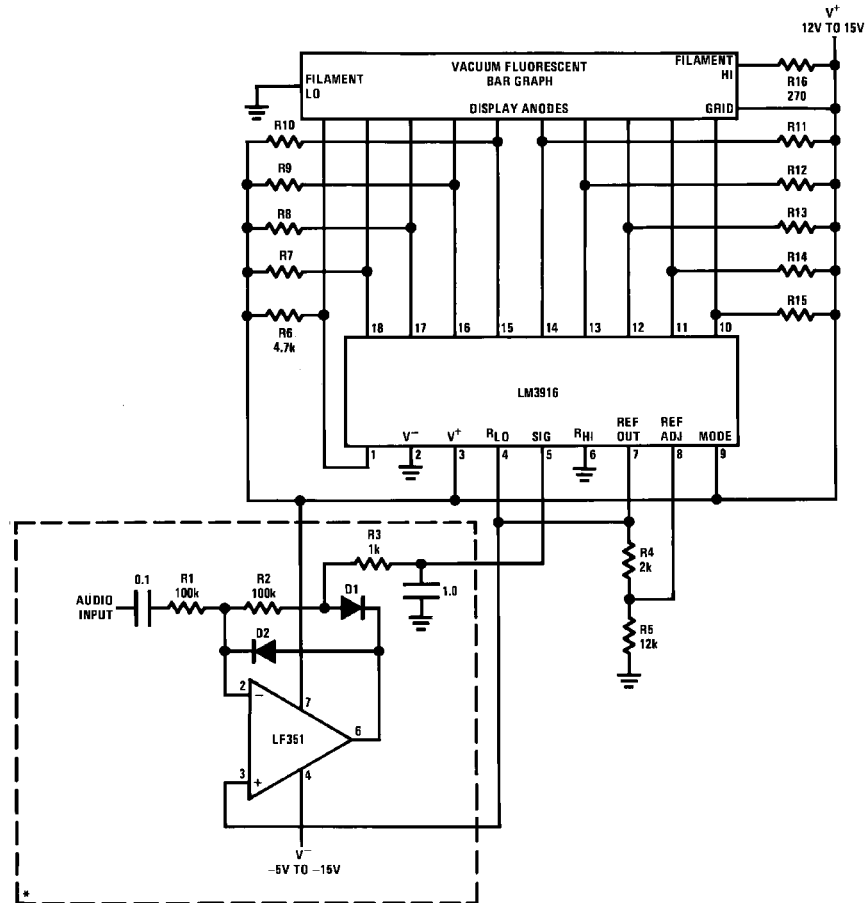

R7 thru R15: $10k \pm 10\%$
 D1, D2: 1N914 or 1N4148
 *Half-wave peak detector.
 See Application Hints.

DS007971-24

Typical Applications (Continued)

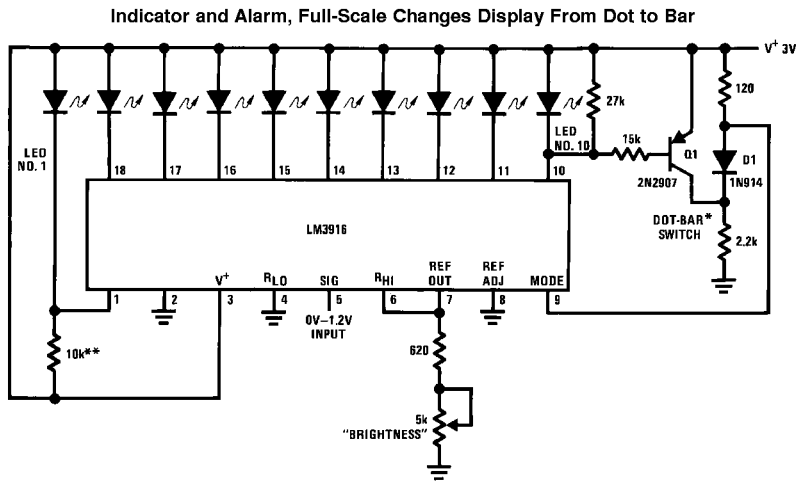

DS007971-25

- *The input to the Dot-Bar switch may be taken from cathodes of other LEDs. Display will change to bar as soon as the LED so selected begins to light.
- **Optional. Shunts 100 μ A auxiliary sink current away from LED #1.

Typical Applications (Continued)

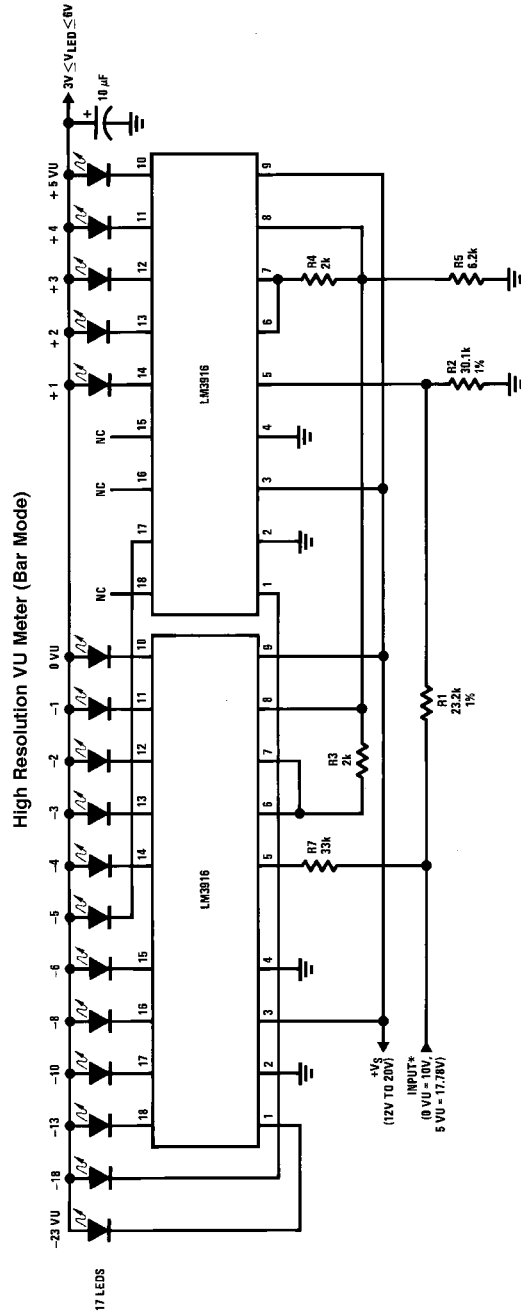

*See Application Hints for optional peak or average detector.

$$\frac{R2}{R1 + R2} \cong 0.562 = -5 \text{ dB}$$

or $R1 \cong 0.788 \cdot R2$

DS90J971-26

Typical Applications (Continued)

High Resolution VU Meter (Dot Mode)

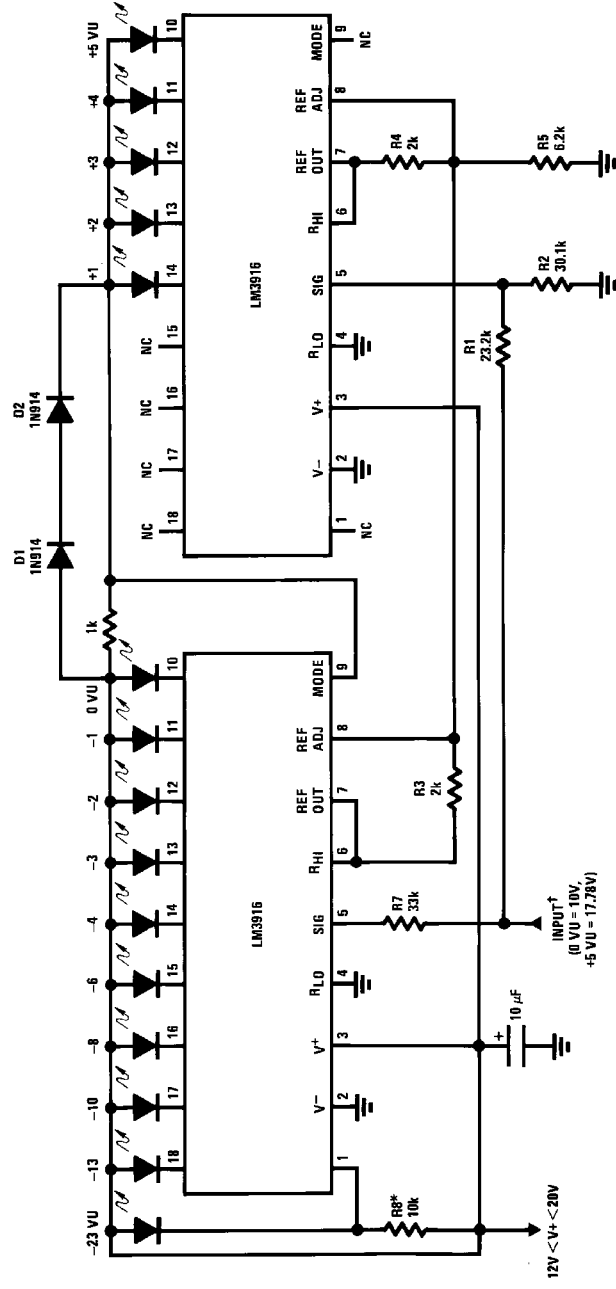

DS007971-27

*Optional shunts 100 µA auxiliary sink current away from LED #1.
 †See Application Hints for optional peak or average detector.

$$\frac{R2}{R1 + R2} \cong 0.562 = -5 \text{ dB}$$

or $R1 \cong 0.788 \cdot R2$

Typical Applications (Continued)

Displaying Additional Levels

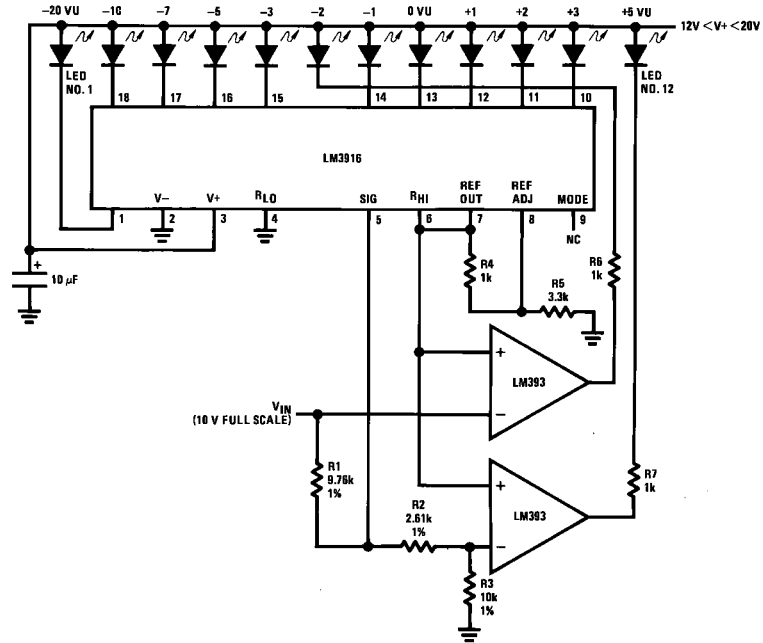

DS007971-28

$$\frac{R3}{R2 + R3} \cong 0.794 = -2 \text{ dB}$$

$$\frac{R2 + R3}{R1 + R2 + R3} \cong 0.562 = -5 \text{ dB}$$

$$\text{or } R2 = 0.259 \cdot R3$$

$$\text{and } R1 = 0.979 \cdot R3$$

Typical Applications (Continued)

Operating with a High Voltage Supply (Dot Mode Only)

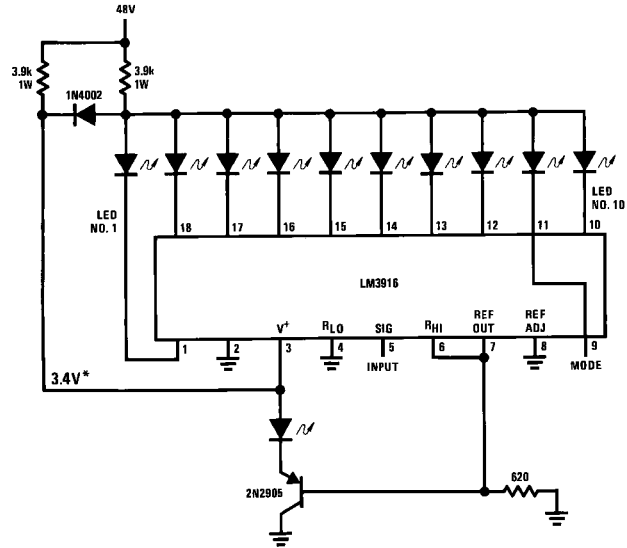

DS007971-29

The LED currents are approximately 10 mA, and LM3916 outputs operate in saturation for minimum dissipation.
 *This point is partially regulated and decreases in voltage with temperature. Voltage requirements of the LM3916 also decrease with temperature.

Low Current Bar Mode Display

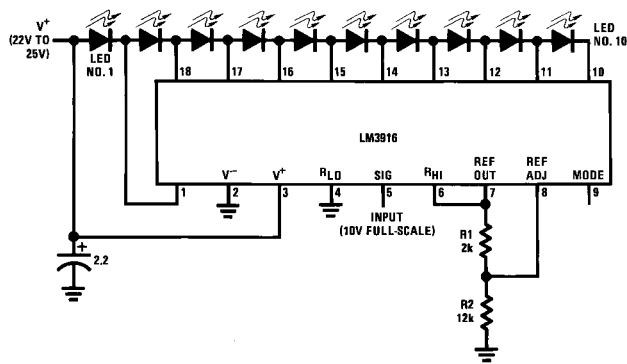

DS007971-30

Supply current drain is only 20 mA with ten LEDs illuminated @ 16 mA.

Typical Applications (Continued)

Driving Liquid Crystal Display

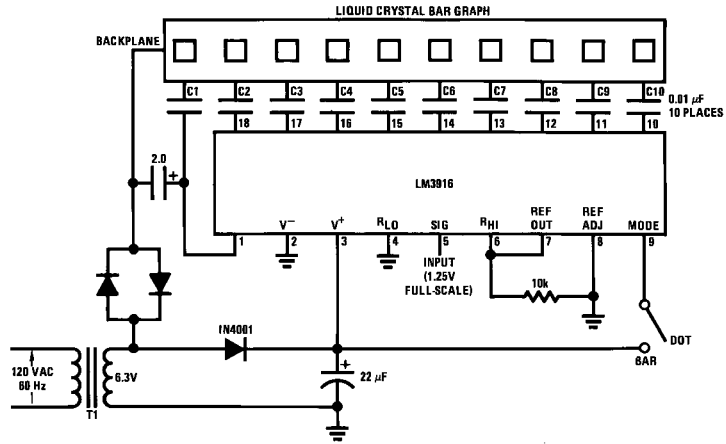

Bar Display with Alarm Flasher

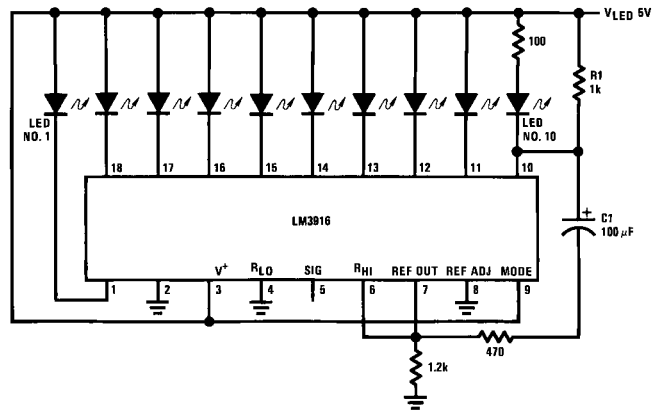

Full-scale causes the full bar display to flash. If the junction of R1 and C1 is connected to a different LED cathode, the display will flash when that LED lights, and at any higher input signal.

Connection Diagram

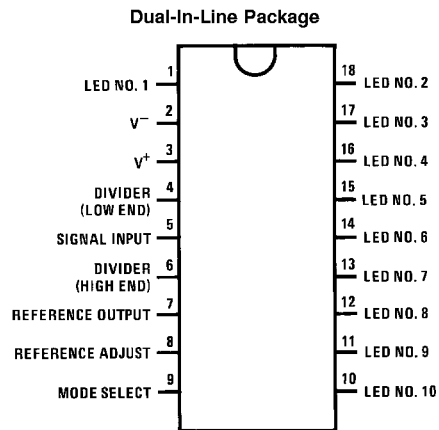

DS907971-33

Top View
Order Number LM3916N
See NS Package Number N18A

Definition of Terms

Absolute Accuracy: The difference between the observed threshold voltage and the ideal threshold voltage for each comparator. Specified and tested with 10V across the internal voltage divider so that resistor ratio matching error predominates over comparator offset voltage.

Adjust Pin Current: Current flowing out of the reference amplifier pin when the reference amplifier is in the linear region.

Comparator Gain: The ratio of the change in output current (I_{LED}) to the change in input voltage (V_{IN}) required to produce it for a comparator in the linear region.

Dropout Voltage: The voltage measured at the current source outputs required to make the output current fall by 10%.

Input Bias Current: Current flowing out of the signal input when the input buffer is in the linear region.

LED Current Regulation: The change in output current over the specified range of LED supply voltage (V_{LED}) as

measured at the current source outputs. As the forward voltage of an LED does not change significantly with a small change in forward current, this is equivalent to changing the voltage at the LED anodes by the same amount.

Line Regulation: The average change in reference output voltage (V_{REF}) over the specified range of supply voltage (V^+).

Load Regulation: The change in reference output voltage over the specified range of load current ($I_{L(REF)}$).

Offset Voltage: The differential input voltage which must be applied to each comparator to bias the output in the linear region. Most significant error when the voltage across the internal voltage divider is small. Specified and tested with pin 6 voltage (V_{RHI}) equal to pin 4 voltage (V_{RLO}).

Relative Accuracy: The difference between any two adjacent threshold points. Specified and tested with 10V across the internal voltage divider so that resistor ratio matching error predominates over comparator offset voltage.

Physical Dimensions inches (millimeters) unless otherwise noted

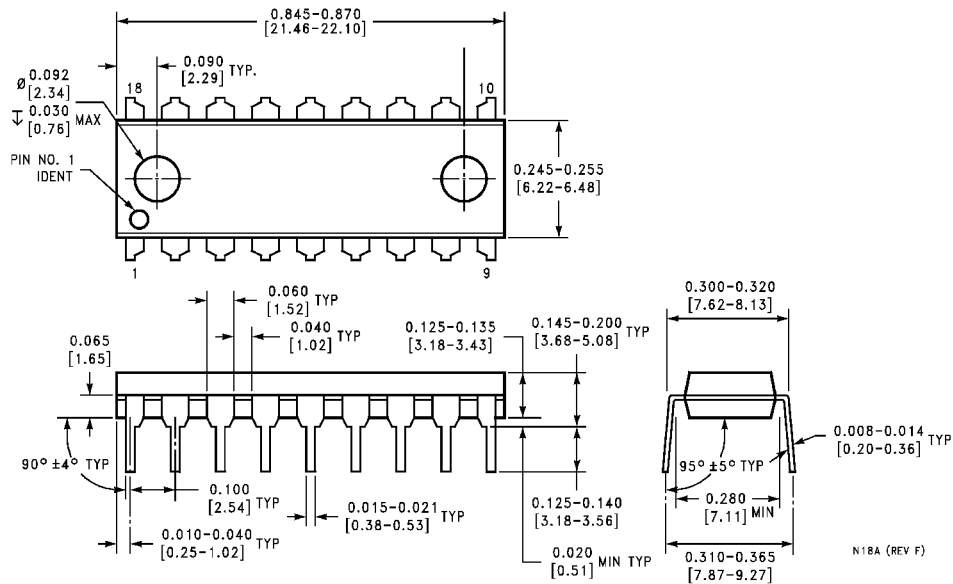

Molded Dual-In-Line Package (N)
Order Number LM3916N
NS Package Number N18A

LIFE SUPPORT POLICY

NATIONAL'S PRODUCTS ARE NOT AUTHORIZED FOR USE AS CRITICAL COMPONENTS IN LIFE SUPPORT DEVICES OR SYSTEMS WITHOUT THE EXPRESS WRITTEN APPROVAL OF THE PRESIDENT AND GENERAL COUNSEL OF NATIONAL SEMICONDUCTOR CORPORATION. As used herein:

1. Life support devices or systems are devices or systems which, (a) are intended for surgical implant into the body, or (b) support or sustain life, and whose failure to perform when properly used in accordance with instructions for use provided in the labeling, can be reasonably expected to result in a significant injury to the user.
2. A critical component is any component of a life support device or system whose failure to perform can be reasonably expected to cause the failure of the life support device or system, or to affect its safety or effectiveness.



National Semiconductor Corporation
 Americas
 Tel: 1-800-272-9959
 Fax: 1-800-737-7018
 Email: support@nsc.com

www.national.com

National Semiconductor Europe
 Fax: +49 (0) 1 80-530 85 86
 Email: europe.support@nsc.com
 Deutsch Tel: +49 (0) 1 80-530 85 85
 English Tel: +49 (0) 1 80-532 78 32
 Français Tel: +49 (0) 1 80-532 93 58
 Italiano Tel: +49 (0) 1 80-534 16 80

National Semiconductor Asia Pacific Customer Response Group
 Tel: 65-2544466
 Fax: 65-2504466
 Email: sea.support@nsc.com

National Semiconductor Japan Ltd.
 Tel: 81-3-5639-7560
 Fax: 81-3-5639-7507