

LM710

Voltage Comparator

The LM710 series are high-speed voltage comparators intended for use as an accurate, low-level digital level sensor or as a replacement for operational amplifiers in comparator applications where speed is of prime importance. The circuit has a differential input and a single-ended output, with saturated output levels compatible with practically all types of integrated logic.

The device is built on a single silicon chip which insures low offset and thermal drift. The use of a minimum number of stages along with minority-carrier lifetime control (gold doping) makes the circuit much faster than operational amplifiers in saturating comparator applications. In fact, the low stray and wiring capacitances that can be realized with monolithic construction make the device difficult to duplicate with discrete components operating at equivalent power levels.

Rochester Electronics Manufactured Components

Rochester branded components are manufactured using either die/wafers purchased from the original suppliers or Rochester wafers recreated from the original IP. All recreations are done with the approval of the OCM.

Parts are tested using original factory test programs or Rochester developed test solutions to guarantee product meets or exceeds the OCM data sheet.

Quality Overview

- ISO-9001
- AS9120 certification
- Qualified Manufacturers List (QML) MIL-PRF-38535
 - Class Q Military
 - Class V Space Level
- Qualified Suppliers List of Distributors (QSLD)
 - Rochester is a critical supplier to DLA and meets all industry and DLA standards.

Rochester Electronics, LLC is committed to supplying products that satisfy customer expectations for quality and are equal to those originally supplied by industry manufacturers.

The original manufacturer's datasheet accompanying this document reflects the performance and specifications of the Rochester manufactured version of this device. Rochester Electronics guarantees the performance of its semiconductor products to the original OEM specifications. 'Typical' values are for reference purposes only. Certain minimum or maximum ratings may be based on product characterization, design, simulation, or sample testing.

LM710 Voltage Comparator

General Description

The LM710 series are high-speed voltage comparators intended for use as an accurate, low-level digital level sensor or as a replacement for operational amplifiers in comparator applications where speed is of prime importance. The circuit has a differential input and a single-ended output, with saturated output levels compatible with practically all types of integrated logic.

The device is built on a single silicon chip which insures low offset and thermal drift. The use of a minimum number of stages along with minority-carrier lifetime control (gold doping) makes the circuit much faster than operational amplifiers in saturating comparator applications. In fact, the low

stray and wiring capacitances that can be realized with monolithic construction make the device difficult to duplicate with discrete components operating at equivalent power levels.

The LM710 series are useful as pulse height discriminators, voltage comparators in high-speed A/D converters or go, no-go detectors in automatic test equipment. They also have applications in digital systems as an adjustable-threshold line receiver or an interface between logic types. In addition, the low cost of the units suggests them for applications replacing relatively simple discrete component circuitry.

Schematic and Connection Diagrams

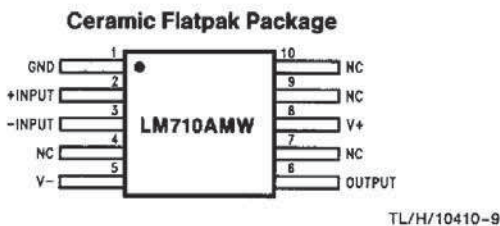
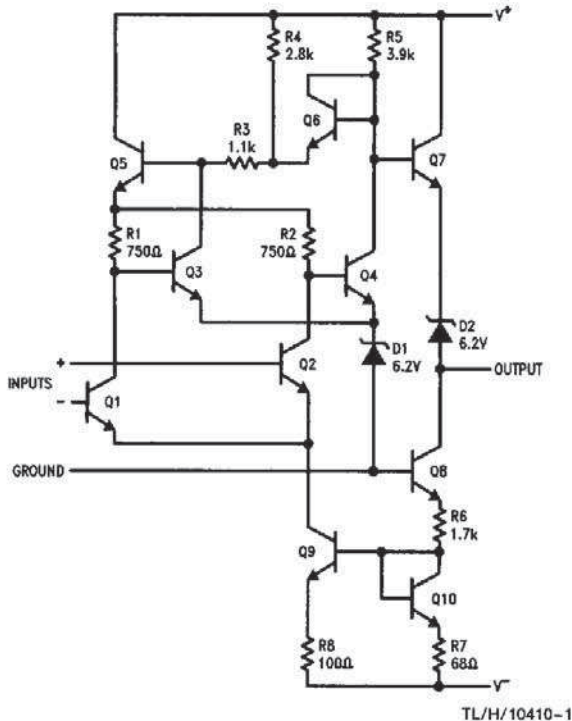

Order Number LM710AMW/883*
See NS Package Number W10A

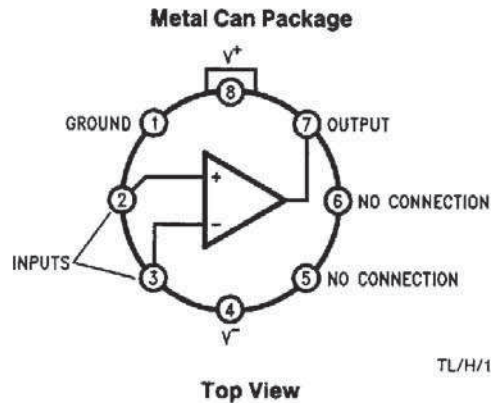

Note: Pin 4 is connected to case.

**Order Number LM710AMH/883*, LM710H,
LM710H/883 or LM710CH**
See NS Package Number H08C

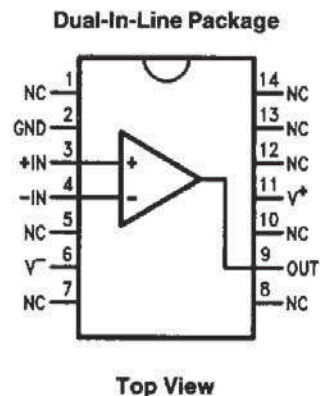

**Order Number
LM710AMJ/883* or LM710CN**
See NS Package Number N14A or J14A

*Also available per JM38510/10301

Absolute Maximum Ratings

If Military/Aerospace specified devices are required, please contact the National Semiconductor Sales Office/Distributors for availability and specifications.

Positive Supply Voltage	+14V
Negative Supply Voltage	-7V
Peak Output Current	10 mA
Output Short Circuit Duration	10 seconds
Differential Input Voltage	±5V
Input Voltage	±7V

Power Dissipation	
TO-99 (Note 1)	700 mW
Plastic Dual-In-Line Package (Note 2)	950 mW
Operating Temperature Range	
LM710	-55°C to +125°C
LM710C	0°C to +70°C
Storage Temperature Range	-65°C to +150°C
Lead Temperature (Soldering, 10 sec.)	260°C

Electrical Characteristics (Note 3)

Parameter	Conditions	LM710			LM710C			Units
		Min	Typ	Max	Min	Typ	Max	
Input Offset Voltage	$R_S \leq 200\Omega$, $V_{CM} = 0V$, $T_A = 25^\circ C$		0.6	2.0		1.6	5.0	mV
Input Offset Current	$V_{OUT} = 1.4V$, $T_A = 25^\circ C$		0.75	3.0		1.8	5.0	μA
Input Bias Current	$T_A = 25^\circ C$		13	20		16	25	μA
Voltage Gain	$T_A = 25^\circ C$	1250	1700		1000	1500		
Output Resistance	$T_A = 25^\circ C$		200			200		Ω
Output Sink Current	$V_{OUT} = 0$, $T_A = 25^\circ C$ $\Delta V_{IN} \geq 5 mV$ $\Delta V_{IN} \geq 10 mV$	2.0	2.5		1.6	2.5		μA mA
Response Time	$T_A = 25^\circ C$ (Note 4)		40			40		ns
Input Offset Voltage	$R_S \leq 200\Omega$, $V_{CM} = 0V$			3.0			6.5	mV
Average Temperature Coefficient of Input Offset Voltage	$T_{MIN} \leq T_A \leq T_{MAX}$ $R_S \leq 50\Omega$		3.0	10		5.0	20	$\mu V/^\circ C$
Input Offset Current	$T_A = T_{A MAX}$ $T_A = T_{A MIN}$		0.25 1.8	3.0 7.0			7.5 7.5	μA μA
Average Temperature Coefficient of Input Offset Current	$25^\circ C \leq T_A \leq T_{MAX}$ $T_{MIN} \leq T_A \leq 25^\circ C$		5.0 15	25 75		15 24	50 100	nA/°C nA/°C
Input Bias Current	$T_A = T_{MIN}$		27	45		25	40	μA
Input Voltage Range	$V^- = -7V$	±5.0			±5.0			V
Common-Mode Rejection Ratio	$R_S \leq 200\Omega$	80	100		70	98		dB
Differential Input Voltage Range		±5.0			±5.0			V
Voltage Gain		1000			800			V/V
Positive Output Level	$-5 mA \leq I_{OUT} \leq 0$ $V_{IN} \geq 5 mV$ $V_{IN} \geq 10 mV$	2.5	3.2	4.0	2.5	3.2	4.0	V V
Negative Output Level	$V_{IN} \geq 5 mV$ $V_{IN} \geq 10 mV$	-1.0	-0.5	0	-1.0	-0.5	0	V V
Output Sink Current	$V_{IN} \geq 5 mV$, $V_{OUT} = 0$ $T_A = 125^\circ C$ $T_A = -55^\circ C$	0.5 1.0	1.7 2.3					μA mA
	$V_{IN} \geq 10 mV$, $V_{OUT} = 0$ $0^\circ C \leq T_A \leq +70^\circ C$				0.5			mA

Electrical Characteristics (Note 3) (Continued)

Parameter	Conditions	LM710			LM710C			Units
		Min	Typ	Max	Min	Typ	Max	
Positive Supply Current	$V_{IN} \geq 5\text{ mV}$ $V_{IN} \geq 10\text{ mV}$		5.2	9.0		5.2	9.0	mA mA
Negative Supply Current	$V_{IN} \geq 5\text{ mV}$ $V_{IN} \geq 10\text{ mV}$		4.6	7.0		4.6	7.0	mA mA
Power Consumption	$I_{OUT} = 0$ $V_{IN} \geq 5\text{ mV}$ $V_{IN} \geq 10\text{ mV}$		90	150			150	mW mW

Note 1: Rating applies for ambient temperatures of 25°C; derate linearly at 5.6 mW/°C for ambient temperatures above 25°C.

Note 2: Derate linearly at 9.5 mW/°C for ambient temperatures above 25°C.

Note 3: These specifications apply for $V^+ = 12\text{V}$, $V^- = -6\text{V}$, $-55^\circ\text{C} \leq T_A \leq +125^\circ\text{C}$ for LM710 and $0^\circ\text{C} \leq T_A \leq +70^\circ\text{C}$ for LM710C unless otherwise specified: The input offset voltage and input offset current (see definitions) are specified for a logic threshold voltage of 1.8V at -55°C , 1.4V at 25°C , and 1V at 125°C for LM710 and 1.5V at 0°C , 1.4V at 25°C , and 1.2V at 70°C for LM710C.

Note 4: The response time specified (see definitions) is for a 100 mV input step with 5 mV overdrive (LM710) or a 10 mV overdrive (LM710C).

Typical Applications

Schmitt Trigger

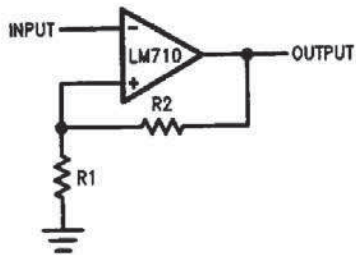

TL/H/10410-4

Line Receive with Increased Output Sink Current

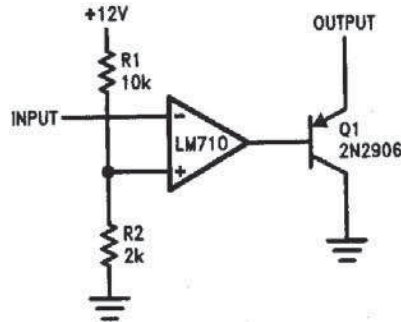

TL/H/10410-5

Pulse Width Modulator

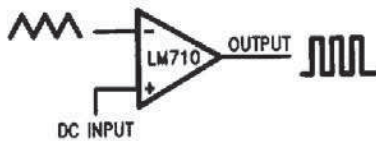

TL/H/10410-6

Level Detector with Lamp Driver

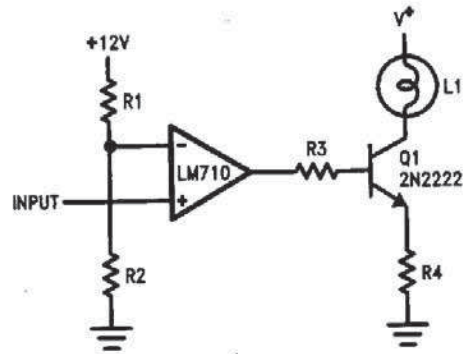

TL/H/10410-7

Typical Performance Characteristics

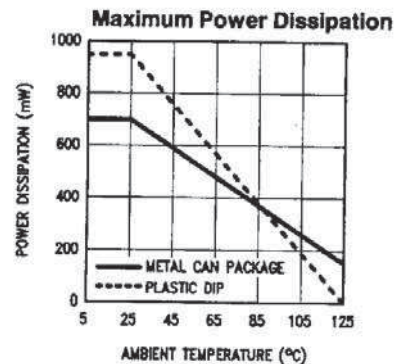
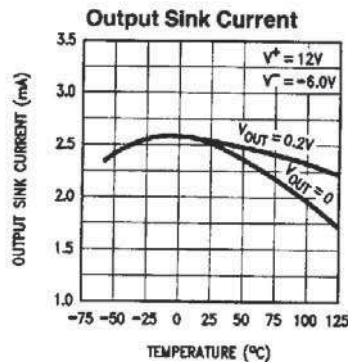
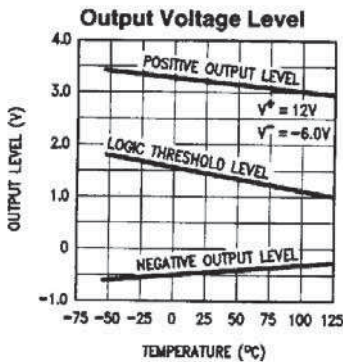
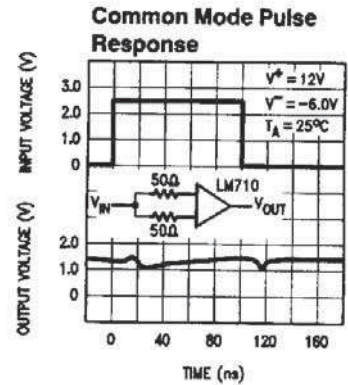
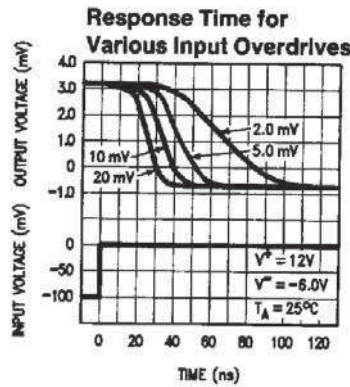
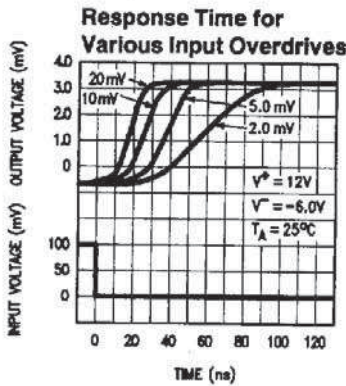
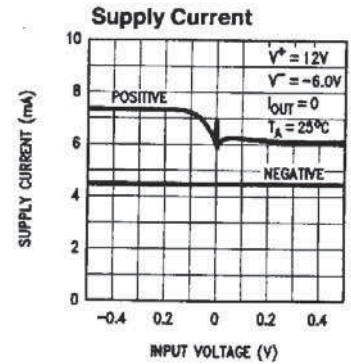
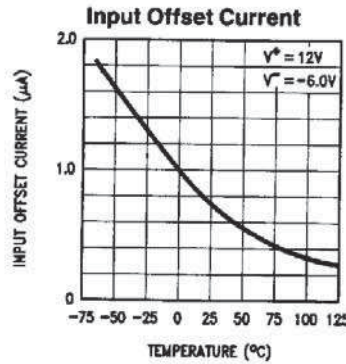
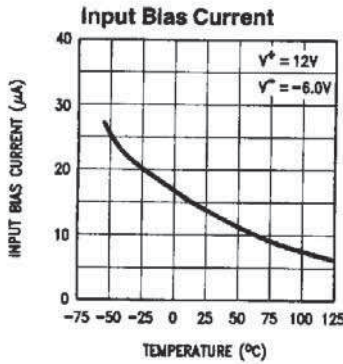
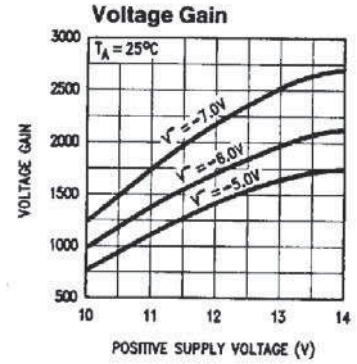
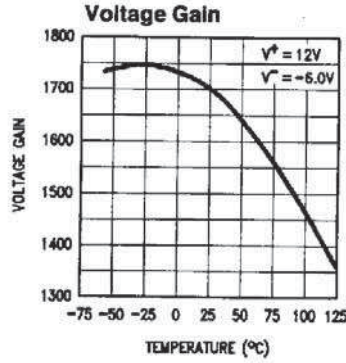
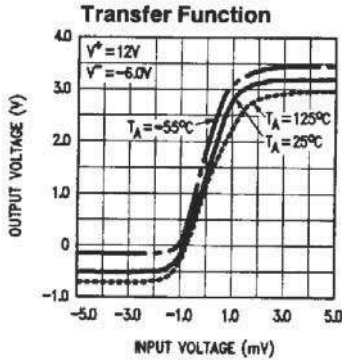

TL/H/10410-8