

MM54C90, MM74C90, MM54C93, MM74C93

Decade Counter; Binary Counter

The MM54C90/MM74C90 decade counter and the MM54C93/MM74C93 binary counter and complementary MOS (CMOS) integrated circuits constructed with N- and P-channel enhancement mode transistors. The 4-bit decade counter can reset to zero or preset to nine by applying appropriate logic level on the R01, R02, R91, and R92 inputs. Also, a separate flip-flop on the A-bit enables the user to operate it as a divide-by-2, 5, or 10 frequency counter. The 4-bit binary counter can be reset to zero by applying high logic level on inputs R01 and R02, and a separate flip-flop on the A-bit enables the user to operate it as a divide-by-2, -8, or -16 divider. Counting occurs on the negative going edge of the input pulse.

Rochester Electronics Manufactured Components

Rochester branded components are manufactured using either die/wafers purchased from the original suppliers or Rochester wafers recreated from the original IP. All recreations are done with the approval of the OCM.

Parts are tested using original factory test programs or Rochester developed test solutions to guarantee product meets or exceeds the OCM data sheet.

Quality Overview

- ISO-9001
- AS9120 certification
- Qualified Manufacturers List (QML) MIL-PRF-38535
 - Class Q Military
 - Class V Space Level
- Qualified Suppliers List of Distributors (QSLD)
 - Rochester is a critical supplier to DLA and meets all industry and DLA standards.

Rochester Electronics, LLC is committed to supplying products that satisfy customer expectations for quality and are equal to those originally supplied by industry manufacturers.

The original manufacturer's datasheet accompanying this document reflects the performance and specifications of the Rochester manufactured version of this device. Rochester Electronics guarantees the performance of its semiconductor products to the original OEM specifications. 'Typical' values are for reference purposes only. Certain minimum or maximum ratings may be based on product characterization, design, simulation, or sample testing.



MM54C90/MM74C90 4-Bit Decade Counter MM54C93/MM74C93 4-Bit Binary Counter

General Description

The MM54C90/MM74C90 decade counter and the MM54C93/MM74C93 binary counter and complementary MOS (CMOS) integrated circuits constructed with N- and P-channel enhancement mode transistors. The 4-bit decade counter can reset to zero or preset to nine by applying appropriate logic level on the R_{01} , R_{02} , R_{91} and R_{92} inputs. Also, a separate flip-flop on the A-bit enables the user to operate it as a divide-by-2, 5 or 10 frequency counter. The 4-bit binary counter can be reset to zero by applying high logic level on inputs R_{01} and R_{02} , and a separate flip-flop on the A-bit enables the user to operate it as a divide-by-2, -8, or -16 divider. Counting occurs on the negative going edge of the input pulse.

All inputs are protected against static discharge damage.

Features

- Wide supply voltage range 3V to 15V
- Guaranteed noise margin 1V
- High noise immunity 0.45 V_{CC} (typ.)
- Low power Fan out of 2 driving 74L TTL compatibility
- The MM54C93/MM74C93 follows the MM54L93/MM74L93 Pinout

Connection and Logic Diagrams

MM54C90/MM74C90
Dual-In-Line Package

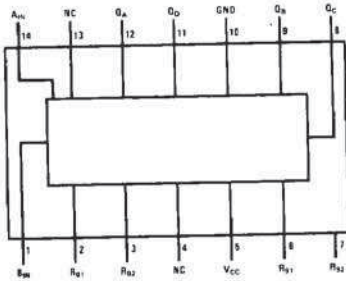

TL/F/5889-2

Top View

MM54C93/MM74C93
Dual-In-Line Package

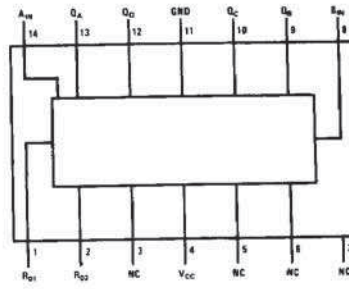

TL/F/5889-4

Top View

Order Number MM54C90* or MM74C93*

*Please look into Section 8, Appendix D for availability of various package types.

MM54C90/MM74C90

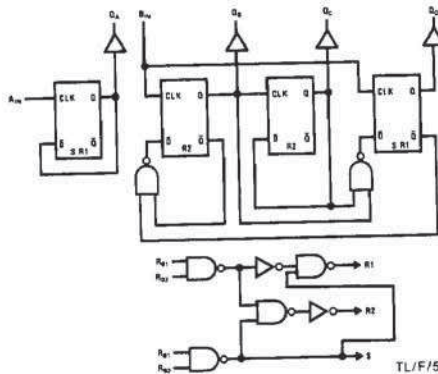

TL/F/5889-1

MM54C93/MM74C93

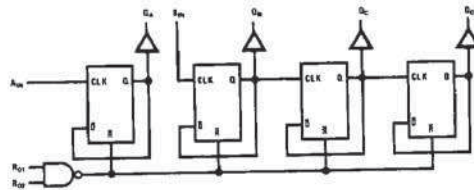

TL/F/5889-3

Absolute Maximum Ratings

If Military/Aerospace specified devices are required, contact the National Semiconductor Sales Office/Distributors for availability and specifications.

Voltage at Any Pin (Note 1)	-0.3V to $V_{CC} + 0.3V$
Operating Temperature Range (T_A)	
MM54C90, MM54C93	-55°C to +125°C
MM74C90, MM74C93	-40°C to +85°C

Power Dissipation (P_D)	
Dual-In-Line	700 mW
Small Outline	500 mW
Operating V_{CC} Range	3V to 15V
Absolute Maximum V_{CC}	18V
Storage Temperature Range (T_S)	-65°C to +150°C
Lead Temperature (T_L)	
(Soldering, 10 seconds)	260°C

DC Electrical Characteristics Min/Max limits apply across temperature range unless otherwise noted

Symbol	Parameter	Conditions	Min	Typ	Max	Units
CMOS TO CMOS						
$V_{IN(1)}$	Logical "1" Input Voltage	$V_{CC} = 5V$ $V_{CC} = 10V$	3.5 8.0			V
$V_{IN(0)}$	Logical "0" Input Voltage	$V_{CC} = 5V$ $V_{CC} = 10V$			1.5 2.0	V
$V_{OUT(1)}$	Logical "1" Output Voltage	$V_{CC} = 5V, I_O = -10 \mu A$ $V_{CC} = 10V, I_O = -10 \mu A$	4.5 9.0			V
$V_{OUT(0)}$	Logical "0" Output Voltage	$V_{CC} = 5V, I_O = +10 \mu A$ $V_{CC} = 10V, I_O = +10 \mu A$			0.5 1.0	V
$I_{IN(1)}$	Logical "1" Input Current	$V_{CC} = 15V, V_{IN} = 15V$		0.005	1.0	μA
$I_{IN(0)}$	Logical "0" Input Current	$V_{CC} = 15V, V_{IN} = 0V$	-1.0	-0.005		μA
I_{CC}	Supply Current	$V_{CC} = 15V$		0.05	300	μA

CMOS/LPTTL INTERFACE

$V_{IN(1)}$	Logical "1" Input Voltage MM54C90, MM54C93 MM74C90, MM74C93	$V_{CC} = 4.5V$ $V_{CC} = 4.75V$	$V_{CC} - 1.5$ $V_{CC} - 1.5$			V
$V_{IN(0)}$	Logical "0" Input Voltage MM54C90, MM54C93 MM74C90, MM74C93	$V_{CC} = 4.5V$ $V_{CC} = 4.75V$			0.8 0.8	V
$V_{OUT(1)}$	Logical "1" Output Voltage MM54C90, MM54C93 MM74C90, MM74C93	$V_{CC} = 4.5V, I_O = -360 \mu A$ $V_{CC} = 4.75V, I_O = -360 \mu A$	2.4 2.4			V
$V_{OUT(0)}$	Logical "0" Output Voltage MM54C90, MM54C93 MM74C90, MM74C93	$V_{CC} = 4.5V, I_O = -360 \mu A$ $V_{CC} = 4.75V, I_O = -360 \mu A$			0.4 0.4	V

OUTPUT DRIVE (See 54C/74C Family Characteristics Data Sheet) (Short Circuit Current)

I_{SOURCE}	Output Source Current (P-Channel)	$V_{CC} = 5V, V_{OUT} = 0V$ $T_A = 25^\circ C$	-1.75	-3.3		mA
I_{SOURCE}	Output Source Current (P-Channel)	$V_{CC} = 10V, V_{OUT} = 0V$ $T_A = 25^\circ C$	-8.0	-15		mA
I_{SINK}	Output Sink Current (N-Channel)	$V_{CC} = 5V, V_{OUT} = V_{CC}$ $T_A = 25^\circ C$	1.75	3.6		mA
I_{SINK}	Output Sink Current (N-Channel)	$V_{CC} = 10V, V_{OUT} = V_{CC}$ $T_A = 25^\circ C$	8.0	16		mA

Note 1: "Absolute Maximum Ratings" are those values beyond which the safety of the device cannot be guaranteed. Except for "Operating Temperature Range", they are not meant to imply that the devices should be operated at these limits. The table of "Electrical Characteristics" provides conditions for actual device operation.

AC Electrical Characteristics* $T_A = 25^\circ C, C_L = 50 pF$, unless otherwise specified

Symbol	Parameter	Conditions	Min	Typ	Max	Units
t_{pd0}, t_{pd1}	Propagation Delay Time from A_{IN} to Q_A	$V_{CC} = 5V$ $V_{CC} = 10V$		200 80	400 150	ns
t_{pd0}, t_{pd1}	Propagation Delay Time from A_{IN} to Q_B (MM54C93/MM74C93)	$V_{CC} = 5V$ $V_{CC} = 10V$		450 160	850 300	ns
t_{pd0}, t_{pd1}	Propagation Delay Time from A_{IN} to Q_B (MM54C90/MM74C90)	$V_{CC} = 5V$ $V_{CC} = 10V$		450 160	800 300	ns

AC Electrical Characteristics* $T_A = 25^\circ\text{C}$, $C_L = 50\text{ pF}$, unless otherwise specified (Continued)

Symbol	Parameter	Conditions	Min	Typ	Max	Units
t_{pd0} , t_{pd1}	Propagation Delay Time from A_{IN} to Q_C (MM54C93/MM74C93)	$V_{CC} = 5\text{V}$ $V_{CC} = 10\text{V}$		500 200	1050 400	ns ns
t_{pd0} , t_{pd1}	Propagation Delay Time from A_{IN} to Q_C (MM54C93/MM74C93)	$V_{CC} = 5\text{V}$ $V_{CC} = 10\text{V}$		500 200	1000 400	ns ns
t_{pd0} , t_{pd1}	Propagation Delay Time from A_{IN} to Q_D (MM54C93/MM74C93)	$V_{CC} = 5\text{V}$ $V_{CC} = 10\text{V}$		600 250	1200 500	ns ns
t_{pd0} , t_{pd1}	Propagation Delay Time from A_{IN} to Q_D (MM54C90/MM74C90)	$V_{CC} = 5\text{V}$ $V_{CC} = 10\text{V}$		450 160	800 300	ns ns
t_{pd0} , t_{pd1}	Propagation Delay Time from R_{01} or R_{02} to Q_A , Q_B , Q_C or Q_D (MM54C93/MM74C93)	$V_{CC} = 5\text{V}$ $V_{CC} = 10\text{V}$		150 75	300 150	ns ns
t_{pd0} , t_{pd1}	Propagation Delay Time from R_{01} or R_{02} to Q_A , Q_B , Q_C or Q_D (MM54C90/MM74C90)	$V_{CC} = 5\text{V}$ $V_{CC} = 10\text{V}$		200 75	400 150	ns ns
t_{pd0} , t_{pd1}	Propagation Delay Time from R_{91} or R_{92} to Q_A or Q_D (MM54C90/MM74C90)	$V_{CC} = 5\text{V}$ $V_{CC} = 10\text{V}$		250 100	500 200	ns ns
t_{pw}	Min. R_{01} or R_{02} Pulse Width (MM54C93/MM74C93)	$V_{CC} = 5\text{V}$ $V_{CC} = 10\text{V}$	600 30	250 125		ns ns
t_{pw}	Min. R_{01} or R_{02} Pulse Width (MM54C90/MM74C90)	$V_{CC} = 5\text{V}$ $V_{CC} = 10\text{V}$	600 300	250 125		ns ns
t_{pw}	Min. R_{91} or R_{92} Pulse Width (MM54C90/MM74C90)	$V_{CC} = 5\text{V}$ $V_{CC} = 10\text{V}$	500 250	200 100		ns ns
t_r , t_f	Maximum Clock Rise and Fall Time	$V_{CC} = 10\text{V}$ $V_{CC} = 10\text{V}$			15 5	μs μs
t_w	Minimum Clock Pulse Width	$V_{CC} = 5\text{V}$ $V_{CC} = 10\text{V}$	250 100	100 50		ns ns
f_{MAX}	Maximum Clock Frequency	$V_{CC} = 5\text{V}$ $V_{CC} = 10\text{V}$	2 5			MHz MHz
C_{IN}	Input Capacitance	Any Input (Note 2)		5		pF
C_{PD}	Power Dissipation Capacitance	Per Package (Note 3)		45		pF

*AC Parameters are guaranteed by DC correlated testing.

Note 1: "Absolute Maximum Ratings" are those values beyond which the safety of the device cannot be guaranteed. Except for "Operating Temperature Range", they are not meant to imply that the devices should be operated at these limits. The table of "Electrical Characteristics" provides conditions for actual device operation.

Note 2: Capacitance is guaranteed by periodic testing.

Note 3: C_{PD} determines the no load ac power consumption of any CMOS device. For complete explanation see 54C/74C Family Characteristics application note—AN-90.

AC Test Circuits

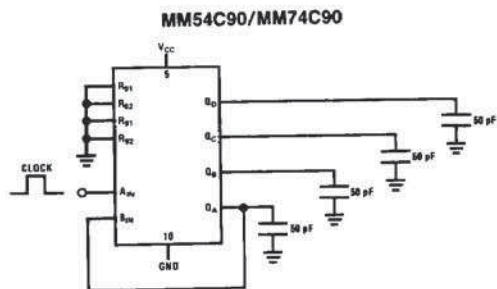

TL/F/5889-5

Clock rise and fall time $t_r = t_f = 20\text{ ns}$

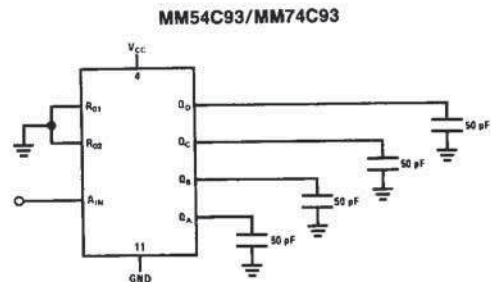

TL/F/5889-6

Clock rise and fall time $t_r = t_f = 20\text{ ns}$

Switching Time Waveforms

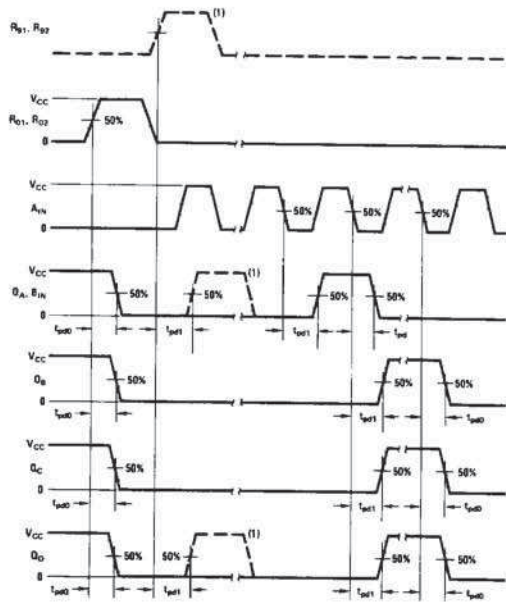

Note 1: MM54C90, MM74C90 and MM54C93, MM74C93 are solid line waveforms. Dashed line waveforms are for MM54C90/MM74C90 only.

TL/F/5889-7

Truth Table

MM54C90/MM74C90 4-Bit Decade Counter

BCD Count Sequence

Count	Output			
	Q _D	Q _C	Q _B	Q _A
0	L	L	L	L
1	L	L	L	H
2	L	L	H	L
3	L	L	H	H
4	L	H	L	L
5	L	H	L	H
6	L	H	H	L
7	L	H	H	H
8	H	L	L	L
9	H	L	L	H

Output Q_A is connected to input B for BCD count.

H = High Level
L = Low Level
X = Irrelevant

Reset/Count Function Table

Reset Inputs				Output			
R ₀₁	R ₀₂	R ₉₁	R ₉₂	Q _D	Q _C	Q _B	Q _A
H	H	L	X	L	L	L	L
H	H	X	L	L	L	L	L
X	X	H	H	H	L	L	H
X	L	X	L	Count			
L	X	L	X	Count			
L	X	X	L	Count			
X	L	L	X	Count			

MM54C93/MM74C93 4-Bit Binary Counter

Binary Count Sequence

Count	Output			
	Q _D	Q _C	Q _B	Q _A
0	L	L	L	L
1	L	L	L	H
2	L	L	H	L
3	L	L	H	H
4	L	H	L	L
5	L	H	L	H
6	L	H	H	L
7	L	H	H	H
8	H	L	L	L
9	H	L	L	H
10	H	L	H	L
11	H	L	H	H
12	H	H	L	L
13	H	H	L	H
14	H	H	H	L
15	H	H	H	H

Output Q_A is connected to input B for binary count sequence.

H = High Level
L = Low Level
X = Irrelevant

Reset/Count Function Table

Reset Inputs		Output			
R ₀₁	R ₀₂	Q _D	Q _C	Q _B	Q _A
H	H	L	L	L	L
L	X	Count			
X	L	Count			