

## **SN5428, SN54LS28, SN7428, SN74LS28**

### *Quadruple 2-Input Positive-NOR Buffers*

These devices contain four independent 2-input NOR buffer gates. The SN5428 and SN54LS28 are characterized for operation over the full military temperature range of -55°C to 125°C while the SN7428 and SN74LS28 are characterized for operation from 0°C to 70°C.

---

#### **Rochester Electronics Manufactured Components**

Rochester branded components are manufactured using either die/wafers purchased from the original suppliers or Rochester wafers recreated from the original IP. All recreations are done with the approval of the OCM.

Parts are tested using original factory test programs or Rochester developed test solutions to guarantee product meets or exceeds the OCM data sheet.

#### **Quality Overview**

- ISO-9001
- AS9120 certification
- Qualified Manufacturers List (QML) MIL-PRF-38535
  - Class Q Military
  - Class V Space Level
- Qualified Suppliers List of Distributors (QSLD)
  - Rochester is a critical supplier to DLA and meets all industry and DLA standards.

Rochester Electronics, LLC is committed to supplying products that satisfy customer expectations for quality and are equal to those originally supplied by industry manufacturers.

---

*The original manufacturer's datasheet accompanying this document reflects the performance and specifications of the Rochester manufactured version of this device. Rochester Electronics guarantees the performance of its semiconductor products to the original OEM specifications. 'Typical' values are for reference purposes only. Certain minimum or maximum ratings may be based on product characterization, design, simulation, or sample testing.*

# SN5428, SN54LS28, SN7428, SN74LS28 QUADRUPLE 2-INPUT POSITIVE-NOR BUFFERS

DECEMBER 1983—REVISED MARCH 1988

- Package Options Include Plastic "Small Outline" Packages, Ceramic Chip Carriers and Flat Packages, and Plastic and Ceramic DIPs
- Dependable Texas Instruments Quality and Reliability

## description

These devices contain four independent 2-input NOR buffer gates.

The SN5428, and SN54LS28 are characterized for operation over the full military temperature range of  $-55^{\circ}\text{C}$  to  $125^{\circ}\text{C}$ . The SN7428, and SN74LS28 are characterized for operation from  $0^{\circ}\text{C}$  to  $70^{\circ}\text{C}$ .

FUNCTION TABLE (each gate)

INPUTS		OUTPUT
A	B	Y
H	X	L
X	H	L
L	L	H

## positive logic

$$Y = \overline{A + B} \text{ or } Y = \overline{A \cdot B}$$

## logic symbol†

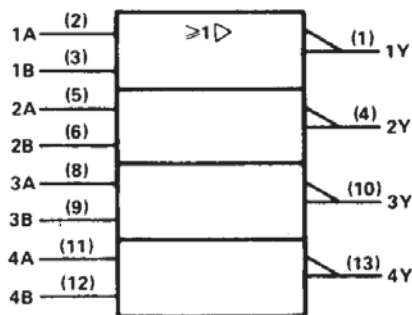

† This symbol is in accordance with ANSI/IEEE Std 91-1984 and IEC Publication 617-12.

Pin numbers shown are for D, J, N, and W packages.

SN5428, SN54LS28 . . . J OR W PACKAGE  
SN7428 . . . N PACKAGE  
SN74LS28 . . . D OR N PACKAGE  
(TOP VIEW)

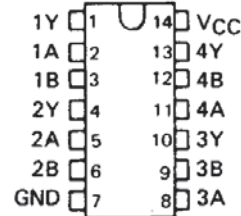

SN54LS28 . . . FK PACKAGE  
(TOP VIEW)

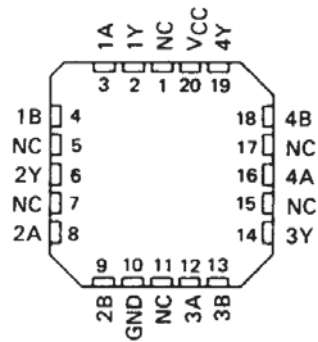

NC - No internal connection

## logic diagram

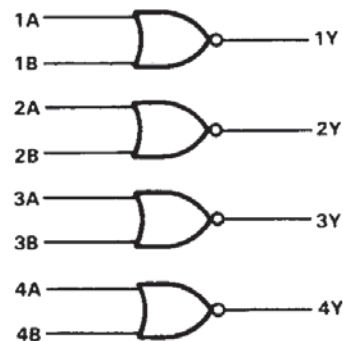

2

TTL Devices

# SN5428, SN54LS28, SN7428, SN74LS28 QUADRUPLE 2-INPUT POSITIVE-NOR BUFFERS

schematics (each gate)

2

TTL Devices

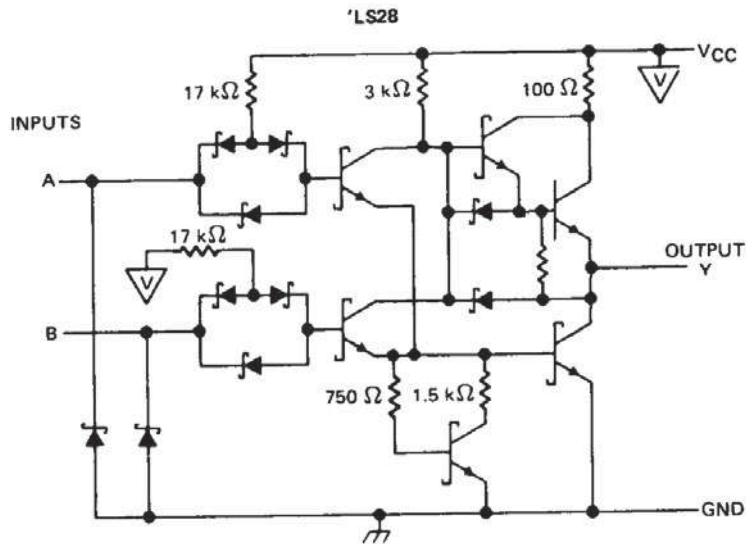
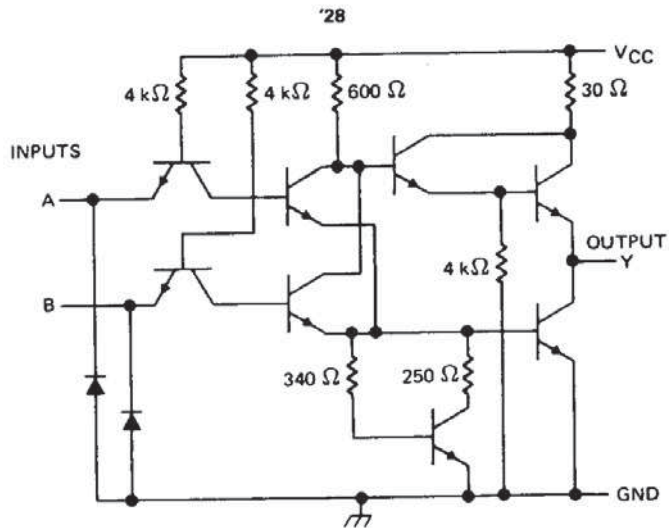

Resistor values shown are nominal.

absolute maximum ratings over operating free-air temperature range (unless otherwise noted)

Supply voltage, $V_{CC}$ (see Note 1) .....	7 V
Input voltage: '28 .....	5.5 V
'LS28 .....	7 V
Operating free-air temperature: SN54' .....	-55°C to 125°C
SN74' .....	0°C to 70°C
Storage temperature range .....	-65°C to 150°C

NOTE 1: Voltage values are with respect to network ground terminal.

# SN5428, SN7428 QUADRUPLE 2-INPUT POSITIVE-NOR BUFFERS

## recommended operating conditions

	SN5428			SN7428			UNIT
	MIN	NOM	MAX	MIN	NOM	MAX	
V <sub>CC</sub> Supply voltage	4.5	5	5.5	4.75	5	5.25	V
V <sub>IH</sub> High-level input voltage	2			2			V
V <sub>IL</sub> Low-level input voltage			0.8			0.8	V
I <sub>OH</sub> High-level output current			-2.4			-2.4	mA
I <sub>OL</sub> Low-level output current			48			48	mA
T <sub>A</sub> Operating free-air temperature	-55		125	0		70	°C

## electrical characteristics over recommended operating free-air temperature range (unless otherwise noted)

PARAMETER	TEST CONDITIONS †	MIN	TYP ‡	MAX	UNIT
V <sub>IK</sub>	V <sub>CC</sub> = MIN, I <sub>I</sub> = -12mA			-1.5	V
V <sub>OH</sub>	V <sub>CC</sub> = MIN, V <sub>IL</sub> = 0.8 V, I <sub>OH</sub> = -2.4 mA	2.4	3.4		V
V <sub>OL</sub>	V <sub>CC</sub> = MIN, V <sub>IH</sub> = 2 V, I <sub>OL</sub> = 48 mA		0.2	0.4	V
I <sub>I</sub>	V <sub>CC</sub> = MAX, V <sub>I</sub> = 5.5 V			1	mA
I <sub>IH</sub>	V <sub>CC</sub> = MAX, V <sub>I</sub> = 2.4 V			40	μA
I <sub>IL</sub>	V <sub>CC</sub> = MAX, V <sub>I</sub> = 0.4 V			-1.6	mA
I <sub>OS</sub> §	V <sub>CC</sub> = MAX	-70		-180	mA
I <sub>CCH</sub>	V <sub>CC</sub> = MAX, V <sub>I</sub> = 0 V		12	21	mA
I <sub>CCL</sub>	V <sub>CC</sub> = MAX, See Note 2		33	57	mA

† For conditions shown as MIN or MAX, use the appropriate value specified under recommended operating conditions.

‡ All typical values are at V<sub>CC</sub> = 5 V, T<sub>A</sub> = 25°C.

§ Not more than one output should be shorted at a time and the duration of the short circuit should not exceed one second.

NOTE 2: One input at 4.5 V, all others at GND.

## switching characteristics, V<sub>CC</sub> = 5 V, T<sub>A</sub> = 25°C (see note 3)

PARAMETER	FROM (INPUT)	TO (OUTPUT)	TEST CONDITIONS	MIN	TYP	MAX	UNIT
t <sub>PLH</sub>	A or B	Y	R <sub>L</sub> = 133 Ω, C <sub>L</sub> = 50 pF		6	9	ns
t <sub>PHL</sub>					8	12	ns
t <sub>PLH</sub>			R <sub>L</sub> = 133 Ω, C <sub>L</sub> = 150 pF		10	15	ns
t <sub>PHL</sub>					12	18	ns

NOTE 3: Load circuits and voltage waveforms are shown in Section 1.

2  
TTL Devices

# SN54LS28, SN74LS28 QUADRUPLE 2-INPUT POSITIVE-NOR BUFFERS

## recommended operating conditions

	SN54LS28			SN74LS28			UNIT
	MIN	NOM	MAX	MIN	NOM	MAX	
V <sub>CC</sub> Supply voltage	4.5	5	5.5	4.75	5	5.25	V
V <sub>IH</sub> High-level input voltage	2			2			V
V <sub>IL</sub> Low-level input voltage			0.7			0.8	V
I <sub>OH</sub> High-level output current			-1.2			-1.2	mA
I <sub>OL</sub> Low-level output current			12			24	mA
T <sub>A</sub> Operating free-air temperature	-55		125	0		70	°C

## electrical characteristics over recommended operating free-air temperature range (unless otherwise noted)

PARAMETER	TEST CONDITIONS †	SN54LS28			SN74LS28			UNIT
		MIN	TYP‡	MAX	MIN	TYP‡	MAX	
V <sub>IK</sub>	V <sub>CC</sub> = MIN, I <sub>I</sub> = -18 mA			-1.5			-1.5	V
V <sub>OH</sub>	V <sub>CC</sub> = MIN, V <sub>IL</sub> = MAX, I <sub>OH</sub> = -1.2 mA	2.5	3.4		2.7	3.4		V
V <sub>OL</sub>	V <sub>CC</sub> = MIN, V <sub>IH</sub> = 2 V, I <sub>OL</sub> = 12 mA	0.25	0.4		0.24	0.4		V
	V <sub>CC</sub> = MIN, V <sub>IH</sub> = 2 V, I <sub>OL</sub> = 24 mA				0.35	0.5		
I <sub>I</sub>	V <sub>CC</sub> = MAX, V <sub>I</sub> = 7 V			0.1			0.1	mA
I <sub>IH</sub>	V <sub>CC</sub> = MAX, V <sub>I</sub> = 2.7 V			20			20	μA
I <sub>IL</sub>	V <sub>CC</sub> = MAX, V <sub>I</sub> = 0.4 V			-0.4			-0.4	mA
I <sub>OS</sub> §	V <sub>CC</sub> = MAX	-30		-130	-30		-130	mA
I <sub>CCH</sub>	V <sub>CC</sub> = MAX, V <sub>I</sub> = 0 V		1.8	3.6		1.8	3.6	mA
I <sub>CCL</sub>	V <sub>CC</sub> = MAX, See Note 2		6.9	13.8		6.9	13.8	mA

† For conditions shown as MIN or MAX, use the appropriate value specified under recommended operating conditions.

‡ All typical values are at V<sub>CC</sub> = 5 V, T<sub>A</sub> = 25°C.

§ Not more than one output should be shorted at a time and the duration of the short circuit should not exceed one second.

NOTE 2: One input at 4.5 V, all others at GND.

## switching characteristics, V<sub>CC</sub> = 5 V, T<sub>A</sub> = 25°C (see note 3)

PARAMETER	FROM (INPUT)	TO (OUTPUT)	TEST CONDITIONS	MIN	TYP	MAX	UNIT
t <sub>PLH</sub>	A or B	Y	R <sub>L</sub> = 667 Ω, C <sub>L</sub> = 45 pF		12	24	ns
t <sub>PHL</sub>					12	24	ns

NOTE 3: Load circuits and voltage waveforms are shown in Section 1.

2

TTL Devices