

SN54HC239, SN74HC239

Dual 2-Line to 4-Line Decoders/Demultiplexers

The 'HC239 circuit is designed to be used in high-performance memory-decoding or data-routing applications requiring very short propagation delay times. In high-performance memory systems this decoder can be used to minimize the effects of system decoding. When employed with high-speed memories utilizing a fast enable circuit, the delay times of this decoder and the enable time of the memory are usually less than the typical access time of the memory. This means that the effective system delay introduced by the decoder is negligible.

Rochester Electronics Manufactured Components

Rochester branded components are manufactured using either die/wafers purchased from the original suppliers or Rochester wafers recreated from the original IP. All recreations are done with the approval of the OCM.

Parts are tested using original factory test programs or Rochester developed test solutions to guarantee product meets or exceeds the OCM data sheet.

Quality Overview

- ISO-9001
- AS9120 certification
- Qualified Manufacturers List (QML) MIL-PRF-38535
 - Class Q Military
 - Class V Space Level
- Qualified Suppliers List of Distributors (QSLD)
 - Rochester is a critical supplier to DLA and meets all industry and DLA standards.

Rochester Electronics, LLC is committed to supplying products that satisfy customer expectations for quality and are equal to those originally supplied by industry manufacturers.

The original manufacturer's datasheet accompanying this document reflects the performance and specifications of the Rochester manufactured version of this device. Rochester Electronics guarantees the performance of its semiconductor products to the original OEM specifications. 'Typical' values are for reference purposes only. Certain minimum or maximum ratings may be based on product characterization, design, simulation, or sample testing.

SN54HC239, SN74HC239 DUAL 2-LINE TO 4-LINE DECODERS/DEMULTIPLEXERS

D2804, MARCH 1984—REVISED JUNE 1989

- Designed Specifically for High-Speed Memory Decoders and Data Transmission Systems
- Incorporates 2 Enable Inputs to Simplify Cascading and/or Data Reception
- Package Options Include Plastic "Small Outline" Packages, Ceramic Chip Carriers, and Standard Plastic and Ceramic 300-mil DIPs
- Dependable Texas Instruments Quality and Reliability

description

The 'HC239 circuit is designed to be used in high-performance memory-decoding or data-routing applications requiring very short propagation delay times. In high-performance memory systems this decoder can be used to minimize the effects of system decoding. When employed with high-speed memories utilizing a fast enable circuit, the delay times of this decoder and the enable time of the memory are usually less than the typical access time of the memory. This means that the effective system delay introduced by the decoder is negligible.

The 'HC239 is comprised of two individual two-line to four-line decoders in a single package. The active-low enable input can be used as a data line in demultiplexing applications. These decoders/demultiplexers feature fully buffered inputs, each of which represents only one normalized load to its driving circuit.

The SN54HC239 is characterized for operation over the full military temperature range of -55°C to 125°C . The SN74HC239 is characterized for operation from -40°C to 85°C .

logic symbols (alternatives)†

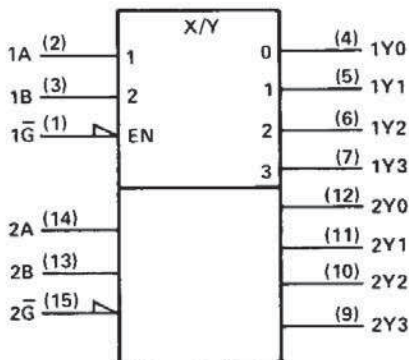

SN54HC239 . . . J PACKAGE
SN74HC239 . . . D† OR N PACKAGE
(TOP VIEW)

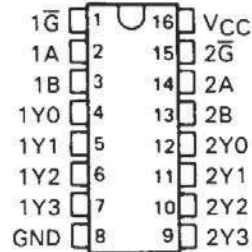

SN54HC239 . . . FK PACKAGE
(TOP VIEW)

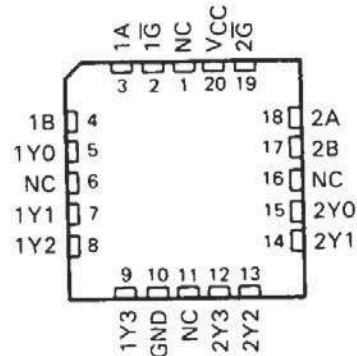

NC—No internal connection

†Contact the factory for D availability

‡These symbols are in accordance with ANSI/IEEE Std 91-1984 and IEC Publication 617-12. Pin numbers shown are for D, J, and N packages.

PRODUCTION DATA documents contain information current as of publication date. Products conform to specifications per the terms of Texas Instruments standard warranty. Production processing does not necessarily include testing of all parameters.

TEXAS
INSTRUMENTS

POST OFFICE BOX 655012 • DALLAS, TEXAS 75265

Copyright © 1989, Texas Instruments Incorporated

2-307

2

HCMOS Devices

SN54HC239, SN74HC239
DUAL 2-LINE TO 4-LINE DECODERS/DEMULTIPLEXERS

logic diagram (positive logic)

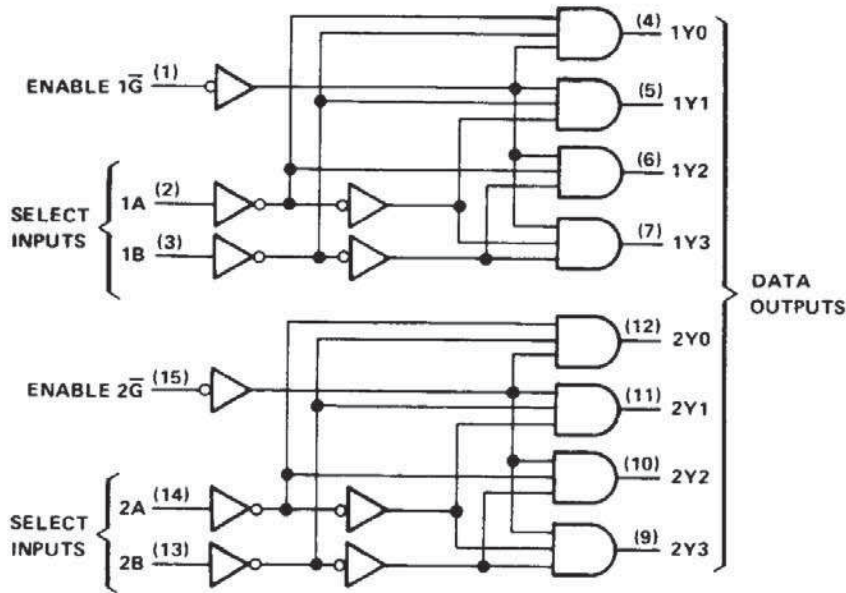

Pin numbers shown are for D, J, and N packages.

FUNCTION TABLE

INPUTS			OUTPUTS			
ENABLE	SELECT		Y0	Y1	Y2	Y3
\bar{G}	B	A				
H	X	X	L	L	L	L
L	L	L	H	L	L	L
L	L	H	L	H	L	L
L	H	L	L	L	H	L
L	H	H	L	L	L	H

absolute maximum ratings over operating free-air temperature range†

- Supply voltage, V_{CC} -0.5 V to 7 V
- Input clamp current, I_{IK} ($V_I < 0$ or $V_I > V_{CC}$) ± 20 mA
- Output clamp current, I_{OK} ($V_O < 0$ or $V_O > V_{CC}$) ± 20 mA
- Continuous output current, I_O ($V_O = 0$ to V_{CC}) ± 25 mA
- Continuous current through V_{CC} or GND pins ± 50 mA
- Lead temperature 1,6 mm (1/16 in) from case for 60 s: FK or J package 300°C
- Lead temperature 1,6 mm (1/16 in) from case for 10 s: D or N package 260°C
- Storage temperature range -65°C to 150°C

† Stresses beyond those listed under "absolute maximum ratings" may cause permanent damage to the device. These are stress ratings only, and functional operation of the device at these or any other conditions beyond those indicated under "recommended operating conditions" is not implied. Exposure to absolute-maximum-rated conditions for extended periods may affect device reliability.

SN54HC239, SN74HC239
DUAL 2-LINE TO 4-LINE DECODERS/DEMULTIPLEXERS

recommended operating conditions

		SN54HC239			SN74HC239			UNIT	
		MIN	NOM	MAX	MIN	NOM	MAX		
V _{CC}	Supply voltage	2	5	6	2	5	6	V	
V _{IH}	High-level input voltage	V _{CC} = 2 V		1.5	1.5		V		
		V _{CC} = 4.5 V		3.15	3.15				
		V _{CC} = 6 V		4.2	4.2				
V _{IL}	Low-level input voltage	V _{CC} = 2 V		0	0.3		V		
		V _{CC} = 4.5 V		0	0.9				
		V _{CC} = 6 V		0	1.2				
V _I	Input voltage			0	V _{CC}		V		
V _O	Output voltage			0	V _{CC}		V		
t _t	Input transition (rise and fall) times	V _{CC} = 2 V		0	1000		ns		
		V _{CC} = 4.5 V		0	500				
		V _{CC} = 6 V		0	400				
T _A	Operating free-air temperature	-55		125		-40		85	°C

2

HCMOS Devices

electrical characteristics over recommended operating free-air temperature range (unless otherwise noted)

PARAMETER	TEST CONDITIONS	V _{CC}	T _A = 25°C			SN54HC239		SN74HC239		UNIT
			MIN	TYP	MAX	MIN	MAX	MIN	MAX	
V _{OH}	V _I = V _{IH} or V _{IL} , I _{OH} = -20 μA	2 V	1.9	1.998		1.9	1.9	V		
		4.5 V	4.4	4.499		4.4	4.4			
		6 V	5.9	5.999		5.9	5.9			
	4.5 V	3.98	4.30		3.7	3.84				
	V _I = V _{IH} or V _{IL} , I _{OH} = -5.2 mA	6 V	5.48	5.80		5.2	5.34			
V _{OL}	V _I = V _{IH} or V _{IL} , I _{OL} = 20 μA	2 V	0.002	0.1		0.1	0.1	V		
		4.5 V	0.001	0.1		0.1	0.1			
		6 V	0.001	0.1		0.1	0.1			
	4.5 V	0.17	0.26		0.4	0.33				
	V _I = V _{IH} or V _{IL} , I _{OL} = 5.2 mA	6 V	0.15	0.26		0.4	0.33			
I _I	V _I = V _{CC} or 0	6 V	±0.1 ±100			±1000		±1000		nA
I _{CC}	V _I = V _{CC} or 0, I _O = 0	6 V				160		80		μA
C _i		2 to 6 V	3 10			10		10		pF

switching characteristics over recommended operating free-air temperature range (unless otherwise noted), C_L = 50 pF (see Note 1)

PARAMETER	FROM (INPUT)	TO (OUTPUT)	V _{CC}	T _A = 25°C			SN54HC239		SN74HC239		UNIT
				MIN	TYP	MAX	MIN	MAX	MIN	MAX	
t _{pd}	A or B	Y	2 V	62 150			225		190		ns
			4.5 V	18 30			45		38		
			6 V	14 26			38		32		
t _{pd}	̄C	Y	2 V	53 120			180		150		ns
			4.5 V	14 24			36		30		
			6 V	11 20			31		26		
t _{pd}		Y	2 V	38 75			110		95		ns
			4.5 V	8 15			22		19		
			6 V	6 13			19		16		

C _{pd}	Power dissipation capacitance per decoder	No load, T _A = 25°C	25 pF typ
-----------------	---	--------------------------------	-----------

NOTE 1: Load circuit and voltage waveforms are shown in Section 1.