

SN54S64, SN54S65, SN74S64, SN74S65

4-2-3-2 Input AND-OR-INVERT Gates

These devices contain 4-2-3-2 input AND-OR-INVERT gates. They perform the Boolean function $Y=ABCD+EF+GHI+JK$. The 'S64 has totem-pole outputs and the 'S65 has open-collector outputs. The SN54S64 and the SN54S65 are characterized for operation over the full military temperature range of -55°C to 125°C while the SN74S64 and the SN74S65 are characterized for operation from 0°C to 70°C.

Rochester Electronics Manufactured Components

Rochester branded components are manufactured using either die/wafers purchased from the original suppliers or Rochester wafers recreated from the original IP. All recreations are done with the approval of the OCM.

Parts are tested using original factory test programs or Rochester developed test solutions to guarantee product meets or exceeds the OCM data sheet.

Quality Overview

- ISO-9001
- AS9120 certification
- Qualified Manufacturers List (QML) MIL-PRF-38535
 - Class Q Military
 - Class V Space Level
- Qualified Suppliers List of Distributors (QSLD)
 - Rochester is a critical supplier to DLA and meets all industry and DLA standards.

Rochester Electronics, LLC is committed to supplying products that satisfy customer expectations for quality and are equal to those originally supplied by industry manufacturers.

The original manufacturer's datasheet accompanying this document reflects the performance and specifications of the Rochester manufactured version of this device. Rochester Electronics guarantees the performance of its semiconductor products to the original OEM specifications. 'Typical' values are for reference purposes only. Certain minimum or maximum ratings may be based on product characterization, design, simulation, or sample testing.

**SN54S64, SN54S65,
SN74S64, SN74S65**
4-2-3-2 INPUT AND-OR-INVERT GATES
SDLS205 - DECEMBER 1983 - REVISED MARCH 1988

- Package Options Include Plastic "Small Outline" Packages, Ceramic Chip Carriers and Flat Packages, and Plastic and Ceramic DIPs

- Dependable Texas Instruments Quality and Reliability

description

These devices contain 4-2-3-2 input AND-OR-INVERT gates. They perform the Boolean function $Y = \overline{ABCD + EF + GHI + JK}$. The 'S64 has totem-pole outputs and the 'S65 has open-collector outputs.

The SN54S64 and the SN54S65 are characterized for operation over the full military temperature range of -55°C to 125°C. The SN74S64 and the SN74S65 are characterized for operation from 0°C to 70°C.

logic symbols†

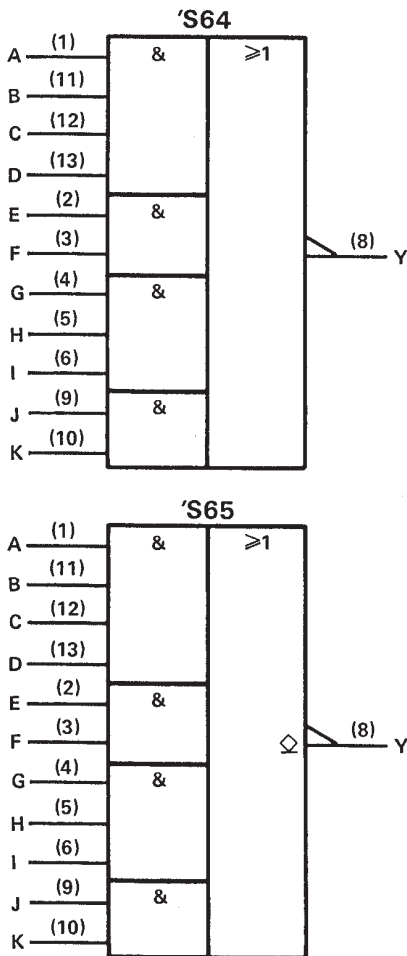

†These symbols are in accordance with ANSI/IEEE Std 91-1984 and IEC Publication 617-12. Pin numbers shown are for D, J, N, and W packages.

SN54S64, SN54S65 . . . J OR W PACKAGE
SN74S64, SN74S65 . . . D OR N PACKAGE
(TOP VIEW)

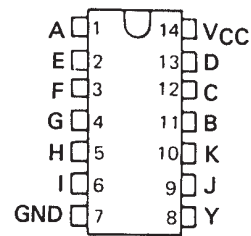

SN54S64, SN54S65 . . . FK PACKAGE
(TOP VIEW)

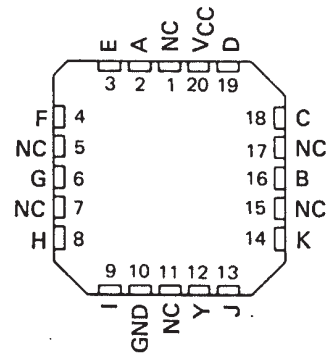

NC - No internal connection

logic diagram (each device) (positive logic)

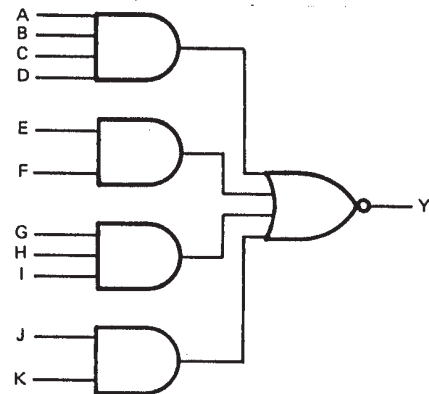

**SN54S64, SN54S65,
SN74S64, SN74S65**
4-2-3-2 INPUT AND-OR-INVERT GATES

SDLS205 – DECEMBER 1983 – REVISED MARCH 1988

schematics (each gate)

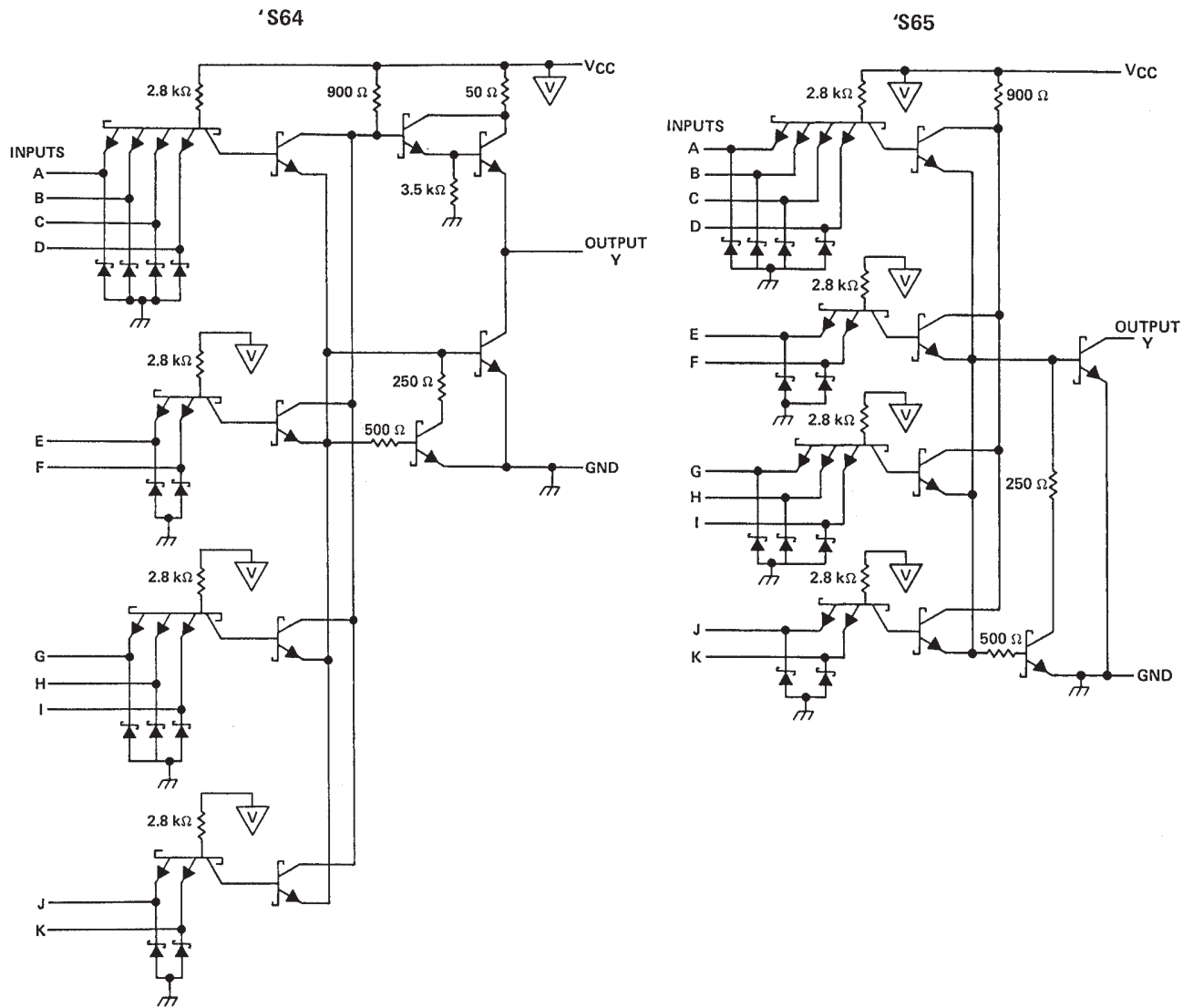

Resistor values shown are nominal and in ohms.

absolute maximum ratings over operating free-air temperature range (unless otherwise noted)

Supply voltage, V_{CC} (see Note 1)	7 V
Input voltage	5.5 V
Off-state output voltage, 'S65	7 V
Operating free-air temperature range: SN54'	-55°C to 125°C
SN74'	0°C to 70°C
Storage temperature range	-65°C to 150°C



POST OFFICE BOX 655303 • DALLAS, TEXAS 75265

SN54S64, SN54S65 4-2-3-2 INPUT AND-OR-INVERT GATES

SDLS205 – DECEMBER 1983 – REVISED MARCH 1988

recommended operating conditions

	SN54S64			SN74S64			UNIT
	MIN	NOM	MAX	MIN	NOM	MAX	
V_{CC} Supply voltage	4.5	5	5.5	4.75	5	5.25	V
V_{IH} High-level input voltage	2			2			V
V_{IL} Low-level input voltage			0.8			0.8	V
I_{OH} High-level output current			-1			-1	mA
I_{OL} Low-level output current			20			20	mA
T_A Operating free-air temperature	-55		125	0		70	°C

electrical characteristics over recommended operating free-air temperature range (unless otherwise noted)

PARAMETER	TEST CONDITIONS †	SN54S64		SN74S64		UNIT		
		MIN	TYP ‡	MAX	MIN		TYP ‡	MAX
V_{IK}	$V_{CC} = \text{MIN}, I_I = -18 \text{ mA}$			-1.2		-1.2	V	
V_{OH}	$V_{CC} = \text{MIN}, V_{IL} = 0.8 \text{ V}, I_{OH} = -1 \text{ mA}$	2.5	3.4		2.7	3.4	V	
V_{OL}	$V_{CC} = \text{MIN}, V_{IH} = 2 \text{ V}, I_{OL} = 20 \text{ mA}$			0.5		0.5	V	
I_I	$V_{CC} = \text{MAX}, V_I = 5.5 \text{ V}$			1		1	mA	
I_{IH}	$V_{CC} = \text{MAX}, V_I = 2.7 \text{ V}$			50		50	μA	
I_{IL}	$V_{CC} = \text{MAX}, V_I = 0.5 \text{ V}$			-2		-2	mA	
$I_{OS} §$	$V_{CC} = \text{MAX}$	-40		-100	-40	-100	mA	
I_{CCH}	$V_{CC} = \text{MAX}, V_I = 0$		7	12.5		7	12.5	mA
I_{CCL}	$V_{CC} = \text{MAX}, V_I = 4.5 \text{ V}$		8.5	16		8.5	16	mA

† For conditions shown as MIN or MAX, use the appropriate value specified under recommended operating conditions.

‡ All typical values are at $V_{CC} = 5 \text{ V}, T_A = 25^\circ \text{C}$.

§ Not more than one output should be shorted at a time, and the duration of the short-circuit should not exceed one second.

switching characteristics, $V_{CC} = 5 \text{ V}, T_A = 25^\circ \text{C}$ (see note 2)

PARAMETER	FROM (INPUT)	TO (OUTPUT)	TEST CONDITIONS	MIN	TYP	MAX	UNIT	
t_{PLH}	Any	Y	$R_L = 280 \Omega, C_L = 15 \text{ pF}$		3.5	5.5	ns	
t_{PHL}					3.5	5.5	ns	
t_{PLH}			$R_L = 280 \Omega, C_L = 50 \text{ pF}$			5		ns
t_{PHL}						5.5		ns

NOTE 2: Load circuits and voltage waveforms are shown in Section 1.

SN54S65, SN74S65

4-2-3-2 INPUT AND-OR-INVERT GATES

SDLS205 – DECEMBER 1983 – REVISED MARCH 1988

recommended operating conditions

	SN54S65			SN74S65			UNIT
	MIN	NOM	MAX	MIN	NOM	MAX	
V _{CC} Supply voltage	4.5	5	5.5	4.75	5	5.25	V
V _{IH} High-level input voltage	2			2			V
V _{IL} Low-level input voltage			0.8			0.8	V
V _{OH} High-level output voltage			5.5			5.5	V
I _{OL} Low-level output current			20			20	mA
T _A Operating free-air temperature	-55		125	0		70	°C

electrical characteristics over recommended operating free-air temperature range (unless otherwise noted)

PARAMETER	TEST CONDITIONS†	SN54S65			SN74S65			UNIT	
		MIN	TYP‡	MAX	MIN	TYP‡	MAX		
V _{IK}	V _{CC} = MIN, I _I = -18 mA			1.2			1.2	V	
I _{OH}	V _{CC} = MIN, V _{IL} = 0.8 V, V _{OH} = 5.5 V						0.25	mA	
	V _{CC} = MIN, V _{IL} = 0.7 V, V _{OH} = 5.5 V			0.25					
V _{OL}	V _{CC} = MIN, V _{IH} = 2 V, I _{OL} = 20 mA	0.2	0.4		0.2	0.4		V	
I _I	V _{CC} = MAX, V _I = 5.5 V			1			1	mA	
I _{IH}	V _{CC} = MAX, V _I = 2.7 V			50			50	μA	
I _{IL}	V _{CC} = MAX, V _I = 0.5 V			-2			-2	mA	
I _{CCH}	V _{CC} = MAX, V _I = 0			6	11		6	11	mA
I _{CCL}	V _{CC} = MAX, V _I = 4.5 V			8.5	16		8.5	16	mA

†For conditions shown as MIN or MAX, use the appropriate value specified under recommended operating conditions.

‡All typical values are at V_{CC} = 5 V, T_A = 25°C.

switching characteristics, V_{CC} = 5 V, T_A = 25°C (see note 2)

PARAMETER	FROM (INPUT)	TO (OUTPUT)	TEST CONDITIONS		MIN	TYP	MAX	UNIT
t _{PLH}	Any	Y	R _L = 280 Ω,	C _L = 15 pF	2	5	7.5	ns
t _{PHL}					2	5.5	8.5	ns
t _{PLH}			R _L = 280 Ω,	C _L = 50 pF	8		ns	
t _{PHL}					6.5		ns	

NOTE 2: Load circuits and voltage waveforms are shown in Section 1.



PACKAGING INFORMATION

Orderable Device	Status ⁽¹⁾	Package Type	Package Drawing	Pins	Package Qty	Eco Plan ⁽²⁾	Lead/Ball Finish	MSL Peak Temp ⁽³⁾
JM38510/07402BCA	ACTIVE	CDIP	J	14	1	TBD	A42	N / A for Pkg Type
JM38510/07402BDA	ACTIVE	CFP	W	14	1	TBD	A42	N / A for Pkg Type
SN54S64J	ACTIVE	CDIP	J	14	1	TBD	A42	N / A for Pkg Type
SN74S64D	OBSOLETE	SOIC	D	14		TBD	Call TI	Call TI
SN74S64DR	OBSOLETE	SOIC	D	14		TBD	Call TI	Call TI
SN74S64N	OBSOLETE	PDIP	N	14		TBD	Call TI	Call TI
SN74S64N3	OBSOLETE	PDIP	N	14		TBD	Call TI	Call TI
SN74S65D	OBSOLETE	SOIC	D	14		TBD	Call TI	Call TI
SN74S65DR	OBSOLETE	SOIC	D	14		TBD	Call TI	Call TI
SN74S65N	OBSOLETE	PDIP	N	14		TBD	Call TI	Call TI
SNJ54S64FK	ACTIVE	LCCC	FK	20	1	TBD	POST-PLATE	N / A for Pkg Type
SNJ54S64J	ACTIVE	CDIP	J	14	1	TBD	A42	N / A for Pkg Type
SNJ54S64W	ACTIVE	CFP	W	14	1	TBD	A42	N / A for Pkg Type

⁽¹⁾ The marketing status values are defined as follows:

ACTIVE: Product device recommended for new designs.

LIFEBUY: TI has announced that the device will be discontinued, and a lifetime-buy period is in effect.

NRND: Not recommended for new designs. Device is in production to support existing customers, but TI does not recommend using this part in a new design.

PREVIEW: Device has been announced but is not in production. Samples may or may not be available.

OBSOLETE: TI has discontinued the production of the device.

⁽²⁾ Eco Plan - The planned eco-friendly classification: Pb-Free (RoHS), Pb-Free (RoHS Exempt), or Green (RoHS & no Sb/Br) - please check <http://www.ti.com/productcontent> for the latest availability information and additional product content details.

TBD: The Pb-Free/Green conversion plan has not been defined.

Pb-Free (RoHS): TI's terms "Lead-Free" or "Pb-Free" mean semiconductor products that are compatible with the current RoHS requirements for all 6 substances, including the requirement that lead not exceed 0.1% by weight in homogeneous materials. Where designed to be soldered at high temperatures, TI Pb-Free products are suitable for use in specified lead-free processes.

Pb-Free (RoHS Exempt): This component has a RoHS exemption for either 1) lead-based flip-chip solder bumps used between the die and package, or 2) lead-based die adhesive used between the die and leadframe. The component is otherwise considered Pb-Free (RoHS compatible) as defined above.

Green (RoHS & no Sb/Br): TI defines "Green" to mean Pb-Free (RoHS compatible), and free of Bromine (Br) and Antimony (Sb) based flame retardants (Br or Sb do not exceed 0.1% by weight in homogeneous material)

⁽³⁾ MSL, Peak Temp. -- The Moisture Sensitivity Level rating according to the JEDEC industry standard classifications, and peak solder temperature.

Important Information and Disclaimer: The information provided on this page represents TI's knowledge and belief as of the date that it is provided. TI bases its knowledge and belief on information provided by third parties, and makes no representation or warranty as to the accuracy of such information. Efforts are underway to better integrate information from third parties. TI has taken and continues to take reasonable steps to provide representative and accurate information but may not have conducted destructive testing or chemical analysis on incoming materials and chemicals. TI and TI suppliers consider certain information to be proprietary, and thus CAS numbers and other limited information may not be available for release.

In no event shall TI's liability arising out of such information exceed the total purchase price of the TI part(s) at issue in this document sold by TI to Customer on an annual basis.

J (R-GDIP-T**)

14 LEADS SHOWN

CERAMIC DUAL IN-LINE PACKAGE



DIM \ PINS **	14	16	18	20
A	0.300 (7,62) BSC	0.300 (7,62) BSC	0.300 (7,62) BSC	0.300 (7,62) BSC
B MAX	0.785 (19,94)	.840 (21,34)	0.960 (24,38)	1.060 (26,92)
B MIN	—	—	—	—
C MAX	0.300 (7,62)	0.300 (7,62)	0.310 (7,87)	0.300 (7,62)
C MIN	0.245 (6,22)	0.245 (6,22)	0.220 (5,59)	0.245 (6,22)



4040083/F 03/03

- NOTES:
- All linear dimensions are in inches (millimeters).
 - This drawing is subject to change without notice.
 - This package is hermetically sealed with a ceramic lid using glass frit.
 - Index point is provided on cap for terminal identification only on press ceramic glass frit seal only.
 - Falls within MIL STD 1835 GDIP1-T14, GDIP1-T16, GDIP1-T18 and GDIP1-T20.

W (R-GDFP-F14)

CERAMIC DUAL FLATPACK

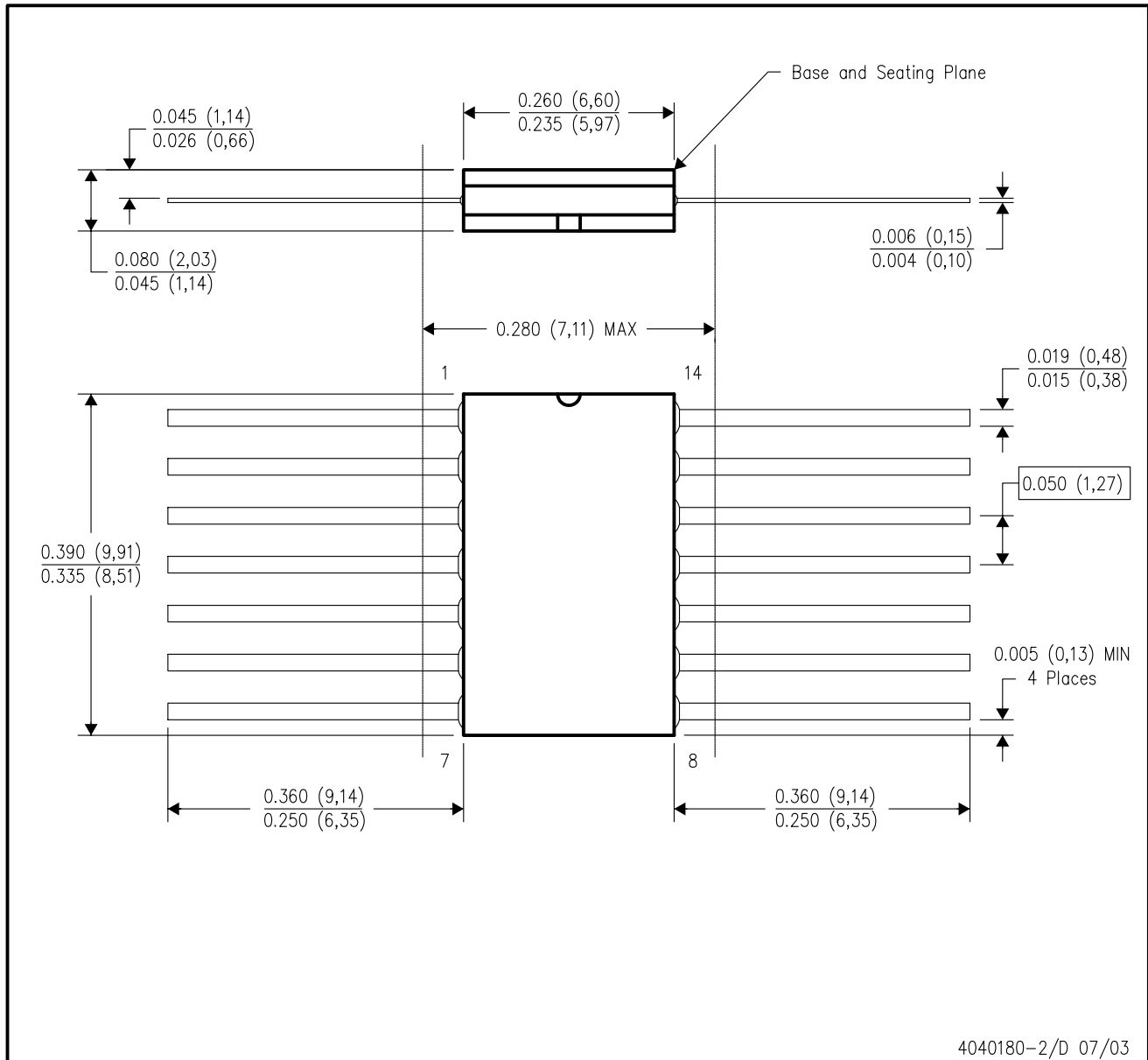

- NOTES:
- A. All linear dimensions are in inches (millimeters).
 - B. This drawing is subject to change without notice.
 - C. This package can be hermetically sealed with a ceramic lid using glass frit.
 - D. Index point is provided on cap for terminal identification only.
 - E. Falls within MIL STD 1835 GDFP1-F14 and JEDEC MO-092AB

FK (S-CQCC-N**)

LEADLESS CERAMIC CHIP CARRIER

28 TERMINAL SHOWN

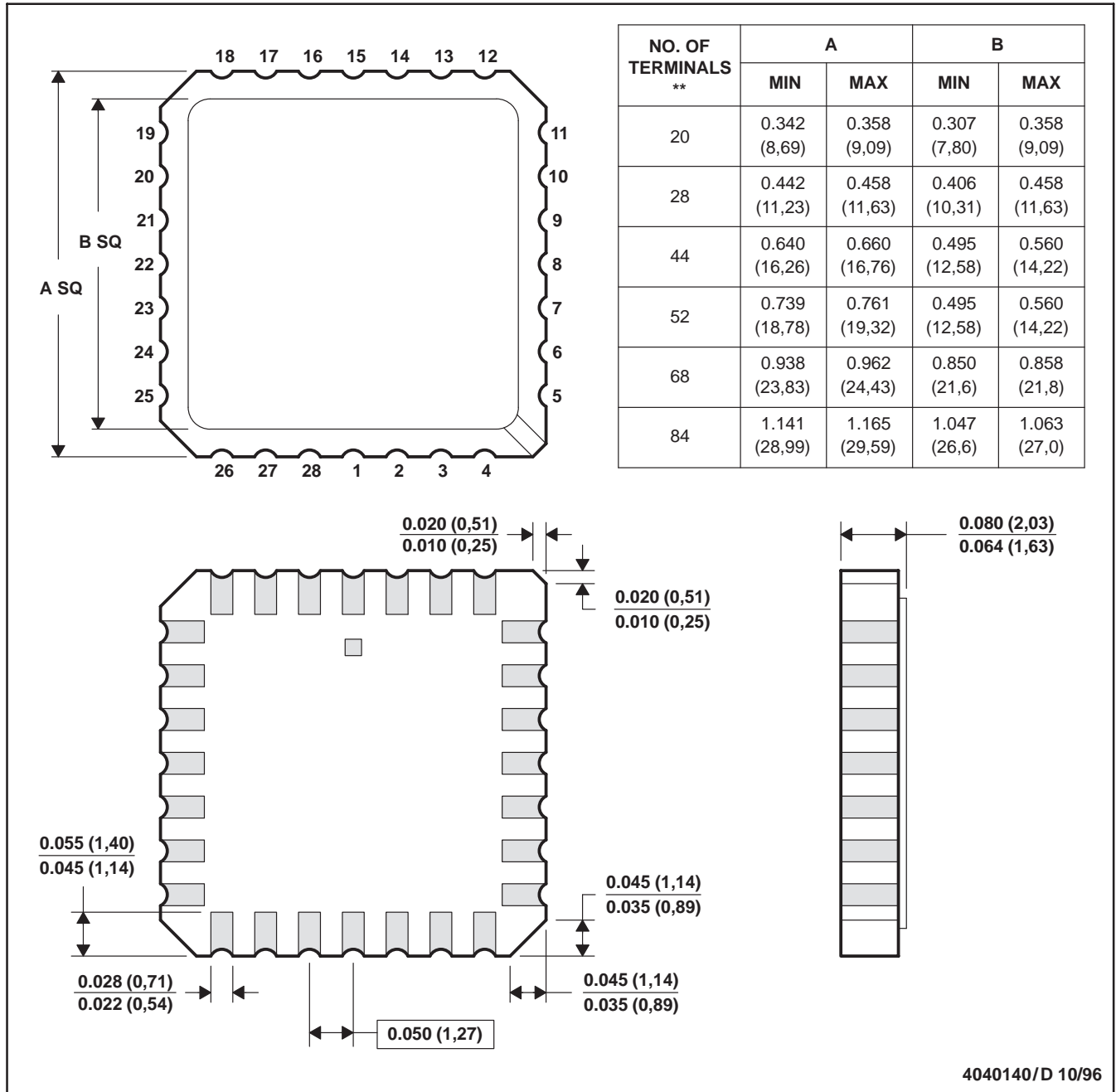

- NOTES:
- A. All linear dimensions are in inches (millimeters).
 - B. This drawing is subject to change without notice.
 - C. This package can be hermetically sealed with a metal lid.
 - D. The terminals are gold plated.
 - E. Falls within JEDEC MS-004

N (R-PDIP-T**)

PLASTIC DUAL-IN-LINE PACKAGE

16 PINS SHOWN



- NOTES:
- A. All linear dimensions are in inches (millimeters).
 - B. This drawing is subject to change without notice.
 - $\triangle C$ Falls within JEDEC MS-001, except 18 and 20 pin minimum body length (Dim A).
 - $\triangle D$ The 20 pin end lead shoulder width is a vendor option, either half or full width.

4040049/E 12/2002

D (R-PDSO-G14)

PLASTIC SMALL-OUTLINE PACKAGE

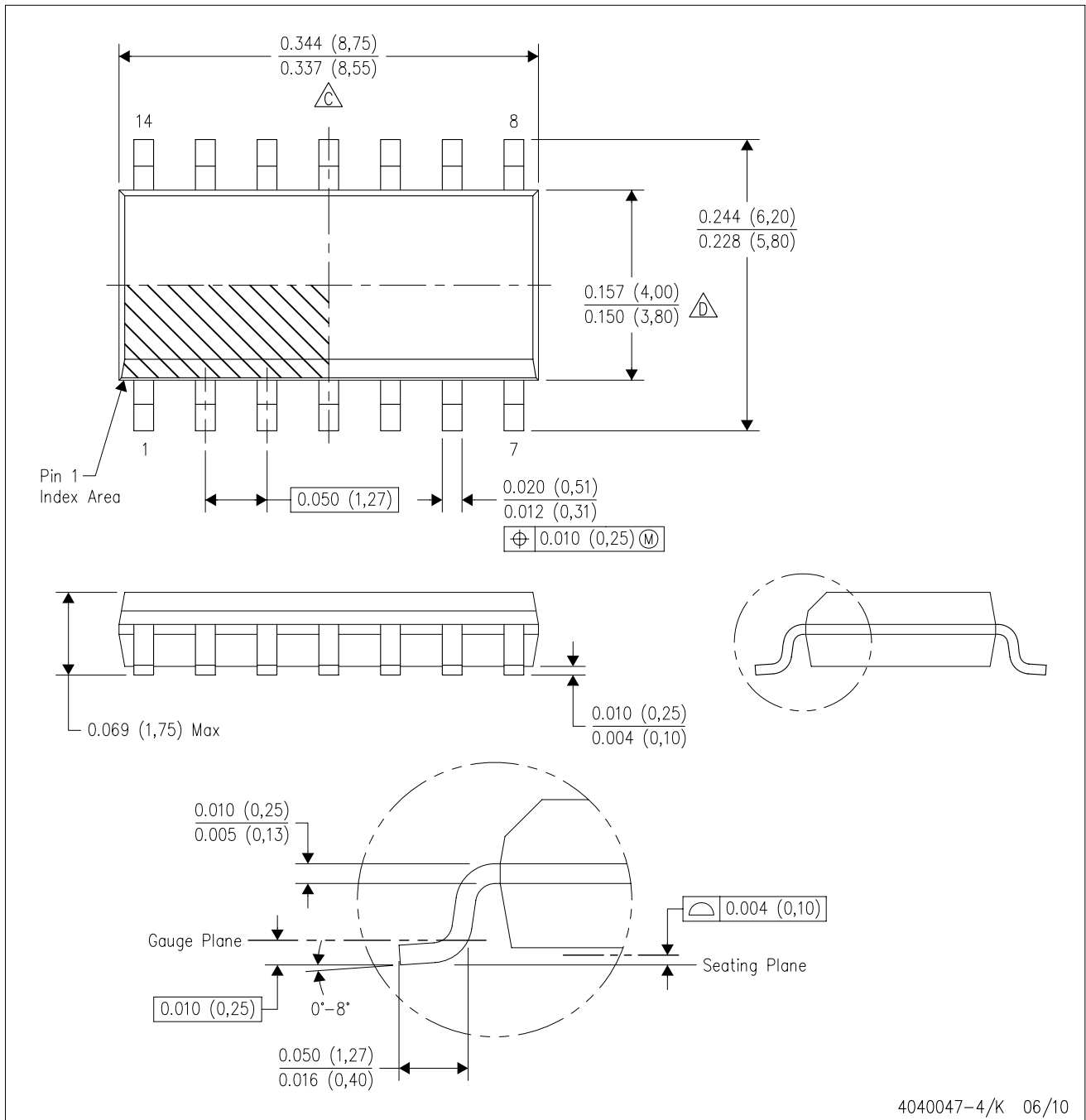

- NOTES:
- A. All linear dimensions are in inches (millimeters).
 - B. This drawing is subject to change without notice.
 - $\triangle C$ Body length does not include mold flash, protrusions, or gate burrs. Mold flash, protrusions, or gate burrs shall not exceed .006 (0,15) per end.
 - $\triangle D$ Body width does not include interlead flash. Interlead flash shall not exceed .017 (0,43) per side.
 - E. Reference JEDEC MS-012 variation AB.

IMPORTANT NOTICE

Texas Instruments Incorporated and its subsidiaries (TI) reserve the right to make corrections, modifications, enhancements, improvements, and other changes to its products and services at any time and to discontinue any product or service without notice. Customers should obtain the latest relevant information before placing orders and should verify that such information is current and complete. All products are sold subject to TI's terms and conditions of sale supplied at the time of order acknowledgment.

TI warrants performance of its hardware products to the specifications applicable at the time of sale in accordance with TI's standard warranty. Testing and other quality control techniques are used to the extent TI deems necessary to support this warranty. Except where mandated by government requirements, testing of all parameters of each product is not necessarily performed.

TI assumes no liability for applications assistance or customer product design. Customers are responsible for their products and applications using TI components. To minimize the risks associated with customer products and applications, customers should provide adequate design and operating safeguards.

TI does not warrant or represent that any license, either express or implied, is granted under any TI patent right, copyright, mask work right, or other TI intellectual property right relating to any combination, machine, or process in which TI products or services are used. Information published by TI regarding third-party products or services does not constitute a license from TI to use such products or services or a warranty or endorsement thereof. Use of such information may require a license from a third party under the patents or other intellectual property of the third party, or a license from TI under the patents or other intellectual property of TI.

Reproduction of TI information in TI data books or data sheets is permissible only if reproduction is without alteration and is accompanied by all associated warranties, conditions, limitations, and notices. Reproduction of this information with alteration is an unfair and deceptive business practice. TI is not responsible or liable for such altered documentation. Information of third parties may be subject to additional restrictions.

Resale of TI products or services with statements different from or beyond the parameters stated by TI for that product or service voids all express and any implied warranties for the associated TI product or service and is an unfair and deceptive business practice. TI is not responsible or liable for any such statements.

TI products are not authorized for use in safety-critical applications (such as life support) where a failure of the TI product would reasonably be expected to cause severe personal injury or death, unless officers of the parties have executed an agreement specifically governing such use. Buyers represent that they have all necessary expertise in the safety and regulatory ramifications of their applications, and acknowledge and agree that they are solely responsible for all legal, regulatory and safety-related requirements concerning their products and any use of TI products in such safety-critical applications, notwithstanding any applications-related information or support that may be provided by TI. Further, Buyers must fully indemnify TI and its representatives against any damages arising out of the use of TI products in such safety-critical applications.

TI products are neither designed nor intended for use in military/aerospace applications or environments unless the TI products are specifically designated by TI as military-grade or "enhanced plastic." Only products designated by TI as military-grade meet military specifications. Buyers acknowledge and agree that any such use of TI products which TI has not designated as military-grade is solely at the Buyer's risk, and that they are solely responsible for compliance with all legal and regulatory requirements in connection with such use.

TI products are neither designed nor intended for use in automotive applications or environments unless the specific TI products are designated by TI as compliant with ISO/TS 16949 requirements. Buyers acknowledge and agree that, if they use any non-designated products in automotive applications, TI will not be responsible for any failure to meet such requirements.

Following are URLs where you can obtain information on other Texas Instruments products and application solutions:

Products		Applications	
Amplifiers	amplifier.ti.com	Audio	www.ti.com/audio
Data Converters	dataconverter.ti.com	Automotive	www.ti.com/automotive
DLP® Products	www.dlp.com	Communications and Telecom	www.ti.com/communications
DSP	dsp.ti.com	Computers and Peripherals	www.ti.com/computers
Clocks and Timers	www.ti.com/clocks	Consumer Electronics	www.ti.com/consumer-apps
Interface	interface.ti.com	Energy	www.ti.com/energy
Logic	logic.ti.com	Industrial	www.ti.com/industrial
Power Mgmt	power.ti.com	Medical	www.ti.com/medical
Microcontrollers	microcontroller.ti.com	Security	www.ti.com/security
RFID	www.ti-rfid.com	Space, Avionics & Defense	www.ti.com/space-avionics-defense
RF/IF and ZigBee® Solutions	www.ti.com/lprf	Video and Imaging	www.ti.com/video
		Wireless	www.ti.com/wireless-apps

Mailing Address: Texas Instruments, Post Office Box 655303, Dallas, Texas 75265
Copyright © 2010, Texas Instruments Incorporated