

SN54L98

4-Bit Data Selectors/Storage Registers

These monolithic data selectors/storage registers are composed of four S-R master-slave flip-flops, four AND-OR-INVERT gates, one buffer, and six inverter/drivers. When the word select input is low, word 1 (A1, B1, C1, D1) is applied to the flip-flops. A high input to word select will cause the selection of word 2 (A2, B2, C2, D2). The selected word is shifted to the output terminals on the negative-going edge of the clock pulse.

Typical power dissipation is 25 mW. The SN54L98 is characterized for operation over the full military temperature range of -55°C to 125°C.

Rochester Electronics Manufactured Components

Rochester branded components are manufactured using either die/wafers purchased from the original suppliers or Rochester wafers recreated from the original IP. All recreations are done with the approval of the OCM.

Parts are tested using original factory test programs or Rochester developed test solutions to guarantee product meets or exceeds the OCM data sheet.

Quality Overview

- ISO-9001
- AS9120 certification
- Qualified Manufacturers List (QML) MIL-PRF-38535
 - Class Q Military
 - Class V Space Level
- Qualified Suppliers List of Distributors (QSLD)
 - Rochester is a critical supplier to DLA and meets all industry and DLA standards.

Rochester Electronics, LLC is committed to supplying products that satisfy customer expectations for quality and are equal to those originally supplied by industry manufacturers.

The original manufacturer's datasheet accompanying this document reflects the performance and specifications of the Rochester manufactured version of this device. Rochester Electronics guarantees the performance of its semiconductor products to the original OEM specifications. 'Typical' values are for reference purposes only. Certain minimum or maximum ratings may be based on product characterization, design, simulation, or sample testing.

TYPE SN54L98 4-BIT DATA SELECTORS/STORAGE REGISTERS

DECEMBER 1972 - REVISED DECEMBER 1983

- Dependable Texas Instruments Quality and Reliability

description

These monolithic data selectors/storage registers are composed of four S-R master-slave flip-flops, four AND-OR-INVERT gates, one buffer, and six inverter/drivers.

When the word select input is low, word 1 (A1, B1, C1, D1) is applied to the flip-flops. A high input to word select will cause the selection of word 2 (A2, B2, C2, D2). The selected word is shifted to the output terminals on the negative-going edge of the clock pulse.

Typical power dissipation is 25 mW. The SN54L98 is characterized for operation over the full military temperature range of -55°C to 125°C .

SN54L98 ... J PACKAGE
(TOP VIEW)

A2	1	16	V _{CC}
A1	2	15	Q _A
B1	3	14	Q _B
B2	4	13	Q _C
C1	5	12	D1
C2	6	11	Q _D
D2	7	10	CLK
GND	8	9	WS

3

TTL DEVICES

logic diagram

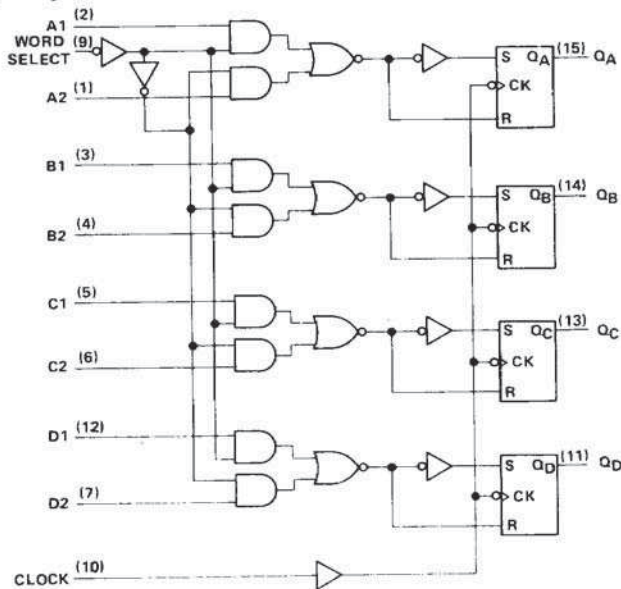

schematics of inputs and outputs

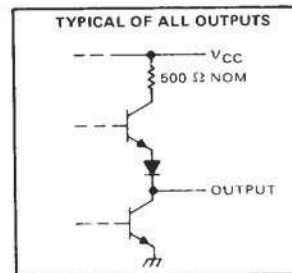
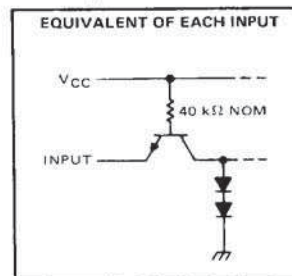

3-400

PRODUCTION DATA
This document contains information current as of publication date. Products conform to specifications per the terms of Texas Instruments standard warranty. Production processing does not necessarily include testing of all parameters.

TEXAS INSTRUMENTS
POST OFFICE BOX 225012 • DALLAS, TEXAS 75265

TYPE SN54L98
4-BIT DATA SELECTORS/STORAGE REGISTERS

absolute maximum ratings over operating free-air temperature range (unless otherwise noted)

Supply voltage, V_{CC} (see Note 1)	8 V
Input voltage (see Note 2)	5.5 V
Operating free-air temperature range: SN54L98	-55°C to 125°C
Storage temperature range	-65°C to 150°C

NOTES: 1. Voltage values are with respect to network ground terminal.
2. Input voltages must be zero or positive with respect to network ground terminal.

recommended operating conditions

		SN54L98			UNIT
		MIN	NOM	MAX	
V_{CC}	Supply voltage	4.5	5	5.5	V
V_{IH}	High-level input voltage	2			V
V_{IL}	Low-level input voltage			0.7	V
I_{OH}	High-level output current			-0.1	mA
I_{OL}	Low-level output current			2	mA
$t_{w(\text{clock})}$	Width of clock pulse	200			ns
$t_{su(H)}$	Setup time for high-level data	at A, B, C, or D		100	ns
		at word select		150	
$t_{su(L)}$	Setup time for low-level data	at A, B, C, or D		120	ns
		at word select		100	
T_A	Operating free-air temperature	-55	125		°C

electrical characteristics over recommended operating free-air temperature range (unless otherwise noted)

PARAMETER	TEST CONDITIONS†	SN54L98		UNIT	
		MIN	TYP ‡		MAX
V_{OH}	$V_{CC} = \text{MIN}$, $V_{IH} = 2 \text{ V}$, $V_{IL} = 0.7 \text{ V}$, $I_{OH} = -0.1 \text{ mA}$	2.4	3.3	V	
V_{OL}	$V_{CC} = \text{MIN}$, $V_{IH} = 2 \text{ V}$, $V_{IL} = 0.7 \text{ V}$, $I_{OL} = 2 \text{ mA}$		0.15	0.3	V
I_I	$V_{CC} = \text{MAX}$, $V_I = 5.5 \text{ V}$			0.1	mA
I_{IH}	$V_{CC} = \text{MAX}$, $V_I = 2.4 \text{ V}$			10	µA
I_{IL}	$V_{CC} = \text{MAX}$, $V_I = 0.3 \text{ V}$			-0.18	mA
$I_{OS} §$	$V_{CC} = \text{MAX}$	-3		-15	mA
I_{CC}	$V_{CC} = \text{MAX}$, See Note 3		5	9	mA

† For conditions shown as MIN or MAX, use the appropriate value specified under recommended operating conditions.

‡ All typical values are at $V_{CC} = 5 \text{ V}$, $T_A = 25^\circ\text{C}$.

§ Not more than one output should be shorted at a time.

NOTE 3: I_{CC} is measured with all inputs grounded and all outputs open.

switching characteristics, $V_{CC} = 5 \text{ V}$, $T_A = 25^\circ\text{C}$ (see note 4)

PARAMETER	FROM (INPUT)	TO (OUTPUT)	TEST CONDITIONS	MIN	TYP	MAX	UNIT
f_{max}	Any	Any	$R_L = 4 \text{ k}\Omega$, $C_L = 50 \text{ pF}$	3	5		MHz
t_{PLH}				115	200		ns
t_{PHL}				125	200		ns

NOTE 4: See General Information Section for load circuits and voltage waveforms.

3

TTL DEVICES

