

USB 3.0 A/M 9Pin
INS:Blue(PT 300C)

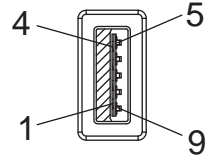

P1

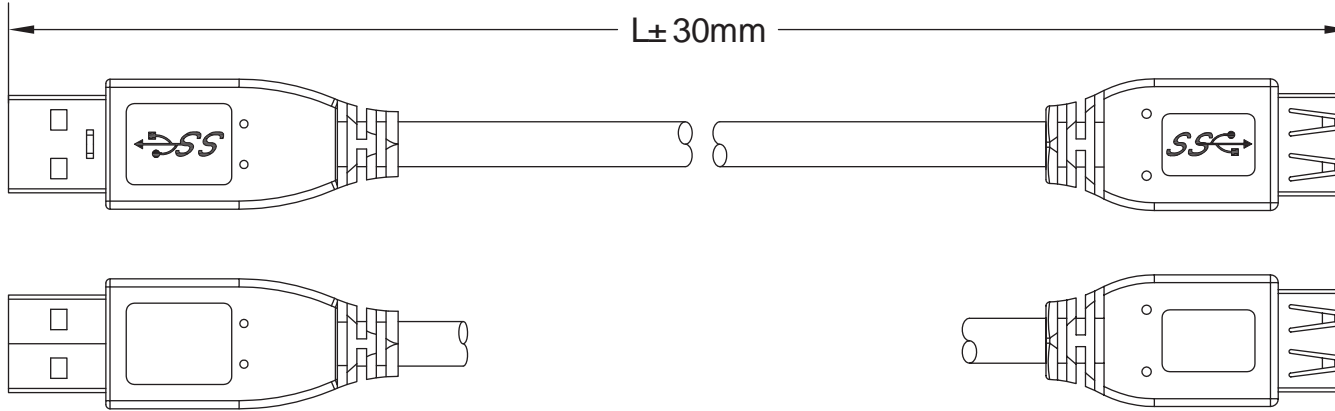

USB 3.0 A/F 9Pin
INS:Blue(PT 300C)

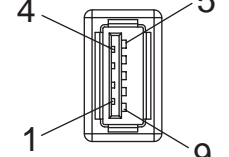

P2

Material:

- Cable: UL-2725 [# 28(7/0.1 27 T.C)* 1P INS:Foam-PE+ D.W (7/0.127 T.C)+ AL/MY+ Hot-melt-Mylar]* 2C+ # 28(7/0.127 T.C)* 1P INS:Polyolefin + # 28(7/0.127 T.C)* 2C INS:Polyolefin + AL/MY + B.D(85%)
 - PVC Jacket
 - OD: 5.2±0.15MM
 - Color: Black
- P1 Connector: USB 3.0 A Type Male 9 Pin
 - Contact: 30μ”
 - Shell: Ni-Plated
- P2 Connector: USB 3.0 A Type Female 9 Pin
 - Contact: 30μ”
 - Shell: Ni-Plated
- Hood: Molded Type, PVC 45P (Black)

Electrical:

- 100% Open short & mis wire test
- Contact Resistance: 3Ω Max.
- Insulation Resistance: 10MΩ Min.
- Hi-Pot 300V DC

P1	WIRING MAP	P2
1	RED	1
2	WHITE	2
3	GREEN	3
4	BLACK	4
5	BLUE	5
6	YELLOW	6
7	DRAIN WIRE	7
8	PURPLE	8
9	ORANGE	9
SHELL	BRAID	SHELL

Order Code: AK669/3-x-R

Order lengths in meter: 2,3,5

Unit: mm



Scale	1:1					Date	Name	Title USB 3.0 Extension cable 9 pin, black
TOLERANCE					Drawn	29.08.11	Chappell	
X.X	±0.40				Approved	26.02.13	Groll	ASSMANN WSW-No. AK669/3-x-R
X.XX	±0.25							Drawing-No.
X.XXX	±0.15							rev01
DIM	TOL							
X.°	±3°							
X.X°	±X°	①	Update	26.02.13	Wilson			Replace
Angle	TOL	Id.	Modification	Date	Name			Sheet 1/1



1840 W. Drake Drive, Suite 101 • Tempe, AZ 85283
Toll Free: 1-877-277-6266 • Email: info@assmann.us