

PCB Layout Component Side Shown

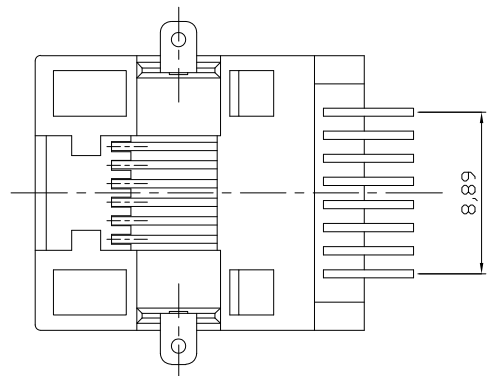

- NOTES:**
- Mechanical:**
- Housing material : PA9T UL94V-0 , Color: Black
 - Contact material: Phosphor Bronze t=0,35mm
 - Contact plating: Contact area---6u" Gold plating
Tails---Tin plated all over 50u" Nickel
 - Operating Life: 750 Cycles min.
 - PCB Retention Post-solder: 10 LBS min.
- Electrical:**
- Voltage Rating: 125VAC.
 - Current Rating: 1.5AMP.
 - Contact Resistance: 35mΩ max.
 - Insulation Resistance: 1000MΩ min. @ 500 VDC
 - Dielectric Strength: 1000 VAC 60Hz, 1 min.
- Environmental:**
- Storage: -40°C To +85°C
 - Operation: -40°C~+85°C
 - IR Reflow Soldering Temp.: 255°C~265°C(5~10S)

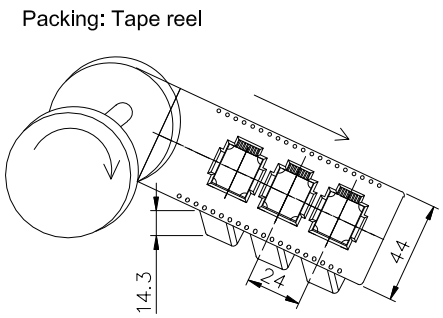

② Qty: 150pcs per reel

RoHS compliant
Unit:mm



File No.: E345352

Scale	Free					Date	Name	Customer-No.
TOLERANCE						Drawn	15.07.2009	Dean
X.X	±0.20					Approved	27.05.2013	Amy
X.XX	±0.15							
X.XXX	±0.10	③	Update	27.05.2013	Amy			
DIM	TOL	②	Changed the packing quantity	29.10.2010	Rate			
		①	Drawn	15.07.2009	Dean			
Angle	±5°	Id.	Modification	Date	Name			



Customer-No.	
ASSMANN WSW-No. A-20042-LP/SMT-A	
Drawing-No.	rev03
ASS 1050C CO	SHEET
Replace	