

**NOTES:**

**MATERIAL**

- 1. Insulator Material: PBT+30%G.F., (UL94V-0), Grey
- 2. Contact Material : Brass
- 3. Contact Plating : 1u" Au selective Over Ni

**ELECTRICAL**

- 1. Current Rating : 3.0 AMP
- 2. Withstand Voltage : 1000V AC/minute
- 3. Contact Resistance : 20mΩ max
- 4. Insulation Resistance: 1000MΩ min

**ENVIRONMENTAL**

- 1. Operation Temperature: -40°C to +105°C
- 2. Packing : Tray
- 3. 10P~18P with slot "M" without slot "N"
- 20P-64P with slot "M" and "N"

**Ordering Information**

**AWH xxG-E2x2-IDC**

No. of Contacts :  
10, 14, 16, 20, 26,  
30, 34, 40, 50, 60, 64

Latch Type  
0 -without latch  
2 -with short latches  
3 -with long latches

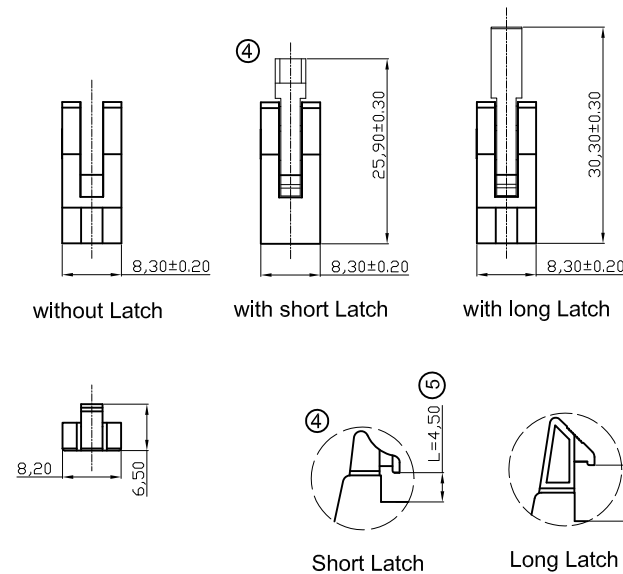

**RoHS compliant**  
Unit: mm



Scale	Free	⑥	Add UL file no.	12.12.2013	Amy		Date	Name	Customer-No.
TOLERANCE		⑤	Update	03.04.2013	Winnie	Drawn	29.05.2006	Hellwig	ASSMANN WSW-No. <b>AWH xxG-E2x2-IDC</b>
X.X	±0.40	④	Correct drawing of short latch	05.05.2010	Dean	Approved	12.12.2013	Amy	
X.XX	±0.25	③	Modify dimension from 7.65 to 7.85	03.11.2009	Dean				
X.XXX	±0.15	③	Modify dimension from 7.65 to 7.85	03.11.2009	Dean				Drawing-No.
ANGLE	±3°	②	Increase right view Modification dimensions	16.02.2009	Dean				ASS 0532 CO
		①	Drawn	29.05.2006	Hellwig				Replace
DIM	TOL	Id.	Modification	Date	Name				Sheet

1

2

3

4

5

6

7