

P.C.B LAYOUT

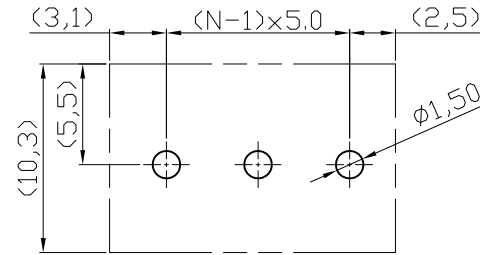

Material

Terminal body
(metal housing):Brass(CuZn)
Terminal screw: Steel Zinc plating "-" slot type
Contacts: Brass
Surface of solder tail: Tin plated
Insulator (housing): Thermoplastic (UL94V-0),Green

Electrical UL

Voltage rating: 300VAC
Current rating: 10A
Wire range:
Solid wire(AWG): 12-22
Stranded wire(AWG): 12-22
Torque(Lb-In): 3.5
Screw: M2.5
Wire strip length: 6-7mm
Withstanding Voltage: 1.6KV
Operating temperature: -40°C to +115°C
Soldering temperature: 250°C±10°C/5 Sec
Safety Approval:

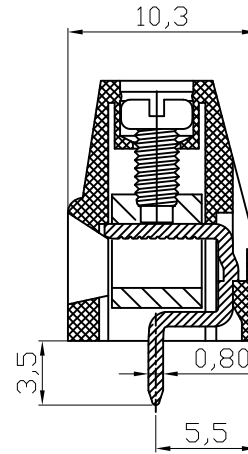
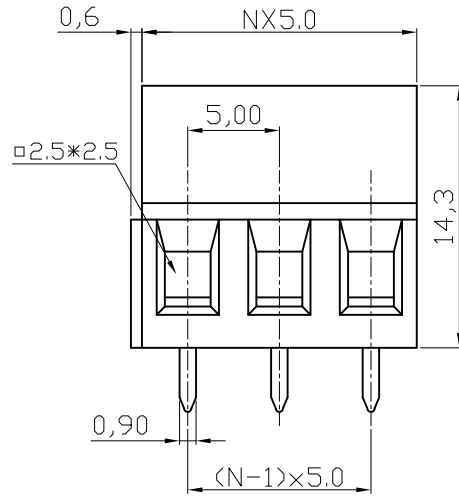

N=Number of contacts

RoHS compliant

Scale	1:1						Date	Name	Customer-No.
TOLERANCE						Drawn	29.07.2009	Dean	ASSMANN WSW-No. A-TB500-TIxx
X.	±0.50					Approved	29.07.2009	Hellwig	
X.X	±0.30								
X.XX	±0.10								
DIM	TOL								Drawing-No.
X.°	±1°								ASS 3594 CO rev01
X.X°	±X°	①	Drawn	29.07.2009	Dean			Replace	
Angle	TOL	Id.	Modification	Date	Name			Sheet	

