

P.C.B LAYOUT

**Material**

Terminal body  
 (metal housing): Brass(CuZn)  
 Terminal screw: Steel Zinc plating "-" slot type  
 Contacts: Brass  
 Surface of solder tail: Tin plated  
 Insulator (housing): Thermoplastic (UL94V-0),Green

**Electrical**

Voltage rating: 300VAC  
 Current rating: 20A  
 Solid wire(AWG): 12-30  
 Stranded wire(AWG): 12-30  
 Torque(Lb-In): 3.5  
 Screw: M3  
 Wire strip length: 6-7mm  
 Withstanding Voltage: 1.6KV  
 Operating temperature: -40°C to +115°C  
 Soldering temperature: 250°C±10°C/5 Sec  
 Safety Approval: us

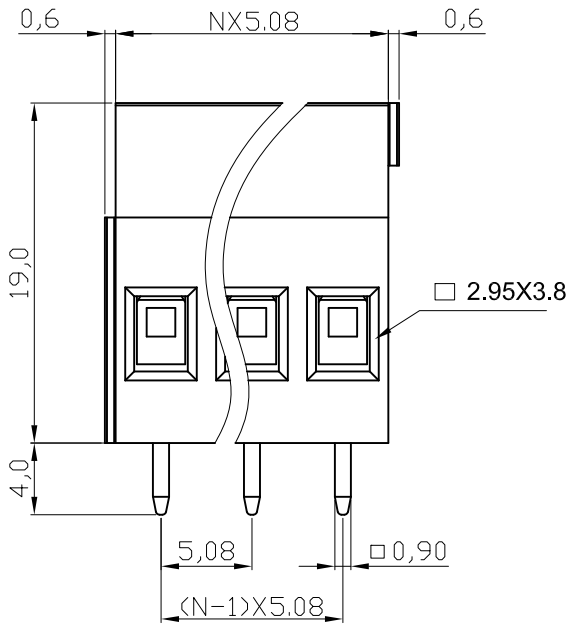

N=Number of contacts

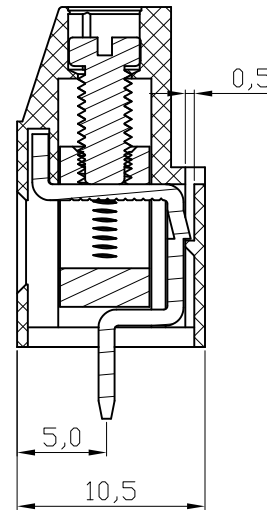

**RoHS compliant**

Scale	1:1						Date	Name	Customer-No.
TOLERANCE						Drawn	29.07.2009	Dean	
X.	±0.50					Approved	29.07.2009	Hellwig	ASSMANN WSW-No. <b>A-TB508-VJxxH</b>
X.X	±0.30								Drawing-No.
X.XX	±0.10								<b>ASS 3595 CO</b>
DIM	TOL								rev01
X.°	±1°								
X.X°	±X°	①	Drawn	29.07.2009	Dean			Replace	Sheet
Angle	TOL	Id.	Modification	Date	Name				