

REV.	DATE	ECR NO.	DESCRIPTION
NC	02/03/09	-	INITIAL RELEASE

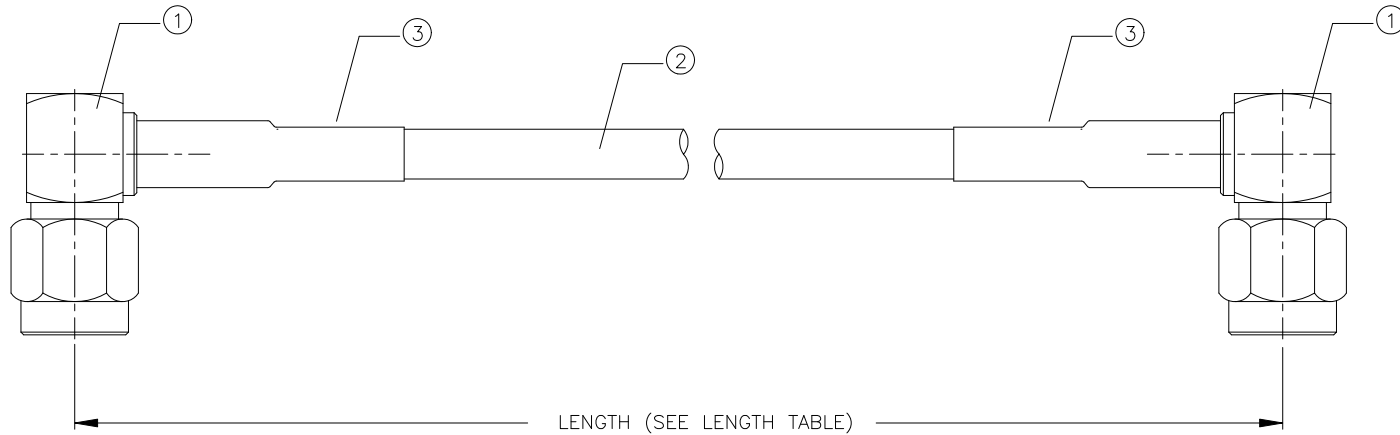

LENGTH TABLE	
PART NUMBER	LENGTH (IN.)
135104-01-06.00	6.00
135104-01-12.00	12.00
135104-01-24.00	24.00
135104-01-36.00	36.00

NOTE:

1. PERFORM CONTINUITY AND HI-POT TESTING.
2. PACKAGED INDIVIDUALLY IN HEAT SEALED POLY BAG.

4			
3	009-954-341	HEAT SHRINK TUBING, BLACK, 3/16" DIAMETER	A/R FT
2	009-881-205	COAXIAL CABLE, RG316/U	A/R FT
1	132123	CONNECTOR, SMA R/A PLUG, GOLD	2
	PN	DESCRIPTION	QTY

UNLESS OTHERWISE SPECIFIED DIMENSIONS ARE IN MILLIMETERS. DIMENSIONS IN [] ARE IN INCHES AND FOR CUSTOMER REFERENCE ONLY.

UNLESS OTHERWISE SPECIFIED TOLERANCES FOR MILLIMETERS ARE:
0.5 - 8mm ± 0.20mm
8 - 30mm ± 0.40mm
30 - 120mm ± 0.50mm

UNLESS OTHERWISE SPECIFIED TOLERANCES FOR INCHES ARE:
.020 - .315 = ± 0.007"
.315 - 1.180 = ± 0.015"
1.180 - 4.724 = ± 0.020"

DO NOT SCALE DRAWING

APPROVALS	DATE
DRAWN G.R.S.	02/03/09
CHECKED	
ISSUED	
SHEET 1 OF 1	
CAD FILE	C:/135/135104-01-XX.XX.DWG

Amphenol Connex

PART DESCRIPTION

SMA R/A PLUG TO SMA R/A PLUG
RG316

PART NO.

135104-01-XX.XX

DWG. NO.

135104-01-XX.XX.DWG

REV. NC

SIZE A

SCALE NA