

REV.	DATE	ECR NO.	DESCRIPTION
NC	10/09/08	-	INITIAL RELEASE

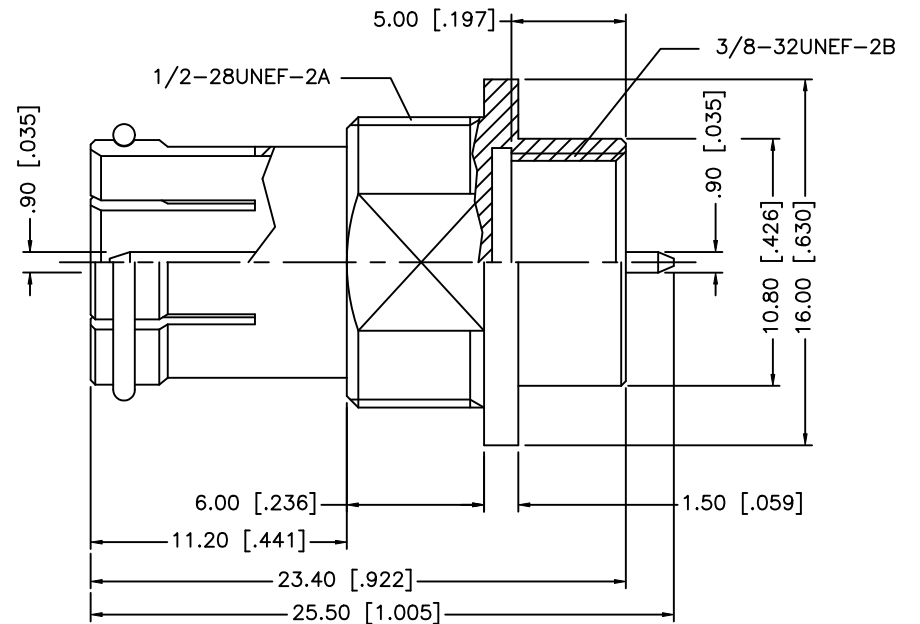
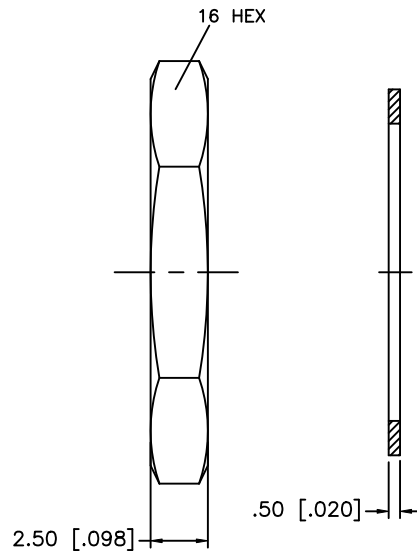
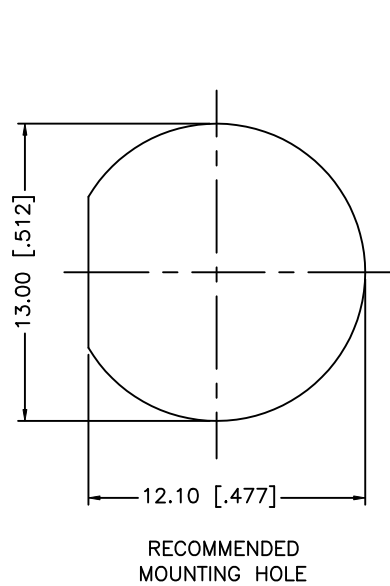

NOTE:
1. MAX. PANEL THICKNESS OF 3mm [.118]

8				
7				
6				
5	HEX NUT	BRASS	NICKEL	1
4	LOCK WASHER	BRASS	NICKEL	1
3	CONTACT PIN	BRASS	NICKEL	1
2	INSULATOR	PTFE	NATURAL	1
1	BODY	BRASS	NICKEL	1
	DESCRIPTION	MATERIAL	FINISH	QTY

UNLESS OTHERWISE SPECIFIED DIMENSIONS ARE IN MILLIMETERS. DIMENSIONS IN [] ARE IN INCHES AND FOR CUSTOMER REFERENCE ONLY.

UNLESS OTHERWISE SPECIFIED TOLERANCES FOR MILLIMETERS ARE:
0.5 - 8mm ± 0.20mm
8 - 30mm ± 0.40mm
30 - 120mm ± 0.50mm

UNLESS OTHERWISE SPECIFIED TOLERANCES FOR INCHES ARE:
.020 - .315 = ± 0.007"
.315 - 1.180 = ± 0.015"
1.180 - 4.724 = ± 0.020"

DO NOT SCALE DRAWING

APPROVALS		DATE
DRAWN	GRS	10/09/08
CHECKED		
ISSUED		
SHEET	1 OF 1	
CAD FILE	C:/222/222206.DWG	

Amphenol Connex

PART DESCRIPTION
F PLUG TO F PLUG BULKHEAD ADAPTER

PART NO. **222206**

DWG. NO.	222206.DWG	REV.	NC	SIZE	A	SCALE	NA
----------	------------	------	----	------	---	-------	----