

REV.	DATE	ECR NO.	DESCRIPTION
NC	02/24/02	-	INITIAL RELEASE
A	03/26/09	100089	UPDATE DRAWING FORMAT, ADD TOLERANCES TO MOUNTING HOLE DIMS.

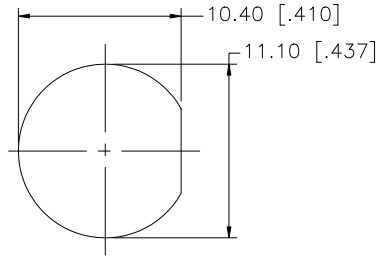

RECOMMENDED MOUNTING HOLE

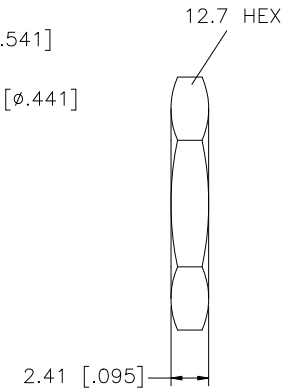
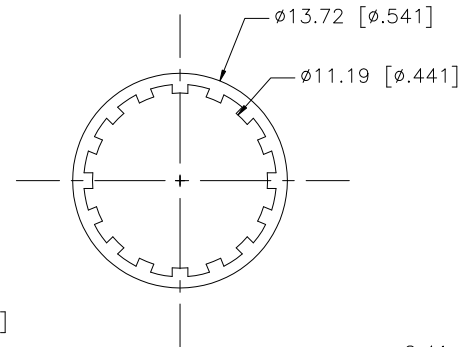
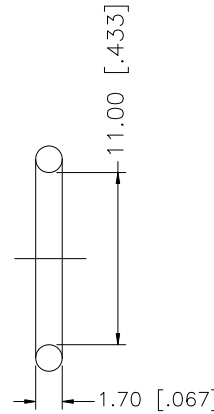
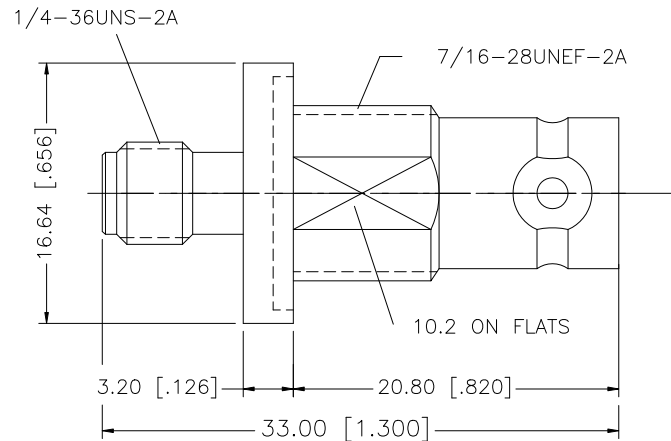

NOTE:  
1. MAX. PANEL THICKNESS = 6.6mm

8			
7			
6	HEX NUT	BRASS	NICKEL 1
5	LOCK WASHER	PHOS. BRONZE	NICKEL 1
4	GASKET	SILICONE	RED 1
3	CONTACT PIN	BER. COPPER	GOLD 1
2	INSULATOR	PTFE	NATURAL 1
1	BODY	BRASS	NICKEL 1
DESCRIPTION	MATERIAL	FINISH	QTY

UNLESS OTHERWISE SPECIFIED DIMENSIONS ARE IN MILLIMETERS. DIMENSIONS IN [ ] ARE IN INCHES AND FOR CUSTOMER REFERENCE ONLY.

UNLESS OTHERWISE SPECIFIED TOLERANCES FOR MILLIMETERS ARE:  
0.5 - 8mm ± 0.20mm  
8 - 30mm ± 0.40mm  
30 - 120mm ± 0.50mm

UNLESS OTHERWISE SPECIFIED TOLERANCES FOR INCHES ARE:  
.020 - .315 ± 0.007"  
.315 - 1.180 ± 0.015"  
1.180 - 4.724 ± 0.020"

DO NOT SCALE DRAWING

APPROVALS	DATE
DRAWN GRS	03/26/09
CHECKED	
ISSUED	
SHEET 1 OF 1	
CAD FILE	C:/242/242181.DWG

# Amphenol Connex

PART DESCRIPTION

SMA JACK TO BNC BULKHEAD JACK ADAPTER

PART NO.

242181

DWG. NO.

242181.DWG

REV. NC

SIZE A

SCALE NA