

REV.	DATE	ECR NO.	DESCRIPTION
NC	09/09/10	XXXXXX	INITIAL RELEASE

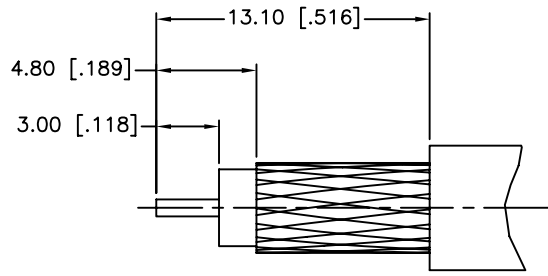

RECOMMENDED
CABLE STRIPPING DIM'S

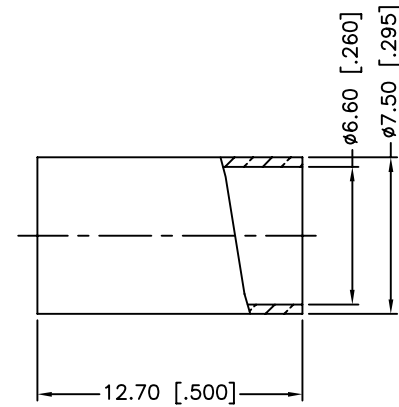
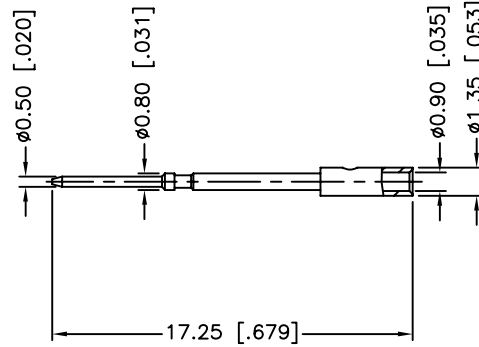
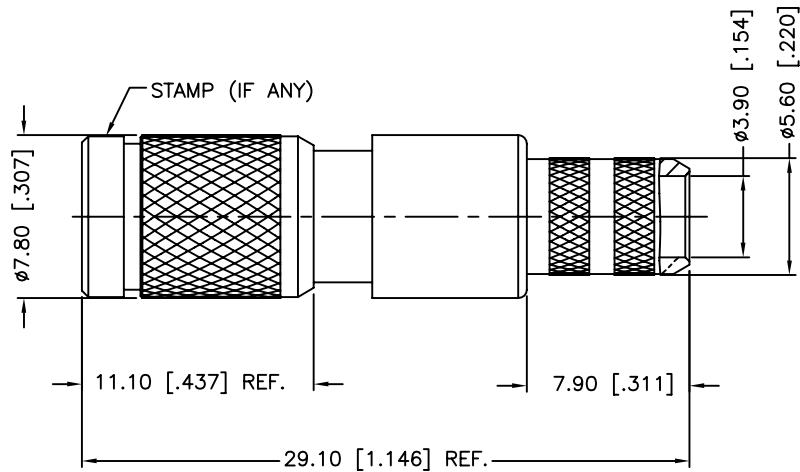

1. FREQUENCY RANGE: DC - 3 GHz
2. VSWR (RETURN LOSS): 1.15, MAX.
3. CRIMPED FERRULE
HEX CRIMP SIZE .255"
4. CRIMPED CONTACT PIN
HEX CRIMP SIZE .043"

8	FERRULE	BRASS	NICKEL	1
7	CONTACT PIN	BRASS	GOLD	1
6	BARREL	BRASS	NICKEL	1
5	OUT CONTACT	BER. COPPER	GOLD	1
4	INSULATOR	PTFE	NATURAL	1
3	SPRING	SUS 301H	PASSIVATED	1
2	BODY	BRASS	NICKEL	1
1	SHELL	BRASS	NICKEL	1
	DESCRIPTION	MATERIAL	FINISH	QTY

UNLESS OTHERWISE SPECIFIED DIMENSIONS ARE IN MILLIMETERS. DIMENSIONS IN [] ARE IN INCHES AND FOR CUSTOMER REFERENCE ONLY.

UNLESS OTHERWISE SPECIFIED TOLERANCES FOR MILLIMETERS ARE:
0.5 - 8mm ± 0.20mm
8 - 30mm ± 0.40mm
30 - 120mm ± 0.50mm

UNLESS OTHERWISE SPECIFIED TOLERANCES FOR INCHES ARE:
.020 - .315 ± 0.007"
.315 - 1.180 ± 0.015"
1.180 - 4.724 ± 0.020"

DO NOT SCALE DRAWING

APPROVALS	DATE
DRAWN M.ZHANG	09/09/10
CHECKED	
ISSUED	
SHEET 1 OF 1	
CAD FILE C:/CONNEX/282135-75.DWG	

Amphenol Connex

PART DESCRIPTION	1.0/2.3 PUSH-PULL CRIMP PLUG (FOR BELDEN 1505A CABLE)		
PART NO.	282135-75		
DWG. NO.	282135-75.DWG	REV.	NC
SIZE	A	SCALE	NA