

REV.	DATE	ECR NO.	DESCRIPTION
NC	09/09/10	XXXXXX	INITIAL RELEASE

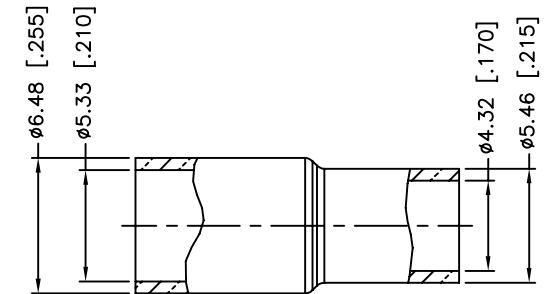
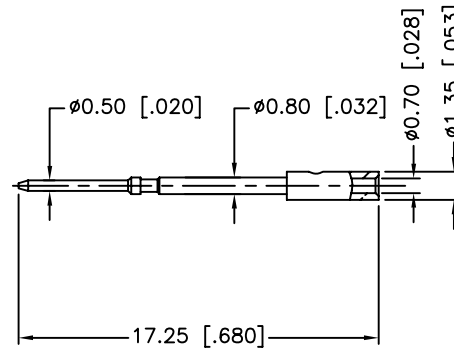
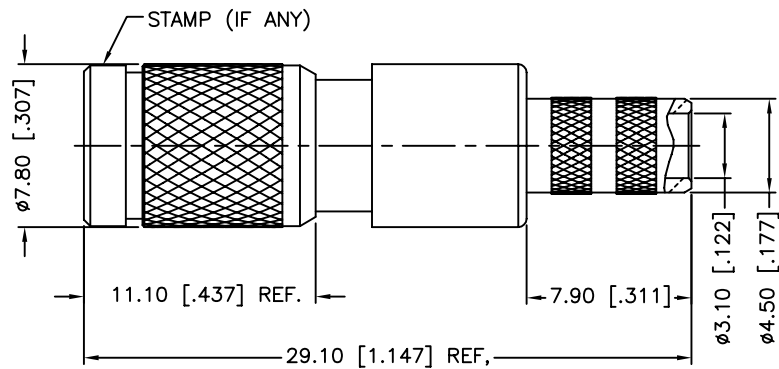
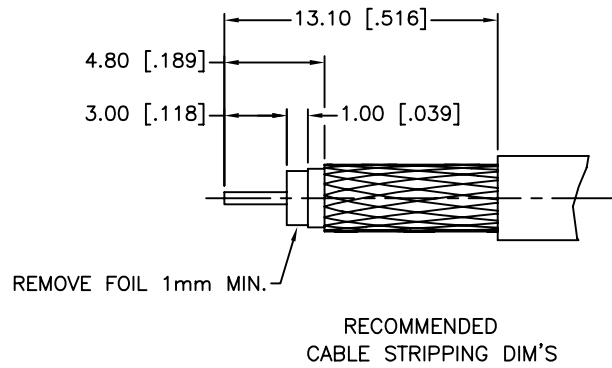

1. FREQUENCY RANGE: DC - 3 GHz
2. VSWR (RETURN LOSS): 1.15, MAX.
3. CRIMPED FERRULE  
HEX CRIMP SIZE .213"
4. CRIMPED CONTACT PIN  
HEX CRIMP SIZE .043"

8	FERRULE	COPPER	NICKEL	1
7	CONTACT PIN	BRASS	GOLD	1
6	BARREL	BRASS	NICKEL	1
5	OUT CONTACT	BER. COPPER	GOLD	1
4	INSULATOR	PTFE	NATURAL	1
3	SPRING	SUS 301H	PASSIVATED	1
2	BODY	BRASS	NICKEL	1
1	SHELL	BRASS	NICKEL	1
	DESCRIPTION	MATERIAL	FINISH	QTY

UNLESS OTHERWISE SPECIFIED DIMENSIONS ARE IN MILLIMETERS. DIMENSIONS IN [ ] ARE IN INCHES AND FOR CUSTOMER REFERENCE ONLY.

UNLESS OTHERWISE SPECIFIED TOLERANCES FOR MILLIMETERS ARE:  
0.5 - 8mm ± 0.20mm  
8 - 30mm ± 0.40mm  
30 - 120mm ± 0.50mm

UNLESS OTHERWISE SPECIFIED TOLERANCES FOR INCHES ARE:  
.020 - .315 ± 0.007"  
.315 - 1.180 ± 0.015"  
1.180 - 4.724 ± 0.020"

DO NOT SCALE DRAWING

APPROVALS	DATE
DRAWN M.ZHANG	09/09/10
CHECKED	
ISSUED	
SHEET 1 OF 1	
CAD FILE C:/CONNEX/282125-75.DWG	

# Amphenol Connex

PART DESCRIPTION	1.0/2.3 PUSH-PULL CRIMP PLUG (FOR BELDEN 1855A CABLE)		
PART NO.	282138-75		
DWG. NO.	282138-75.DWG	REV.	NC
SIZE	A	SCALE	NA