

REV.	DATE	DESCRIPTION
A	12/29/00	REVISE PLATING TO SILVER
B	12/06/06	UPDATE DRAWING FORMAT
C	09/20/07	MODIFY BODY TO HEX COUPLING NUT

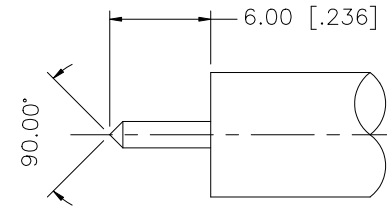
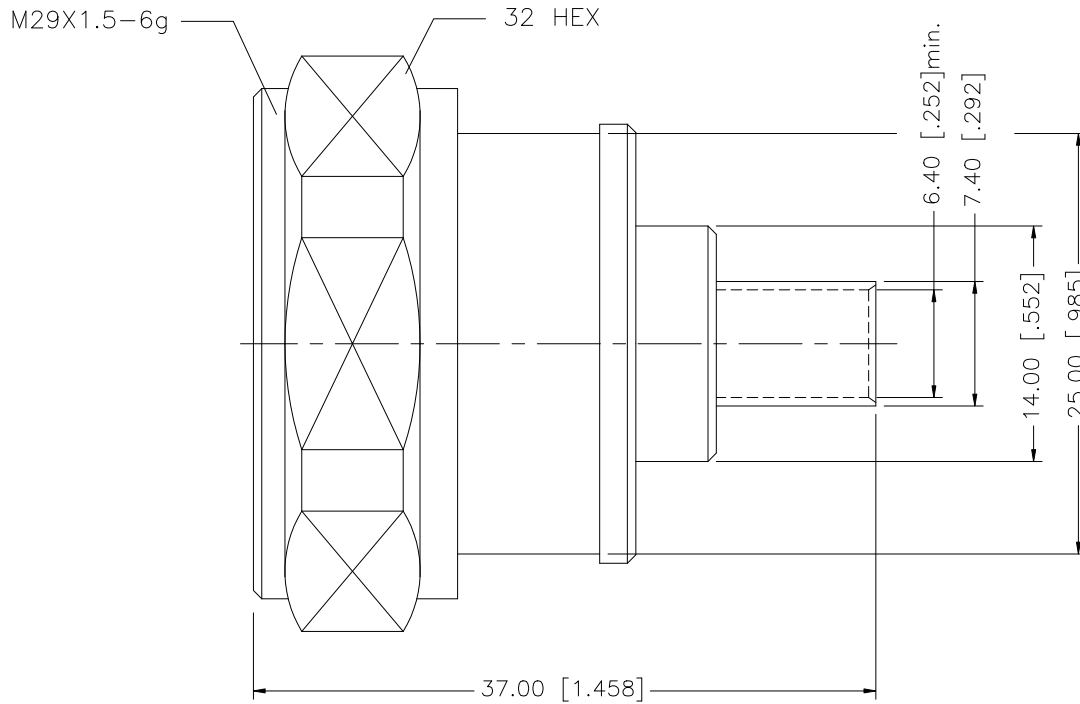

RECOMMENDED CABLE STRIPPING DIM'S

8					<small>UNLESS OTHERWISE SPECIFIED DIMENSIONS ARE IN MILLIMETERS. DIMENSIONS IN [] ARE IN INCHES AND FOR CUSTOMER REFERENCE ONLY.</small> <small>UNLESS OTHERWISE SPECIFIED TOLERANCES FOR MILLIMETERS ARE:</small> 0.5 - 8mm ± 0.20mm 8 - 30mm ± 0.40mm 30 - 120mm ± 0.50mm <small>UNLESS OTHERWISE SPECIFIED TOLERANCES FOR INCHES ARE:</small> .020 - .315 = ± 0.007" .315 - 1.180 = ± 0.015" 1.180 - 4.724 = ± 0.020"	APPROVALS	DATE	<h1 style="color: blue;">Amphenol Connex</h1>					
7				DRAWN		G.R.S.	09/20/07						
6				CHECKED				PART DESCRIPTION <h2 style="text-align: center;">7/16 PLUG - .250" SEMI RIGID CABLE</h2>					
5				ISSUED									
4							PART NO. <h2 style="text-align: center;">272110</h2>						
3	CONTACT PIN	BER. COPPER	SILVER	1	SHEET	1 OF 1							
2	INSULATOR	TEFLON	NATURAL	1	DWG. NO. 272110.DWG			REV.	C	SIZE	A	SCALE	NA
1	BODY	BRASS	NEXCOTE	1				CAD FILE C:/272/272110.DWG					
	DESCRIPTION	MATERIAL	FINISH	QTY	DO NOT SCALE DRAWING								