

REV.	DATE	DESCRIPTION
A	10/13/09	RELEASE TO MFG.
B	01/22/10	ADDED PN:112740-12 THROUGH 112740-17 AND BOARD THICKNESS OPTIONS
C	02/04/10	THREAD LENGTH AND MAX. PANEL THICKNESS DIMENSION UPDATED

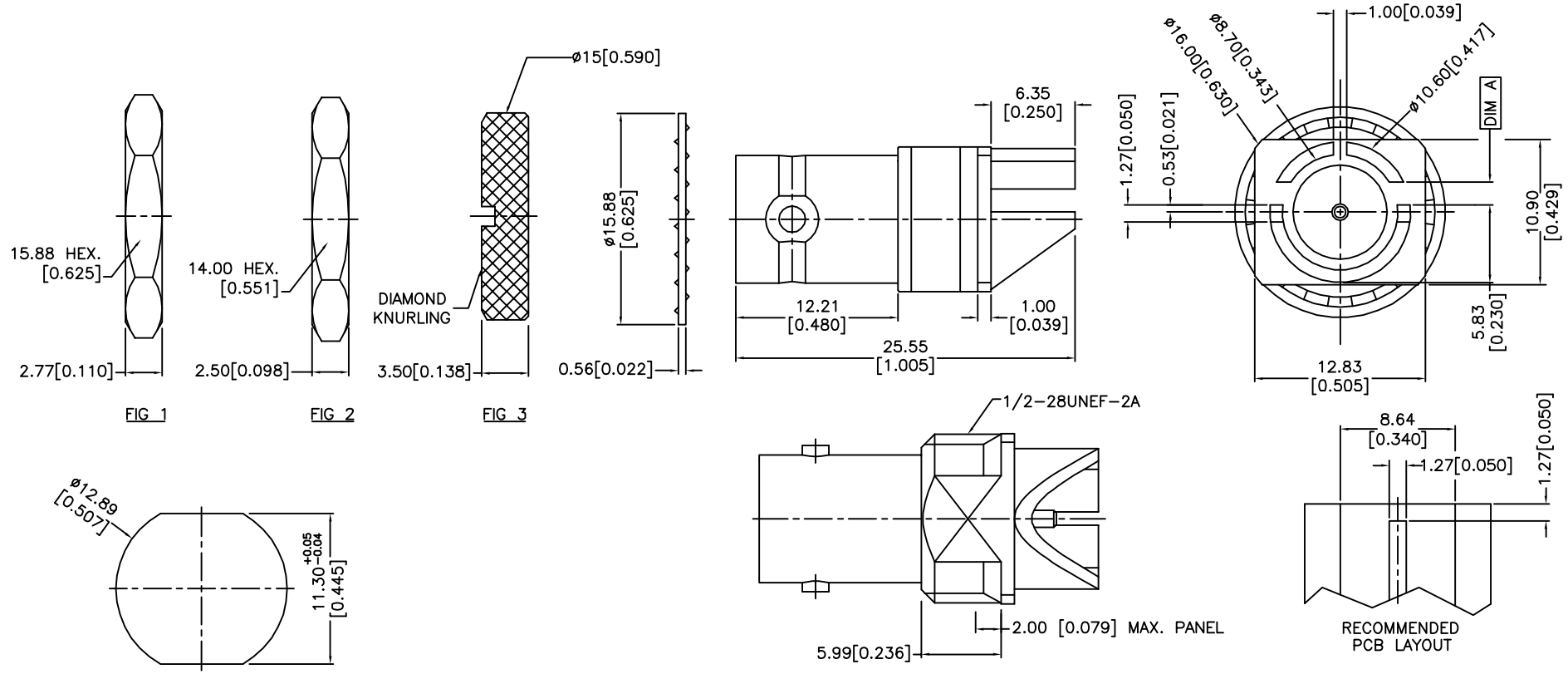

RECOMMENDED MOUNTING HOLE DIMENSIONS

NOTES:
 BNC RECPY SHIPS WITH ONLY ONE KIND OF THREADED NUT,
 SEE TABLE FOR DETAIL

NO	PART NUMBER	RECOMMENDED PCB THICKNESS	DIM A	INCLUDED NUT
6	112740-17	0.084"	.087+0.003/-0.0	FIG 3
5	112740-16	0.084"	.087+0.003/-0.0	FIG 2
4	112740-15	0.084"	.087+0.003/-0.0	FIG 1
3	112740-14	0.062"	.069+/-0.002	FIG 3
2	112740-13	0.062"	.069+/-0.002	FIG 2
1	112740-12	0.062"	.069+/-0.002	FIG 1

NO	DESCRIPTION	MATERIAL	FINISH	QTY
6	NUT	BRASS	NICKEL	1
5	LOCK WASHER	BRASS	NICKEL	1
4	HOUSING	BRASS	GOLD	1
3	CONTACT PIN	PHOSPHOR BRONZE	GOLD	1
2	INSULATOR	TEFLON	NATURAL	1
1	BODY	BRASS	GOLD	1

UNLESS OTHERWISE SPECIFIED DIMENSIONS ARE IN MILLIMETERS. DIMENSIONS IN [] ARE IN INCHES AND FOR CUSTOMER REFERENCE ONLY.

UNLESS OTHERWISE SPECIFIED TOLERANCES FOR MILLIMETERS ARE:
 0.5 - 8mm ± 0.20mm
 8 - 30mm ± 0.40mm
 30 - 120mm ± 0.50mm

UNLESS OTHERWISE SPECIFIED TOLERANCES FOR INCHES ARE:
 .020 - .315 = ± 0.007"
 .315 - 1.180 = ± 0.015"
 1.180 - 4.724 = ± 0.020"

DO NOT SCALE DRAWING

APPROVALS	DATE
DRAWN BALAJI M	01/22/10
CHECKED	
ISSUED	
SHEET 1 OF 1	
CAD FILE	C:\112\112740-XX.DWG

AMPHENOL CONNEX

PART DESCRIPTION
BNC END LAUNCH RECEPT.JACK,75 OHMS

PART NO.
112740-XX

DWG. NO.	112740-XX.DWG	REV.	C	SIZE	A	SCALE	NA
----------	---------------	------	---	------	---	-------	----