

REV.	DATE	ECR NO.	DESCRIPTION
A	02/10/10	XXXXXX	UPDATE DRAWING FORMAT

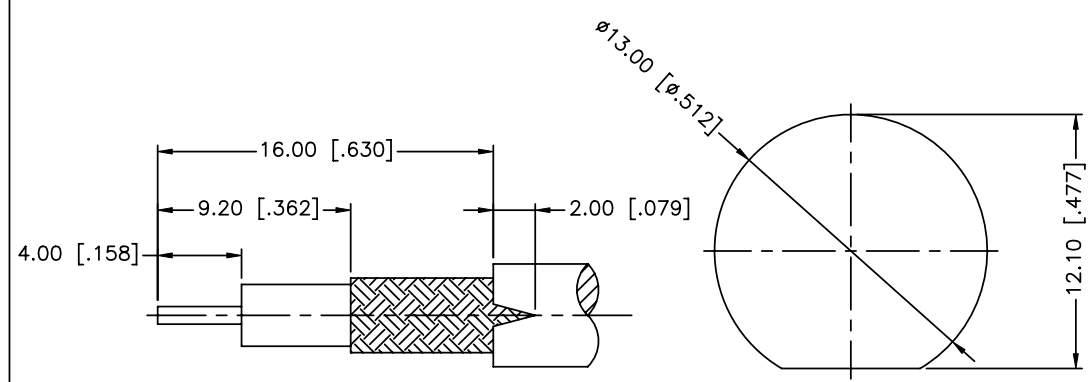

RECOMMENDED
CABLE STRIPPING DIM'S

RECOMMENDED
MOUNTING HOLE

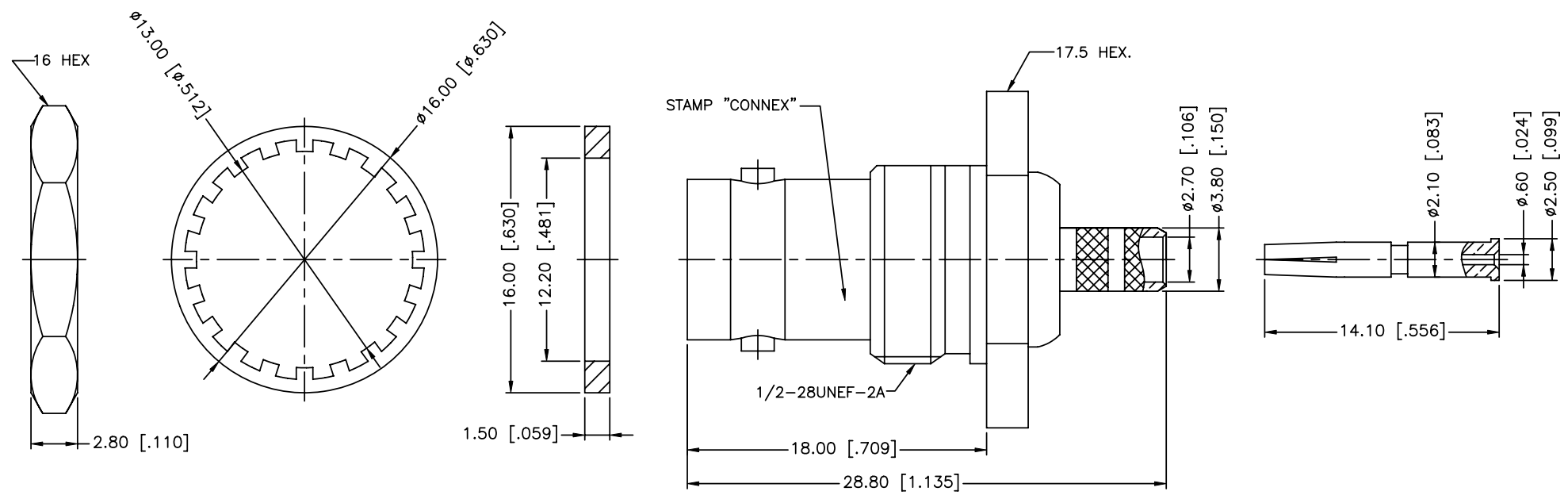
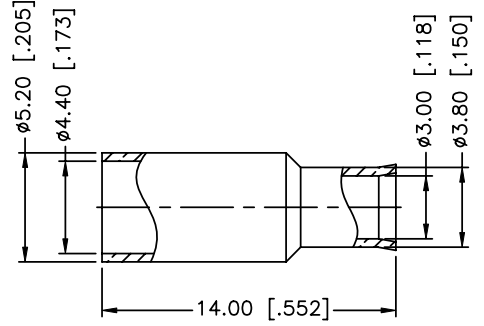

- NOTES:
1. CRIMPED FERRULE
HEX CRIMP SIZE .178"
 2. CRIMPED CONTACT PIN
HEX CRIMP SIZE .068"
 3. MAX. PANEL THICKNESS=3.5mm

DESCRIPTION	MATERIAL	FINISH	QTY
10 FERRULE	BRASS	NICKEL	1
9 SLEEVE	DELTRIN	NATURAL	1
8 CONTACT PIN	PHOSPHOR BRONZE	GOLD	1
7 HEX NUT	BRASS	NICKEL	1
6 LOCK WASHER	BRASS	NICKEL	1
5 GASKET	RUBBER	RED	1
4 BARREL	BRASS	NICKEL	1
3 INSULATOR	DELTRIN	NATURAL	1
2 BODY	BRASS	NICKEL	1
1 HOUSING	BRASS	NICKEL	1

UNLESS OTHERWISE SPECIFIED DIMENSIONS ARE IN MILLIMETERS. DIMENSIONS IN [] ARE IN INCHES AND FOR CUSTOMER REFERENCE ONLY.

UNLESS OTHERWISE SPECIFIED TOLERANCES FOR MILLIMETERS ARE:
0.5 - 8mm ± 0.20mm
8 - 30mm ± 0.40mm
30 - 120mm ± 0.50mm

UNLESS OTHERWISE SPECIFIED TOLERANCES FOR INCHES ARE:
.020 - .315 = ± 0.007"
.315 - 1.180 = ± 0.015"
1.180 - 4.724 = ± 0.020"

DO NOT SCALE DRAWING

APPROVALS	DATE
DRAWN TANGOR	02/10/10
CHECKED	
ISSUED	
SHEET 1 OF 1	
CAD FILE	
C:/CONNEX/112234.DWG	

Amphenol Connex

PART DESCRIPTION
BNC BULKHEAD CRIMP JACK
FOR RG 174, 316 AND 188/U CABLE

PART NO.
112234

DWG. NO. 112234.DWG	REV. A	SIZE A	SCALE NA
-------------------------------	------------------	------------------	--------------------