

RECOMMENDED  
CABLE STRIPPING DIM'S

REV.	DATE	ECR NO.	DESCRIPTION
A	11/20/97	-	ADD CENTER CONTACT
B	04/08/98	-	ADD LMR240 CABLE TO TITLE
C	12/12/06	-	UPDATE DRAWING FORMAT
D	04/01/08	-	REVISE INSULATOR TO PTFE
E	06/23/10	2062	ADD CRIMP DIMENSIONS AND CRIMP TOOL INFORMATION TO DRAWINGS

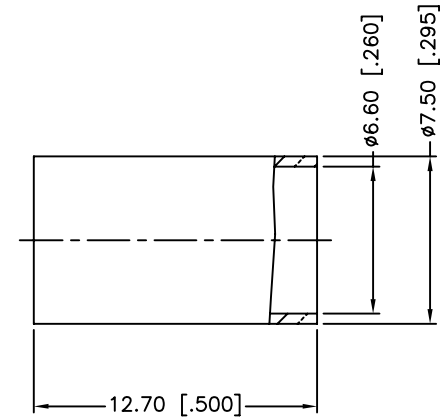
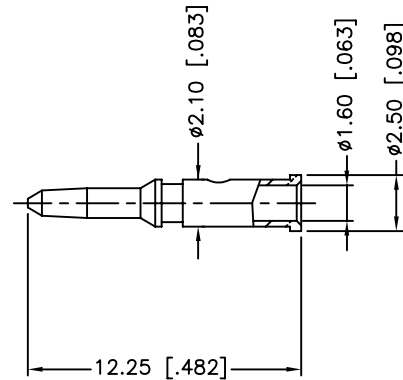
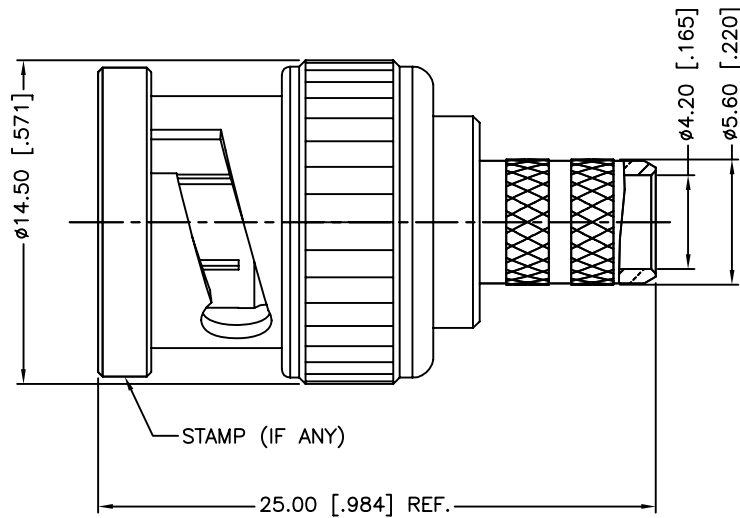

1. CRIMPED FERRULE  
HEX. CRIMP SIZE .255"
2. CRIMPED CONTACT PIN  
HEX. CRIMP SIZE .068"
3. CRIMP TOOL: A

9	FERRULE	BRASS	NICKEL	1
8	CONTACT PIN	BRASS	GOLD	1
7	WASHER	BRASS	NICKEL	1
6	SPRING	SK5	NICKEL	1
5	RETAINER RING	BRASS	NICKEL	1
4	GASKET	RUBBER	RED	1
3	INSULATOR	DELTRIN	NATURAL	1
2	BODY	BRASS	NICKEL	1
1	SHELL	BRASS	NICKEL	1
	DESCRIPTION	MATERIAL	FINISH	QTY

UNLESS OTHERWISE SPECIFIED DIMENSIONS ARE IN MILLIMETERS. DIMENSIONS IN [ ] ARE IN INCHES AND FOR CUSTOMER REFERENCE ONLY.

UNLESS OTHERWISE SPECIFIED TOLERANCES FOR MILLIMETERS ARE:  
0.5 - 8mm ± 0.20mm  
8 - 30mm ± 0.40mm  
30 - 120mm ± 0.50mm

UNLESS OTHERWISE SPECIFIED TOLERANCES FOR INCHES ARE:  
.020 - .315 = ± 0.007"  
.315 - 1.180 = ± 0.015"  
1.180 - 4.724 = ± 0.020"

DO NOT SCALE DRAWING

APPROVALS		DATE
DRAWN	M.ZHANG	06/23/10
CHECKED		
ISSUED		
SHEET	1 OF 1	
CAD FILE	C:/CONNEX/112533.DWG	

# Amphenol Connex

PART DESCRIPTION			
BNC CRIMP PLUG (FOR BELDEN RG-8/X LMR240 CABLE)			
PART NO. 112533			
DWG. NO.	112533.DWG	REV.	E
SIZE	A	SCALE	NA