

REV.	DATE	ECR NO.	DESCRIPTION
A	08/22/98	XXXXXX	ADD SLEEVE
B	04/23/02	XXXXXX	MODIFY CONTACT PIN AND BODY LENGTH
C	01/06/03	XXXXXX	UPDATE DRAWING FORMAT
D	10/11/13	2535	FACTORY DRAWING UPDATED

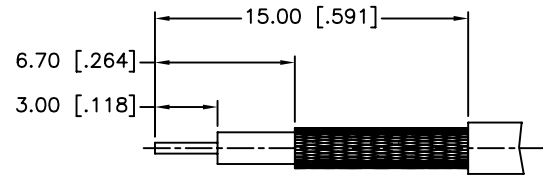

RECOMMENDED
CABLE STRIPPING DIM'S

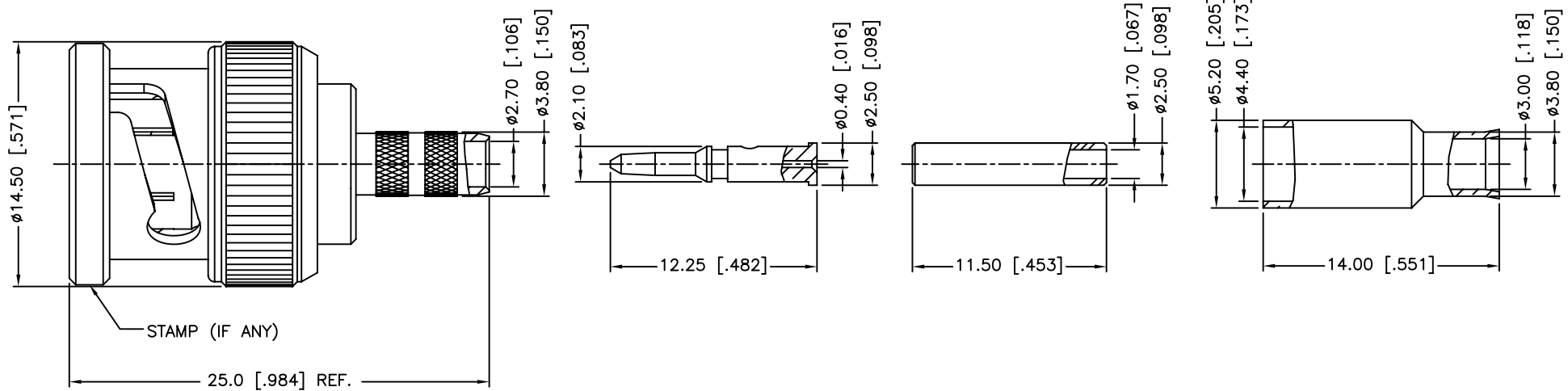

1. IMPEDANCE: 75 OHM
2. FREQUENCY RANGE: 0-2 GHZ
3. VSWR: 1.3 MAX.
4. DIELECTRIC WITHSTANDING VOLTAGE: 1500 VRMS, MIN.
5. DURABILITY: 500 CYCLES MIN.
6. TEMPERATURE RANGE: -40°C TO +85°C
7. CRIMPED FERRULE
HEX. CRIMP SIZE .178"
8. CRIMPED CONTACT PIN
HEX. CRIMP SIZE .068"

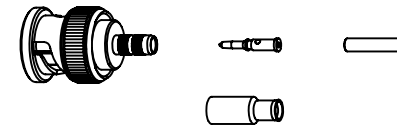

NO.	DESCRIPTION	MATERIAL	FINISH	QTY
10	FERRULE	BRASS	NICKEL	1
9	SLEEVE	DELTRIN	NATURAL	1
8	CONTACT PIN	BRASS	GOLD	1
7	WASHER	BRASS	NICKEL	1
6	SPRING	SK5	NICKEL	1
5	RETAINER RING	BRASS	NICKEL	1
4	GASKET	SILICONE RUBBER	RED	1
3	INSULATOR	DELTRIN	NATURAL	1
2	BODY	BRASS	NICKEL	1
1	SHELL	ZINC DIECAST	NICKEL	1
	DESCRIPTION	MATERIAL	FINISH	QTY

UNLESS OTHERWISE SPECIFIED DIMENSIONS ARE IN MILLIMETERS. DIMENSIONS IN [] ARE IN INCHES AND FOR CUSTOMER REFERENCE ONLY.
UNLESS OTHERWISE SPECIFIED
TOLERANCES FOR MILLIMETERS ARE:
<0.5 ± 0.05mm
0.5 - 6mm ± 0.10mm
6 - 30mm ± 0.20mm
30 - 120mm ± 0.30mm
ANGLES ± 1°
UNLESS OTHERWISE SPECIFIED
TOLERANCES FOR INCHES ARE:
<.020 ± 0.002"
.020 - .236 = ± 0.004"
.236 - 1.180 = ± 0.007"
1.180 - 4.724 = ± 0.012"
ANGLES ± 1°

DO NOT SCALE DRAWING

APPROVALS		DATE
DRAWN	M.ZHANG	10/11/13
CHECKED		
ISSUED		
SHEET	1 OF 1	
CAD FILE	C:/CONNEX/112135.DWG	

Amphenol Connex			
PART DESCRIPTION BNC CRIMP PLUG-75 OHMS (FOR RG-179/U,187/U CABLE)			
PART NO. 112135			
DWG. NO.	112135.DWG	REV.	D
SIZE	A	SCALE	NA