

REV.	DATE	DESCRIPTION
A	04/05/03	UPDATE DRAWING FORMAT
B	07/19/07	REVISE BARREL AND FERRULE DIMENSIONS

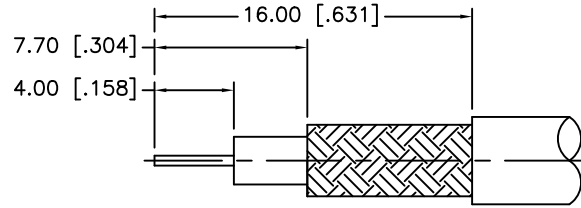

RECOMMENDED CABLE STRIPPING DIM'S

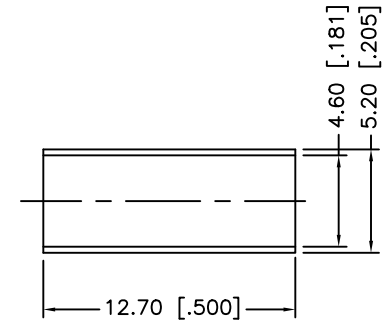
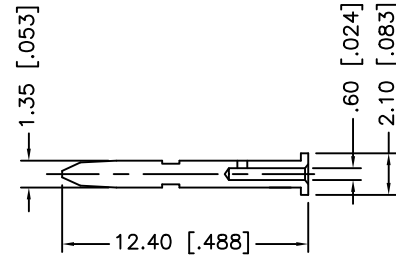
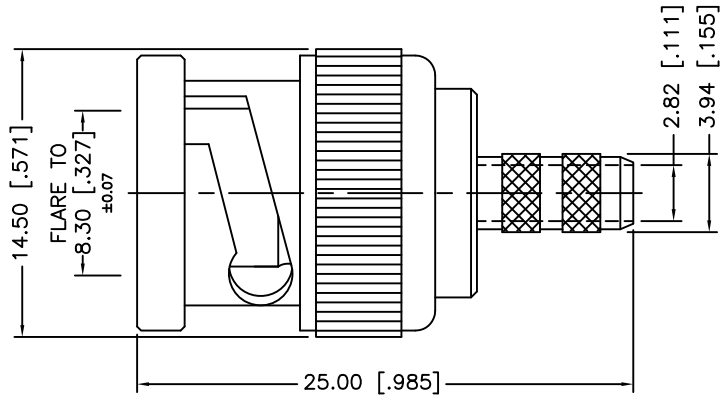

DESCRIPTION	MATERIAL	FINISH	QTY	
8				
7				
6				
5	FERRULE	BRASS	NICKEL	1
4	GASKET	RUBBER	RED	1
3	INSULATOR	TEFLON	NATURAL	1
2	CONTACT PIN	BRASS	GOLD	1
1	SHELL/BODY	BRASS	NICKEL	1

UNLESS OTHERWISE SPECIFIED DIMENSIONS ARE IN MILLIMETERS. DIMENSIONS IN [] ARE IN INCHES AND FOR CUSTOMER REFERENCE ONLY.

UNLESS OTHERWISE SPECIFIED TOLERANCES FOR MILLIMETERS ARE:
0.5 - 8mm ± 0.20mm
8 - 30mm ± 0.40mm
30 - 120mm ± 0.50mm

UNLESS OTHERWISE SPECIFIED TOLERANCES FOR INCHES ARE:
.020 - .315 = ± 0.007"
.315 - 1.180 = ± 0.015"
1.180 - 4.724 = ± 0.020"

DO NOT SCALE DRAWING

APPROVALS	DATE
DRAWN G.R.S.	07/19/07
CHECKED	
ISSUED	
SHEET 1 OF 1	
CAD FILE C:/112/112955.DWG	

Amphenol Connex

BNC CRIMP PLUG
(BELDEN 8218/VFM 809/1407B/1167B-75ohms)

PART NO. 112955

DWG. NO.	112955.DWG	REV.	B	SIZE	A	SCALE	NA
----------	------------	------	---	------	---	-------	----