

REV.	DATE	ECR NO.	DESCRIPTION
NC	10/15/04	-	INITIAL RELEASE
A	10/20/08	-	ADD LOCKWASHER AND NUT
B	03/16/09	-	REMOVE LOCKWASHER AND NUT

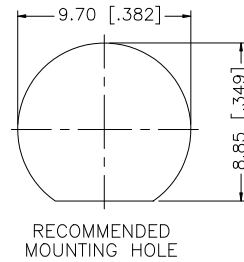
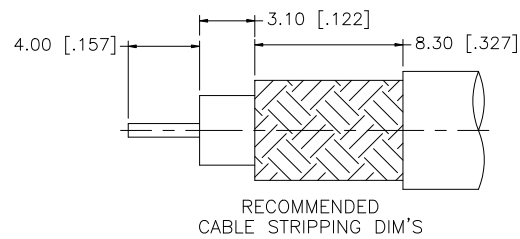
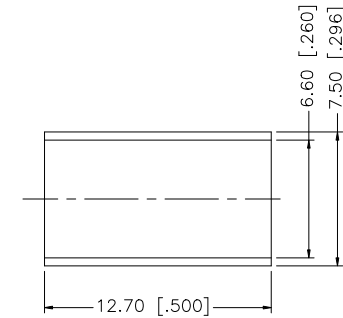
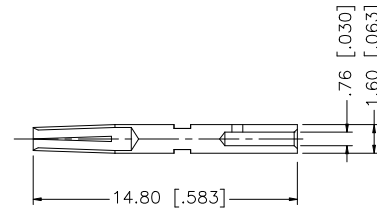
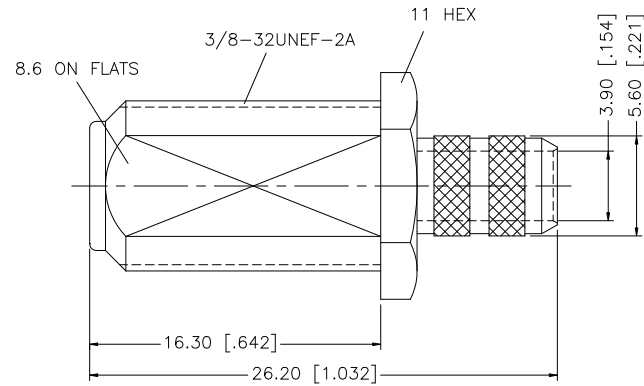

NOTES:

1. CRIMPED FERRULE HEX CRIMP SIZE .255" [6.48]
2. CONTACT PIN TO SOLDER

REV.	DATE	ECR NO.	DESCRIPTION
8			
7			
6	FERRULE	COPPER	NICKEL 1
5	HEX NUT	BRASS	NICKEL 1
4	LOCK WASHER	BRASS	NICKEL 1
3	CONTACT PIN	PHOS. BRONZE	GOLD 1
2	INSULATOR	PTFE	NATURAL 1
1	BODY	BRASS	NICKEL 1
	DESCRIPTION	MATERIAL	FINISH QTY

UNLESS OTHERWISE SPECIFIED DIMENSIONS ARE IN MILLIMETERS. DIMENSIONS IN [] ARE IN INCHES AND FOR CUSTOMER REFERENCE ONLY.		APPROVALS	DATE	<h1 style="color: blue; text-align: center;">Amphenol Connex</h1> <p style="text-align: center;">PART DESCRIPTION</p> <h2 style="text-align: center;">F CRIMP JACK (FOR BELDEN 8241, RG-59/U)</h2> <p style="text-align: center;">PART NO. 222158</p> <p style="text-align: center;">DWG. NO. 222158.DWG</p>
UNLESS OTHERWISE SPECIFIED TOLERANCES FOR MILLIMETERS ARE: 0.5 - 8mm ± 0.20mm 8 - 30mm ± 0.40mm 30 - 120mm ± 0.50mm		DRAWN GRS	03/16/09	
UNLESS OTHERWISE SPECIFIED TOLERANCES FOR INCHES ARE: .020 - .315 ± 0.007" .315 - 1.180 ± 0.015" 1.180 - 4.724 ± 0.020"		CHECKED		
DO NOT SCALE DRAWING		ISSUED		
		SHEET 1 OF 1		
		CAD FILE C:/222/222158.DWG		<p style="text-align: right;">REV. A SIZE A SCALE NA</p>