

REV.	DATE	ECR NO.	DESCRIPTION
NC	12/06/99	-	INITIAL RELEASE
A	01/13/00	-	ADD CABLE CALLOUT TO DESCRIPTION
B	09/26/05	-	UPDATE DRAWING FORMAT
C	02/20/09	-	REVISE CENTER CONTACT PIN LENGTH

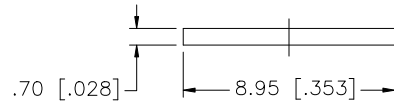
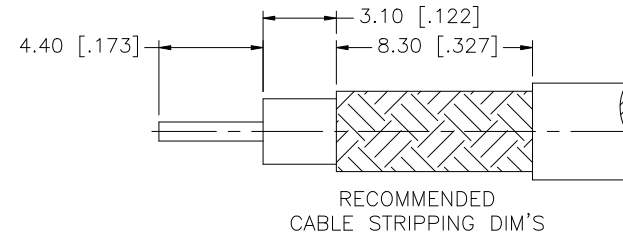
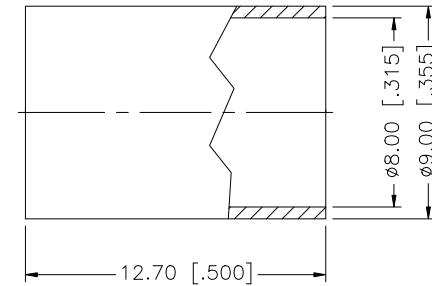
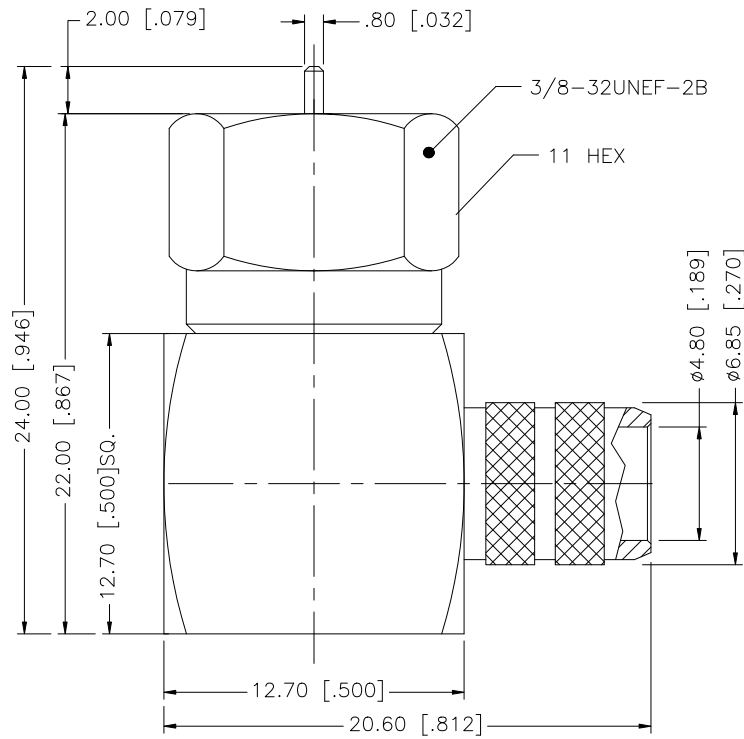

1. CRIMPED FERRULE HEX CRIMP SIZE .319" [8.10].

DESCRIPTION	MATERIAL	FINISH	QTY	DO NOT SCALE DRAWING	APPROVALS	DATE	PART DESCRIPTION							
8							<h1 style="text-align: center; color: blue;">Amphenol Connex</h1> <p style="text-align: center;">F R/A CRIMP PLUG (FOR RG-6/U CABLE)</p> <p style="text-align: center;">PART NO. 222164</p>							
7														
6	FERRULE	COPPER	NICKEL	1	DRAWN	GRS					02/22/09			
5	COVER	BRASS	NICKEL	1	CHECKED									
4	CONTACT PIN	BRASS	GOLD	1	ISSUED									
3	INSULATOR	PTFE	NATURAL	1	SHEET	1 OF 1								
2	BODY	BRASS	NICKEL	1										
1	HOUSING	BRASS	NICKEL	1										
					CAD FILE	C:/222/222164.DWG	DWG. NO.	222164.DWG	REV.	C	SIZE	A	SCALE	NA

UNLESS OTHERWISE SPECIFIED DIMENSIONS ARE IN MILLIMETERS. DIMENSIONS IN [] ARE IN INCHES AND FOR CUSTOMER REFERENCE ONLY.

UNLESS OTHERWISE SPECIFIED TOLERANCES FOR MILLIMETERS ARE:
0.5 - 8mm ± 0.20mm
8 - 30mm ± 0.40mm
30 - 120mm ± 0.50mm

UNLESS OTHERWISE SPECIFIED TOLERANCES FOR INCHES ARE:
.020 - .315 ± 0.007"
.315 - 1.180 ± 0.015"
1.180 - 4.724 ± 0.020"